

MoT Section	1200	TAC Section	Not Applicable
-------------	------	-------------	----------------

1200 CONTRACTS AND DRAWINGS CHAPTER

TABLE OF CONTENTS

1200 CONTRACTS AND DRAWINGS CHAPTER 1200-1

TABLE OF CONTENTS 1200-1

1210 GENERAL PROCEDURES 1210-1

1210.01 INTRODUCTION 1210-1

1210.02 GENERAL 1210-1

1210.03 DATA STORAGE 1210-1

1210.04 NUMBERING OF DRAWINGS 1210-1

1210.05 SIGNING OF DRAWINGS 1210-2

1210.06 AMENDED DRAWINGS 1210-3

FIGURE 1210.A TITLE BLOCK FOR MAJOR PROJECTS KEY PLAN 1210-4

FIGURE 1210.B TITLE BLOCK FOR REGION/DISTRICT KEY PLAN 1210-5

FIGURE 1210.C TITLE BLOCK FOR DRAWINGS 1210-6

1220 CONTRACT DRAWINGS 1220-1

1220.01 FRONT PAGE 1220-1

1220.02 KEY PLAN 1220-1

1220.03 LEGEND 1220-2

1220.04 PLAN PLATES 1220-2

1220.05 PROFILES 1220-3

1220.06 TYPICAL SECTIONS 1220-4

1220.07 GEOMETRICS AND LANING 1220-4

1220.08 SPOT ELEVATIONS 1220-5

1220.09 SIGNING AND PAVEMENT MARKINGS 1220-6

1220.10 DRAINAGE AND/OR UTILITIES 1220-6

1220.11 PROPERTY ACQUISITION PLANS 1220-7

1220.12 VOLUME OVERHAUL DIAGRAM 1220-11

1220.13 GRAVEL QUANTITY AND HAUL CHARTS 1220-12

FIGURE 1220.A SAMPLE FRONT PAGE 1220-13

FIGURE 1220.B SAMPLE KEY PLAN 1220-14

FIGURE 1220.C SAMPLE LEGEND 1220-15

FIGURE 1220.D SAMPLE PLAN 1220-16

FIGURE 1220.E SAMPLE PROFILE 1220-17

MoT Section	1200	TAC Section	Not Applicable
-------------	------	-------------	----------------

FIGURE 1220.F	SAMPLE TYPICAL SECTIONS.....	1220-18
FIGURE 1220.G	SAMPLE TYPICAL SECTIONS.....	1220-19
FIGURE 1220.H	SAMPLE GEOMETRICS AND LANING	1220-20
FIGURE 1220.I	SAMPLE GEOMETRICS AND LANING	1220-21
FIGURE 1220.J	SAMPLE SPOT ELEVATIONS.....	1220-22
FIGURE 1220.K	SAMPLE SIGNING AND PAVEMENT MARKINGS	1220-23
FIGURE 1220.L	SAMPLE DRAINAGE	1220-24
FIGURE 1220.M	SAMPLE PROPERTY ACQUISITION PLAN (RURAL)	1220-25
FIGURE 1220.N	SAMPLE PROPERTY ACQUISITION PLAN (URBAN)	1220-26
FIGURE 1220.O	SAMPLE OVERHAUL TABULATION CHART	1220-27
FIGURE 1220.P	SAMPLE VOLUME OVERHAUL.....	1220-28
FIGURE 1220.Q	SAMPLE VOLUME OVERHAUL.....	1220-29
FIGURE 1220.R	SAMPLE GRAVEL QUANTITIES AND HAUL.....	1220-30

1230 AUTOCAD LAYERS..... 1230-1

1230.01	REVISED STANDARDS	1230-1
1230.02	NCS LAYER STANDARD	1230-1
1230.03	LAYER TABLE PROPERTIES.....	1230-2
1230.04	LAYER LIST	1230-5

1240 AUTOCAD STANDARDS..... 1240-1

1240.01	INTRODUCTION	1240-1
1240.02	REQUIRED FILES	1240-1
1240.03	BYLAYER PROPERTIES.....	1240-1
1240.04	TEXT STYLES.....	1240-2
1240.05	TEXT SCALING AND STANDARD HEIGHTS	1240-2
1240.06	GENERAL ANNOTATION – TEXT HEIGHTS	1240-3
1240.07	EXISTING PLAN DETAIL – TEXT HEIGHTS	1240-3
1240.08	PROPOSED PLAN DETAIL – TEXT HEIGHTS	1240-4
1240.09	TYPICAL CROSS SECTIONS – TEXT HEIGHTS	1240-5
1240.10	CROSS SECTIONS – TEXT HEIGHTS	1240-5
1240.11	PROFILES – TEXT HEIGHTS.....	1240-5
1240.12	PLOT STYLES	1240-6
1240.13	SCREENING EXISTING DETAIL.....	1240-8

MoT Section	1200		TAC Section	Not Applicable
-------------	------	--	-------------	----------------

1250 AUTOCAD SYMBOLS 1250-1

1250.01	INTRODUCTION	1250-1
1250.02	SURVEY SYMBOLS	1250-2
1250.03	AERIAL UTILITIES	1250-4
1250.04	DETAIL	1250-5
1250.05	DRAINAGE	1250-6
1250.06	PROPOSED DRAINAGE.....	1250-8
1250.07	UNDERGROUND	1250-9
1250.08	ELECTRICAL.....	1250-10
1250.09	METERS	1250-11
1250.10	ROAD SIGNS	1250-12
1250.11	LANE ARROWS.....	1250-13
1250.12	MISCELLANEOUS ARROWS	1250-13
1250.13	ROUNDBOUT LANE ARROWS.....	1250-14
1250.14	CONSTRUCTION NOTES.....	1250-16
1250.15	MISCELLANEOUS NOTES	1250-17
1250.16	GEOTECH LEGENDS	1250-19
1250.17	GEOTECH GENERAL	1250-22
1250.18	GEOTECH PIT DEVELOPMENT	1250-23
1250.19	TITLEBLOCKS AND FRAMES.....	1250-25

1260 AUTOCAD LINETYPES 1260-1

1260.01	LINETYPE STANDARDS.....	1260-1
1260.02	ALIGNMENT AND BARRIER LINETYPES.....	1260-2
1260.03	CONSTRUCTION AND EXISTING FEATURES LINETYPES	1260-3
1260.04	UNDERGROUND AND GEOTECH LINETYPES	1260-4
1260.05	HYDROLOGY, LOT BOUNDARY AND TOE LINETYPES.....	1260-5
1260.06	TOPOGRAPHY AND WALL LINETYPES.....	1260-6
1260.07	CONTOUR INTERVALS	1260-7
1260.08	LINETYPE PATTERN DIMENSIONS	1260-8

MoT Section	1200		TAC Section	Not Applicable
-------------	------	--	-------------	----------------

1270	CAICE DESIGN PROJECT DATA FORMAT POLICY: TERMS OF REFERENCE	1270-1
1270.01	GENERAL	1270-2
1270.02	CAICE DESIGN PROJECT DATA FORMAT POLICY: EXCEPTIONS	1270-3
1270.03	CAICE DESIGN PROJECT DATA ARCHIVE: MISSING OR PROBLEM CONTENT	1270-5
1270.04	MINISTRY STANDARD LIBRARIES, TABLES, MACROS, FRAGMENTS	1270-5
1270.05	DESIGN PROJECT: FOLDERS AND ORGANIZATION	1270-6
1270.06	DESIGN PROJECT DATA ARCHIVE: PROJECT LOG FILES	1270-10
1270.07	DESIGN PROJECT DATA ARCHIVE: CDG FILES	1270-13
1270.08	DESIGN PROJECT DATA ARCHIVE: CONTENT AND NAMING CONVENTIONS	1270-15
1270.09	ZONE DESIGNATIONS	1270-64
1270.10	DESIGN PROJECT DATA ARCHIVE: PREPARATION	1270-66
1270.11	CONTRACT DRAWINGS	1270-68
1270.12	CONTRACT MATERIAL VOLUMES	1270-68
1270.13	DESIGN PROJECT ELECTRONIC DELIVERABLES: QUALITY CHECKLIST	1270-69

MoT Section	1210	TAC Section	Not Applicable
-------------	------	-------------	----------------

1210 GENERAL PROCEDURES

1210.01 INTRODUCTION

The preferred computer drafting program to be used by contractors for production of contract drawings for the Ministry of Transportation and Infrastructure is **AutoCAD**® by Autodesk®, Inc.

A minimum of one hard copy of the contract drawings will be supplied along with a Compact Disc or DVD containing a digital copy of all drawing files and referenced files required to fully view, edit and print the drawings.

The only acceptable drawing file formats are the **AutoCAD DWG/DXF** formats. Manually drafted drawings will no longer be produced for contracts.

AutoCAD is used by all ministry branches, regions and districts to facilitate:

- a. The development and maintenance of standards to ensure consistent drawing quality and integrity.
- b. The transfer of technical information within the ministry in a manner that simplifies and standardizes the manipulation of technical information by each branch.
- c. The development and maintenance of a record system to ensure accessibility and continuity.
- d. Interaction with other electronic geo-based systems (GIS, CAICE, etc.).

1210.02 GENERAL

AutoCAD provides the ability to draw in real world coordinates using real units of measure. Because of the linear nature of highway design, units must be carefully considered. All design drawings should be constructed with the metre as the drafting unit.

If possible, the entire project should be designed and drawn as a single “design drawing”. This drawing will contain all the necessary information required for each plan plate. Refer to [Section 1220.04](#). Working frames are then superimposed, overlapped and orientated to indicate the individual plan plates. At this point a great part of the drawing can be saved, with the appropriate name, as the key plan.

The usage of a single design drawing will promote consistency in the symbols, linetypes, colors, plot styles, layering, etc. in the project.

Each working frame becomes a viewport for the paper space layout for individual drawings. These layouts are used for final plotting of contract drawings and should be created without destroying or subdividing the larger design drawing.

1210.03 DATA STORAGE

File Names

Recommended file names use the region number and drawing sequence (assigned by the ministry) in addition to the drawing type (e.g. R1-185-100 for plans).

Archive

When the contract drawings are finalized and plotted for signature, the plot versions (e.g. PDF) of the drawings shall be archived to CD or DVD (two sets). Both sets of the archive make up part of the contract and are property of the ministry. Project discs are labelled as follows:

Drawing Series Number (see section below)

Project Name:	Start Rd to End Creek
Consultant:	ABC Engineering
Disc Number:	x of y
Date	YYYY-MM-DD

In house designs will refer to the ministry designer in place of the consultant company name.

Ministry Designer: W. Smith

1210.04 NUMBERING OF DRAWINGS

Refer to Technical Circular T-5/93.

When a contract is issued for design, the drawings are assigned a designation number by the Regional Manager of Engineering, or their designate.

The designation number is made up of the region number or name and a drawing series number.

Note that the title page is never numbered.

MoT Section	1210	TAC Section	Not Applicable
-------------	------	-------------	----------------

The complete format is as follows:

RR-NNN-*nnn*

Where RR is the region encompassing all or most of the project, NNN is the drawing series within that region and *nnn* is the sheet number within that series.

Example: R1-127-001

R1-127 is unique to the project and indicates Region 1 and drawing series 127. 001 indicates drawing #1 in this series. 001 is usually the key plan.

At present there are three regional designations: R1, R2, and NR. NR stands for Northern Region and is used in place of R3 to avoid duplicating previously used contract drawing numbers for another area of the province designated R3 prior to 2002.

Drawings sheets are numbered sequentially or in sequential groups throughout the project and are arranged in the general order as shown on the index. Depending on the type and complexity of the contract, some of these items may be combined or omitted entirely.

Traditional Sequential Method

Drawing numbers are sequential, leading zeros are omitted.

RR-NNN-1	Key Plan
RR-NNN-2 to 14	Plans
RR-NNN-15 to 25	Profiles
and so on...	

Sequential by Drawing Type Method

The sheet numbers may be grouped by drawing type. This allows drawings to be added or deleted without the need to re-sequence the entire project. The following sheet numbering system is suggested:

RR-NNN-001	Key Plan
RR-NNN-101 to 199	Plans
RR-NNN-201 to 299	Profiles
RR-NNN-301 to 399	Typical Sections
RR-NNN-401 to 499	Geometrics & Laning
and so on...	

1210.05 SIGNING OF DRAWINGS

Technical Circular T-2/93 has been replaced by the following procedure.

Title Blocks

Title blocks are limited to working drawings and will show only one signature block for the Senior Designer. This will be a consultant's representative or the Regional Manager of Design whether for major projects, regional, or district contracts.

Contract drawings prepared by ministry staff or by consultants selected from the professional category of RISP shall be signed and stamped by a professional engineer (APEGBC). Additional drawing types requiring a professional engineer as the senior designer will be determined as needed. Professional engineers must sign and stamp in the signature block provided. Refer to [Figure 1210.C](#).

All contracts, 3 km or longer, will have a front page and a key plan page. The front page will have no title block and it will show the provincial logo, the ministry name, the project name and number and the name and title of the Regional Director or Chief Engineer (no signature).

The key plan page will show the ministry name, a location map, a key plan, the drawing index, the symbol legend (as appropriate), the contract details including contract type, number, location, length, etc. as well as the dated signatures of the Regional Director and Regional Manager of Engineering.

Infrequently, the key plan may be signed by the HQ Branch Director and the Chief Engineer.

For major projects, the Major Project Director will sign along with the Project Manager.

The key plan page signatures will be on either the full size or reduced title block as shown on [Figure 1210.A](#) or [Figure 1210.B](#).

For small contracts less than 3 km, the front page is not mandatory.

The signatures on the key plan signify acceptance for construction. The senior designer signs and stamps the working drawings, assuring accuracy and content. These signatures are required for all projects regardless of length or size.

MoT Section	1210	TAC Section	Not Applicable
-------------	------	-------------	----------------

Digital Signatures

For electronic drawings, Engineers of Record are to use the digital signature and electronic sealing technology approved by the Association of Professional Engineers and Geoscientists of BC.

More information can be found at the APEGBC site: www.apeg.bc.ca/ppractice/digitalsignature.html.

Use of the digital signature and electronic sealing is expected to be made mandatory at a future date pending further discussion with the Consulting Engineers of BC.

Until digital signatures become mandatory, it will still be acceptable to submit drawings that are hand stamped and signed.

Property Acquisition Plan (PAP)

Property acquisition plans shall be signed by the senior designer which indicates the only meaningful review to ensure the accuracy of the proposed right-of-way.

Exception: PAP drawings for small trespasses and drainage easements on unnumbered routes and Section 42 acquisitions may be signed by the District Manager, Transportation.

Quality Control

The Design Manager for the project will, at the start of each major design phase, identify the person who will provide quality control of the technical content by reviewing and approving each stage.

Issuing of Drawings for Tender

Refer also to Technical Circular T-11/06

One complete set of full size drawings, signed and stamped by the senior designer (consultant engineer or ministry engineer), with the appropriate ministry officials signatures on the key plan, may be sent to the Queen's Printer. These drawings will be scanned to produce the electronic PDF files for posting on the BC Bid website.

Queen's Printer will print the full-size and half-size drawings for distribution to courtesy plan holders and for tender document sales. Local printers may also be used to produce the electronic PDF files and contract administration offices would then post them on the BC Bid website and make them available to Queen's Printer for printing.

As per the policy in the Contract Administration Manual, the signed and stamped tender drawings will be used for the contract award. Therefore, these drawings shall **not** be annotated as "Issued for Tender" or "Issued for Construction".

For scanning and copying purposes, ink stamps must be used. Embossed seals are not acceptable.

Engineering drawings issued for tender, that have not been signed and sealed, must be authorized for use by the Regional Director or Branch Director and the drawings must be labelled "Preliminary Not for Construction" prior to posting on the BC Bid website.

1210.06 AMENDED DRAWINGS

1. Once a project drawing has been approved by either the Regional Director or the Chief Engineer, any further alterations or amendments must be recorded in the revision space provided. Revised drawings must be signed and stamped by the Senior Designer.
2. A major revision which completely alters the intent of the original approved drawing must be re-approved. (i.e. signatures of the Senior Designer, Regional Manager of Engineering and Regional Director).
3. If an approved project plan is amended, either the original or seven prints are to be submitted to the Regional Property Agent.
4. When a project plan drawing is amended to show R/W as purchased, do not remove the original boundary or area. Show the amended R/W boundary with a heavier line and note the increase or decrease in area.

MoT Section	1210	TAC Section	Not Applicable
-------------	------	-------------	----------------

FIGURE 1210.A TITLE BLOCK FOR MAJOR PROJECTS KEY PLAN

		MINISTRY OF TRANSPORTATION AND INFRASTRUCTURE NOTE 1 NOTE 1		REGION OR DISTRICT MAP	
NOTE 2					
PROJECT MANAGER DATE YYYY-MM-DD NOTE 5	PROJECT DIRECTOR DATE YYYY-MM-DD REG R1 NOTE 6	PROJECT NUMBER DRAWING NUMBER NOTE 7	REV A		

FULL SIZE TITLE BLOCK

NOTE 3 PROJECT MANAGER DATE YYYY-MM-DD	NOTE 4 PROJECT DIRECTOR DATE YYYY-MM-DD
--	---

(signature boxes are centred at the bottom of the sheet)

(standard lower right location) DRAWING NUMBER NOTE 7	REV A
---	----------

REDUCED VERSION OF TITLE BLOCK (ALTERNATE)

NOTES:

1. MAJOR PROJECT NAME
2. SUB-PROJECT / DESCRIPTIVE NAME AND SPECIFIC DRAWING INFORMATION
The sub-project / descriptive name must be listed on all drawings and all correspondence
3. PROJECT MANAGER'S SIGNATURE
The project manager signs for acceptance of the design work on behalf of the ministry
4. PROJECT DIRECTOR'S SIGNATURE
The project director signs to authorize the use of the design work for the major project
5. THE MINISTRY OR CONSULTANT CORRESPONDENCE FILE NUMBER
The heading should be changed to identify ownership of the file number
Examples: MINISTRY FILE NUMBER, CONSULTANT FILE NUMBER
6. PROJECT NUMBER
7. PROJECT DRAWING NUMBERS USED FOR DRAWING CONTROL AND TRACKING

THE FULL SIZE TITLE BLOCK IS NORMALLY USED. THE REDUCED VERSION IS AN ALTERNATIVE. SEE SAMPLE DRAWINGS.

MoT Section	1210	TAC Section	Not Applicable
-------------	------	-------------	----------------

FIGURE 1210.B TITLE BLOCK FOR REGION/DISTRICT KEY PLAN

 BRITISH COLUMBIA		MINISTRY OF TRANSPORTATION AND INFRASTRUCTURE NOTE 1 NOTE 1		REGION OR DISTRICT MAP	
NOTE 2					
REGIONAL MANAGER, ENGINEERING DATE YYYY-MM-DD	REGIONAL DIRECTOR DATE YYYY-MM-DD	PROJECT NUMBER NOTE 6	REG R1	DRAWING NUMBER NOTE 7	REV A
FILE NUMBER NOTE 5					

FULL SIZE TITLE BLOCK

NOTE 3 REGIONAL MANAGER, ENGINEERING DATE YYYY-MM-DD	NOTE 4 REGIONAL DIRECTOR DATE YYYY-MM-DD
--	--

(signature boxes are centred at the bottom of the sheet)

(standard lower right location) DRAWING NUMBER NOTE 7	REV A
---	----------

REDUCED VERSION OF TITLE BLOCK (ALTERNATE)



NOTES:

1. REGION OR DISTRICT NAME
2. PROJECT NAME AND SPECIFIC DRAWING INFORMATION
The project name must be listed on all drawings and all correspondence
3. REGIONAL MANAGER OF ENGINEERING'S SIGNATURE
4. REGIONAL DIRECTOR'S SIGNATURE
5. THE REGION, DISTRICT OR CONSULTANT CORRESPONDENCE FILE NUMBER
The heading should be changed to identify ownership of the file number
Examples: DISTRICT FILE NUMBER, CONSULTANT FILE NUMBER
6. PROJECT NUMBER
7. PROJECT DRAWING NUMBERS USED FOR DRAWING CONTROL AND TRACKING

THE FULL SIZE TITLE BLOCK IS NORMALLY USED. THE REDUCED VERSION IS AN ALTERNATIVE. SEE SAMPLE DRAWINGS.

MoT Section	1210	TAC Section	Not Applicable
-------------	------	-------------	----------------

FIGURE 1210.C TITLE BLOCK FOR DRAWINGS

 BRITISH COLUMBIA		MINISTRY OF TRANSPORTATION AND INFRASTRUCTURE NOTE 1 NOTE 1		REGION OR DISTRICT MAP
NOTE 2				
NOTE 7 SCALE 0 0.5 1:50 2.5m 		NOTE 3 & 8 		
CAD FILENAME _____ CAD FILENAME _____ DATE _____ YYYY-MM-DD DATE _____ 2010-03-31		DESIGNED _____ NOTE 9 DATE _____ 2010-03-31 QUALITY CONTROL _____ BOB JOHNSON DATE _____ 2010-03-31 QUALITY ASSURANCE _____ JOHN SMITH DATE _____ 2010-03-31 DRAWN _____ C WILLIAMSON DATE _____ 2010-03-31		
SENIOR DESIGNER DATE _____ YYYY-MM-DD		PROJECT NUMBER NOTE 5		
REVISIONS NOTE 10		REG R1		
REV DATE NOTE 9		DRAWING NUMBER NOTE 6		
FILE NUMBER NOTE 4		REV A		

NOTES:

1. REGION, DISTRICT, BRANCH OR MAJOR PROJECT NAME
2. PROJECT NAME AND SPECIFIC DRAWING INFORMATION
The project name must be listed on all drawings and all correspondence
3. SENIOR DESIGNER'S SIGNATURE AND STAMP GOES HERE
The senior designer may be a consultant, the Regional Manager of Design or the headquarters equivalent
The SENIOR DESIGNER label may be replaced with the title of the signee
4. THE HEADQUARTERS, REGION, DISTRICT OR CONSULTANT CORRESPONDENCE FILE NUMBER
The heading should be changed to identify ownership of the file number
Examples: DISTRICT FILE NUMBER, CONSULTANT FILE NUMBER
5. PROJECT NUMBER
6. PROJECT DRAWING NUMBERS USED FOR DRAWING CONTROL AND TRACKING
7. CONSULTANT AND PARTNER LOGOS MAY BE ADDED HERE
8. REVISIONS MUST BE SIGNED AND STAMPED BY THE SENIOR DESIGNER
9. PERSON'S FIRST INITIAL (minimum) AND COMPLETE LAST NAME
10. "ISSUED FOR TENDER" OR "ISSUED FOR CONSTRUCTION" SHALL NOT BE ANNOTATED ON ANY TENDER DRAWINGS

MoT Section	1220	TAC Section	Not Applicable
-------------	------	-------------	----------------

1220 CONTRACT DRAWINGS

1220.01 FRONT PAGE

Sample Figure 1220.A

This page will have the provincial logo, ministry name, project number, project name and will indicate the name and title of the Chief Engineer or the Regional Director (no signatures).

Large projects (discretionary ≥ 3 km) will have a separate front page, not numbered, with the name and title of the Chief Engineer or Regional Director (no signature). For smaller projects (discretionary) there is no requirement for a front page.

1220.02 KEY PLAN

Sample Figure 1220.B

The designer has the option of using the full size title block or the reduced version. See Figures 1210.A and 1210.B. In the reduced version, the Drawing Number and Revision remain at the lower right and the signatures are moved to the center.

Key Plan Page Contents

This page shall contain the following information, appropriate to the scope and scale of the project.

1. A large scale location map showing:
 - Highway route(s) and city/town name(s)
 - Location of project
 - North arrow (preferably oriented upwards)
2. A key plan schematic drawing showing:
 - North arrow oriented to the location map
 - Scale
 - Sufficient cadastral mapping for orientation
 - City/town boundaries for reference, land districts, ranges, section lines, street names
 - Borders depicting mapping sheet coverage and layout
 - The proposed design location line for the main line with the beginning and end stations labelled LIMIT OF CONSTRUCTION
 - The proposed design L-lines for any frontage or service roads with their appropriate LOC stations (if applicable)

3. A legend (if it is a small enough project) showing standard symbols/linetypes representing components on the drawings. Sections 1250 and 1260 show the detailed definitions. Legend symbols and linetypes shall be scaled at 1:1.
4. Survey information may be shown as specified in the General Survey Guide (600.02). Examples:
 - Survey control points table
 - Survey control origin
 - Data sources and quality
5. A title showing:

PROVINCE OF BRITISH COLUMBIA
 MINISTRY NAME
 PROJECT NUMBER
 HIGHWAY NAME & NUMBER - GENERAL LOCATION
 PROJECT NAME
 CONTRACT TYPE
 PROJECT LIMITS
 STA. X+XX.XXX - STA. X+XX.XXX
 LKI: SEG. XXXX
 km XXXX TO km XXXX

Contract types are paving, grading, etc. Project limits are defined by road names, chainage, etc. See sample drawing for exact format.

6. An index showing the following (as applicable):

RN-nnn-001	Key Plan
RN-nnn-002	Legend
RN-nnn-101 to 1xx	Plans
RN-nnn-201 to 2xx	Profiles
RN-nnn-301 to 3xx	Typical Sections
RN-nnn-401 to 4xx	Geometrics and Laning
RN-nnn-501 to 5xx	Spot Elevations
RN-nnn-601 to 6xx	Signing & Pavement Markings
RN-nnn-701 to 7xx	Drainage
RN-nnn-801 to 8xx	Volume Overhaul Diagram
RN-nnn-901 to 9xx	Gravel Quantity and Haul Chart

various numbering All other drawings (*)

* Bridge, Geotechnical, Electrical & Lighting, etc.

The key plan is signed by the Regional Manager of Engineering and Regional Director or by a headquarters Branch Director and the Chief Engineer. These signatures indicate acceptance for construction. (Refer to [Section 1210.05](#))

MoT Section	1220		TAC Section	Not Applicable
-------------	------	--	-------------	----------------

1220.03 LEGEND

Sample Figure 1220.C

Large projects may have one page exclusively for the legend. All symbols, linetypes and any other unique features are listed on this page. Include a standard title block as shown in the sample figure.

1220.04 PLAN PLATES

Sample Figure 1220.D

Project chainage will run left to right with the north arrow pointing up. If a compromise is required, the North arrow orientation may be altered.

The plan drawing series shall be cross referenced to any required geometrics and laning, drainage, utility, spot elevation and profile series drawings. All cross reference boxes shall be in a clear area of the drawing and should generally conform to the sample drawing layout.

Plan Plates Information

Base Information (Screened or Masked)

AutoCAD methods for screening and masking are discussed in [Section 1240.13](#).

- Mapping at a scale appropriate to the type of work: 1:250, 1:500 and 1:1000 are the standards. See [Section 1260.07](#) for contour interval standards.
- Accurate representation of all existing buildings, utilities (aerial and underground), accesses, drainage structures and courses, fences, road surfaces and shoulders.
- Current legal descriptions and lot lines for all plans, easements, etc. within the project – also city/town boundaries, land district, ranges, sections and district lots, Indian Reserves, parks, railways, etc.

All are shown with their standard symbols and linetypes (refer to Sections [1250](#) and [1260](#)).

All field information that represents BCLS data should be shown in accordance with symbols and abbreviations which have been approved by the Surveyor General (see [Section 1250.02](#)).

Title Blocks Surveyed by:
 Survey date:
 Office processed by:

Refer to Section 600.04, General Survey Guide.

All Relevant P-Line Information

- Identification: i.e. "P100", PIs, POTs and stations
- Bearings between PIs or POTs
- Ties between P-line PIs or POTs and cadastral survey points (i.e., iron pins or monuments) showing bearings and distances

Design L-Line Information

- The glossary of terms in the Major Works Construction Agreement, defines the LIMIT OF CONSTRUCTION as the geographic limits of the project. The beginning and end of a project plus the extent of all sides shall be so called.
- Limits of construction on the primary L-line with stations
- Limits of construction on the secondary L-line with stations
- Numerical identification placed close to all L-lines, eg. 'L500'
- Labelling of all horizontal control stations, ex:

PI or L100A1-PI	Point of Intersection
POT	Point on Tangent
POC	Point on Curve
POS	Point on Spiral
BC	Beginning of Curve
EC	End of Curve
TS	Tangent to Spiral
SC	Spiral to Curve
PCC	Point of Compound Curvature
CC	Curve to Curve
CS	Curve to Spiral
SS	Spiral to Spiral
ST	Spiral to Tangent
STS	Spiral Tangent Spiral
SCS	Spiral Curve Spiral

- Identification of any intersecting L-lines thus:
POT 124+12.571 =
POT 505+00.000
 (the ####+####.#### format is also acceptable)

MoT Section	1220	TAC Section	Not Applicable
-------------	------	-------------	----------------

- Label stations that define structures, i.e., bridge abutment stations.
- Station ticks at 20 m intervals, annotated at 100 m intervals
- Azimuth indicated on tangents only on P-lines and L-lines, shown thus: 00°00'00"

Horizontal curve data shall be shown opposite the PI and internal to the curve where possible.

Horizontal Curve Data for Simple Curves

R	Radius of curve (with direction *)
Δ	Delta (intersection) angle
AD	Tangential distance (PI to BC or EC)
ARC	Arc length of curve
Ec	External distance (PI to curve)

Horizontal Curve Data for Spiralled Curves

R	Radius of curve (with direction *)
Δ	Delta angle of the entire curve incl. spirals
Δ_c	Delta angle of the circular curve portion
AD	Tangential distance (PI to TS/ST **)
ARC	Arc length of circular curve (SC to CS)
Es	External distance (PI to curve)

* Curve direction shown with an "LT" or "RT" suffix

** Unequal spirals show AD_1 and AD_2 (PI-TS/PI-ST)

The spiral information shall be shown internal to the spiral between the (TS/SC and CS/ST) thus:

Ls	Length of spiral
θ_s	Spiral angle

Compound curve data location is at the discretion of the designer as long as the information is complete.

Compound curve data is separated into two blocks: R_1 , Δ , Δ_{c1} , AD_1 , ARC_1 and R_2 , Δ_{c2} , AD_2 , ARC_2 .

Include the PI station with the curve data in complex designs with numerous alignments/curves.

Other

The following elements shall be shown on the plan drawings to fully indicate the impact of the design:

- Geotechnical test holes (if available)
- The proposed edge of pavement drawn with a 0.50mm pen and clearly labelled

- Top of Cut (TOC) and Base of Fill (BOF) drawn with the standard line patterns; their transition point shall be labelled C/F or F/C
- Removals of existing infrastructure shall be clearly labelled. This includes all utilities such as hydro, gas, water, telephone and sewer, as well as curbs, barrier, pavement, sidewalks, drainage structures, and services such as underground storage tanks. When an existing fence is affected, clearly label the start and end of the affected section(s) as well as the type of fence.

R/W requirements for the project shall be laid out on a separate set of Property Acquisition Plans. These drawings shall have the same number as their plan counterpart but with an "RW" suffix.

The only exception to the requirement for separate R/W plans will be for small projects (1-2 plan sheets) and only with approval from the Regional Properties Branch (see [Section 1220.11](#)).

Clearing and grubbing areas shall be listed to four decimal places, indicated on the plan sheets only, and summarized in a boxed note as "CL. and GR. total this sheet x.xxxx ha". Individual areas shall also be outlined in a box.

Clearing and grubbing limits, if not coincidental with the R/W, shall be shown with the standard line pattern, annotated as "Clearing and Grubbing Limit" (or "Cl & Gr" if space is limited). These boundaries shall be established following the same criteria as the R/W boundary (see [Section 1220.11](#)).

Signing and pavement markings shall be indicated on a separate set of drawings.

A schematic layout of the plan sheets shall be shown on each drawing with the specific sheet highlighted to show its position in the project.

1220.05 PROFILES

Sample [Figure 1220.E](#)

Profiles shall be developed for all L-line traverses in a manner that portrays vertical as well as horizontal alignments.

All L-line profiles shall be at 1:2000/1:200 H/V. An appropriate scale for a secondary/frontage road could be 1:1000/1:100 H/V. Multiple profiles may be drawn on a sheet as long as they remain

MoT Section	1220	TAC Section	Not Applicable
-------------	------	-------------	----------------

individual entities. **Urban Design** profile scale is 1:250/1:50 H/V.

The K value shall be entered on all profiles for each curve. Asymmetrical vertical curves shall indicate the K value for each half plus the applicable lengths of vertical curve: VC (total), VC1 and VC2.

Design speed of the proposed road shall be shown on the profile in a boxed note. In the case of multiple zones, the note must include a starting station. Multiple design profiles will have individual design speed notations.

Existing utility crossings, new culvert crossings, benchmarks, drainage, construction notes, quantities and etcetera are also included.

Project quantities shall be shown across the top of the profile. Items shown are project specific, some examples are: excavation, embankment, stripping, SGSB depth, hog fuel depth, side slopes, etc.

Profiles that run parallel to, or cross the main L-line, shall be referenced to the main line in order to easily locate their position on the plan sheets.

The horizontal alignment shall be shown symbolically and TO SCALE on the bottom of the profile. Azimuths will be shown for all tangent sections. Curves will be shown as offset straight lines. Spirals are sloped lines between tangent and curve. Station of transition points (BC/EC or TS/SC, CS/ST) shall be shown, as well as the radius, with direction (LT or RT), design curve maximum super elevation and a separate diagram showing left/right super elevation values at key transition points.

1220.06 TYPICAL SECTIONS

Sample Figures 1220.F and 1220.G

The typical section drawing(s) shall show all aspects of the template criteria relating to all the road classifications within the project. Most of this information is currently defined within Section 430, 440 and 450. However, as a result of site specific anomalies, approved variations to the standard are occasionally warranted.

The sections shall be developed at a scale that allows the viewer to assimilate the data without question. If a section is too long to be shown in its entirety, it should be broken rather than drawn 'not

to scale'. If there are variable scales involved on a sheet, bar scales shall be shown near each section and 'as shown' shall be labelled in the scale box.

The designer should not place template section information on other drawings. It is more effective to cross reference to a drawing specifically designated for the purpose.

Every effort should be made to maintain continuity of information. For example, enlarged detail should be shown relative to its main section.

1220.07 GEOMETRICS AND LANING

Sample Figure 1220.H and 1220.I

Geometrics and laning drawings shall include a north arrow and grid points correctly aligned, with sufficient latitude (northing) & departure (easting) labels for orientation.

Required Design L-line Information

- Secondary L-line LIMIT OF CONSTRUCTION with stations
- Numerical labels near all L-lines, i.e. 'L500'
- Street names
- Labelling of all horiz. control stations, such as:

PI or L100A1-PI	Point of Intersection
POT	Point on Tangent
POC	Point on Curve
POS	Point on Spiral
BC	Beginning of Curve
EC	End of Curve
TS	Tangent to Spiral
SC	Spiral to Curve
PCC	Point of Compound Curvature
CC	Curve to Curve
CS	Curve to Spiral
SS	Spiral to Spiral
ST	Spiral to Tangent
STS	Spiral Tangent Spiral
SCS	Spiral Curve Spiral
- Identification of any intersecting L-lines thus:

POT 124+12.571 =
POT 505+00.000
(the ####+###.### format is also acceptable)

MoT Section	1220	TAC Section	Not Applicable
-------------	------	-------------	----------------

- Label stations that define structures, i.e. bridge abutments stations
- Station ticks at 20 m intervals, annotated at 100m intervals
- Coordinates for: limits of construction, PI's and L-line intersections

Horizontal curve data shall be shown opposite the PI and internal to the curve where possible.

Horizontal Curve Data for Simple Curves

R	Radius of curvature (with direction *)
Δ	Delta (intersection) angle
AD	Tangential distance (PI to BC or EC)
ARC	Arc length of curve
Ec	External distance (PI to curve)

The horizontal curve information for frontage bulbs and intersections shall be referenced and tabled as shown in sample [Figure 1220.I](#)

Horizontal Curve Data for Spiralled Curves

R	Radius of curvature (with direction *)
Δ	Delta angle of the entire curve incl. spirals
Δ_c	Delta angle of the circular curve portion
AD	Tangential distance (PI to TS or ST **)
ARC	Arc length of circular curve (SC to CS)
Es	External distance (PI to curve)

* Curve direction shown with an "LT" or "RT" suffix

** Unequal spirals show AD_1 and AD_2 (PI-TS/PI-ST)

The spiral information shall be shown internal to the spiral between the (TS/SC and CS/ST) thus:

Ls	Length of spiral
θ_s	Spiral angle

Compound curve data location is at the discretion of the designer as long as the data is complete.

Compound curve data is separated into two blocks: $R_1, \Delta, \Delta_{C1}, AD_1, ARC_1$ and $R_2, \Delta_{C2}, AD_2, ARC_2$.

Laning

Include all applicable laning lines as depicted on the sample drawing. This should include shoulder, pavement and lane edges, paint lines, gores, crosswalks and stop lines.

AutoCAD's PSLTSCALE variable should be set to 1 to ensure the plotted dimensions of the linetype

patterns (defined in [Section 1250](#)) are maintained regardless of the layout viewport plot scale.

Other Design Details

- Median and lane tapers, additional lanes, barrier flares, bus bays and drainage curbs labelled with their applicable start/end stations
- Sufficient annotation of lane and offset dimensions to clearly define the layout
- Design speed, design vehicle
- Standard symbols and linetypes to define concrete curb and gutter, extruded curb, median and roadside barrier, barrier terminus treatments and structural walls
- Join or match lines, where applicable, with notation of adjoining sheet
- Geometric and Laning series drawings shall be cross-referenced to their Drainage and Spot Elevation series counterparts.
- Arrows indicating direction of travel shall be **hollow**. **Solid arrows** shall only be used on signing and pavement marking drawings as an indication of where and what to paint.

1220.08 SPOT ELEVATIONS

Sample [Figure 1220.J](#)

Spot elevations are required at all L-line intersections with minor and major roads and at all interchanges. Accesses are excluded unless the tie to existing ground is more than 5 m from the normal highway pavement edge. Straightforward, simple spot elevations may be shown on laning and geometric drawings. If the spot elevation requirements are too extensive, a separate set of drawings should be used.

Spot elevations shall be shown in any area where the finished grade and shoulders are not defined by the normal roadway template, superelevation or cross fall rates. Such areas are acceleration and deceleration ramps, tapers, intersection radii and where a new design matches to an existing facility.

For curb and gutter projects, the elevations shall be shown where the asphalt and concrete curb meet.

MoT Section	1220	TAC Section	Not Applicable
-------------	------	-------------	----------------

The increment spacing for spot elevations is left to the designer's discretion. However, 20 m is the maximum with the desirable being a maximum of 10 m at intersections and locations where drainage may prove complicated.

Spot elevations shall be listed to three decimal places. The actual elevation point may be defined with a leader line or marker. Complex spot elevation drawings may use a numbered table format, listing the northing, easting and elevation.

A profile of a travelled edge, as experienced by a driver, is a useful tool for establishing accurate spot elevations.

Spot elevation series drawings shall be cross-referenced to their geometrics and laning, drainage and utility series counterparts.

1220.09 SIGNING AND PAVEMENT MARKINGS

Sample Figure 1220.K

Signing and pavement marking drawings are to be consolidated on a separate set of drawings. **This is intended to be a set of drawings for the use of pavement marking and signing crews.**

Proposed luminaire pole positions must be shown on this drawing. The only signs and luminaires indicated on any of the other drawings will be existing detail on plan sheets.

Reference manuals for signs & pavement markings:

- Manual of Standard Traffic Signs and Pavement Markings
- Pedestrian Crossing Control Manual for British Columbia

The location of both existing and proposed signs shall be shown with the appropriate symbols as listed in [Section 1250.10](#).

These symbols shall represent both existing and proposed appliances. Cross-reference to specialty drawings where special traffic appliances may be required.

All arrows indicating direction of travel shall be **solid arrows** and shall be shown at the actual locations where the arrows are to be painted.

Pavement marking drawings must be drawn to scale (1:500 or 1:250 only).

Refer to text height conventions in Sections [1240.07](#) and [1240.08](#) for the text height to accompany signs.

1220.10 DRAINAGE AND/OR UTILITIES

Sample Figure 1220.L

Drainage and/or utilities drawings shall include a correctly oriented north arrow.

These drawings should clearly portray the drainage / utility design against a screened background of geometrics and laning (see [Section 1240.13](#)).

Existing drainage / utility information shall be shown on these drawings, depicted with standard linetypes and annotated (see [Section 1260](#)).

Aside from the laning, the only geometric information required on these drawings is the reference grid, line designations, station ticks with annotation every 100 m and L-line control points depicted with a circle symbol.

A complex drainage and utility design may require separation into two individual drawings for clarity.

The open and closed drainage system (or utility) designs shall be depicted with the appropriate symbols as shown in [Section 1250](#). Such symbols and general layout procedures shall generally conform to the ministry sample drawing. A benchmark, for the designer, for determining the acceptability of the drawings, is to critique them from a construction contractor's perspective for completeness of information.

Design detail from a separate drawing, that might impact the drainage or utility systems, should be shown in order to alleviate any conflicts. Examples of such details are: special ground treatments (densification), structures (luminaires and sign footings, walls, bridge piers, etc), utilities or drainage.

Drainage and/or utility series drawings shall be cross-referenced to the utility, drainage, geometrics & laning and spot elevation counterparts.

MoT Section	1220	TAC Section	Not Applicable
-------------	------	-------------	----------------

1220.11 PROPERTY ACQUISITION PLANS

Samples Figure 1220.M and 1220.N

As a result of the current legislation governing the acquisition of property for highway construction, it is frequently necessary to initiate negotiations well in advance of project tendering. A set of drawings depicting project R/W requirements is essential to the property acquisition group's ability to proceed.

The Property Acquisition Plan will become the basis for (1) the appraiser to estimate the loss in value for the land required, and (2) for the ministry's representative and the property owner to understand the disturbances and impacts to the property from the taking. This includes any reduction in value to the remainder of the property.

This set of drawings is produced by making duplicates or prints of the project plan plates after the L-line has been established/added. It is desirable to turn off or remove the contours, clearing and grubbing and proposed edge of new pavement lines allowing the R/W drawings to become more legible, especially in urban drawings. Drawings are labelled "Property Acquisition Plan" as a separate note or in the title block, as applicable.

A good liaison with the Property Services Branch is required throughout the design process due to the complexity of property negotiations.

The acquisition plans are a standalone set. Once signed, no revisions are necessary as the design evolves unless there is a direct impact on the R/W requirements. See [Section 1210.06](#) and farther on in [Section 1220.11](#) for further instructions.

Definitions

The ministry and its representatives, while in the process of designing facilities for highway purposes, shall define a requirement to procure titled lands. This procurement may be either temporary or permanent in nature, and may be from either private or publicly held lands. The designer shall additionally define any requirement to procure municipal road areas.

Temporary constitutes a "license" of some type (LTC – License to Construct), and permanent could constitute Statutory Rights-of-Way (SRW) or an acquisition of property in "fee simple" (i.e. ownership).

Statutory Rights-of-Way (SRW)

An SRW grants an interest in the land, but no title. It is for a specific use of the land and is registrable. Registrable SRW's are documents filed as charges against the title of the land in the Land Title Office. It is worded to ensure permanent, continuous entry, egress, passage, installation and maintenance on exactly defined portions of privately owned lands for ministry purposes (e.g. drainage, landscaping).

Leases

A lease is an arrangement where the titleholder grants an interest to another person or party. It is for a definite term and it is registrable.

Licenses

Licenses give the ministry the right to work on private lands for the duration of the project only. For example, the installation of a retaining wall on the R/W boundary where excavation behind the wall may be necessary. However, there is no need for a continued right on the license area extending after construction is complete. Licenses are not registrable and are purely a matter of contract and are revocable. If the form of tenure to the land is an SRW or License as opposed to R/W, then it should be noted on the plan accordingly. Moreover, LTC's must be defined sufficiently (e.g. dimensions) to allow legal survey of the license area in case of expropriation.

Due to their nature, licenses should not be used to gain early entry to private lands that will become R/W due to the risk of revocation or trespass.

Example of a License to Construct

A roadway is in the final stages of construction. A driveway has been provided to a property, and the Ministry did not have to enter the property to join to the existing driveway. The new access is assumed to have an 8% grade.

MoT Section	1220	TAC Section	Not Applicable
-------------	------	-------------	----------------

If the Ministry was to reduce the grade of the driveway, it would require entering and constructing on the property, but the Ministry does not want to pay any settlements for access to property etc.

It would be beneficial to the property owner to give an LTC to the Ministry, waiving all rights and claims, to allow the Ministry to build a driveway having a lesser grade, and perhaps, more to the owners preference.

Please note: Everything that is required for the road and its supporting structures should be purchased and not left on SRW's or LTC's.

Acquisition of Property (Partial or Total Acquisition in Fee Simple)

When the property requirement is of a permanent nature, and the land must be purchased, there are two avenues of direction.

1. The property owner is willing to sell the land and agrees to compensation payable. This is a clear-cut transfer of land in fee simple and can be accommodated with a reference plan.
2. Expropriation Act, RSBC 1996, C.125.

In order to protect the rights of the property owner and to establish a procedure to acquire land for highway purposes, the Expropriation Act was legislated in 1987.

Where a property owner signs an agreement to sell the land but disagrees with the compensation payable, Section 3 of the Act ensures that the compensation payable will be settled by the Supreme Court of BC.

Where an owner disagrees with the ministry regarding the sale of the property and the compensation payable, Section 6 of the Act can be used to obtain the land required. Section 6 of the Act defines the entitlements and the procedures to determine compensation and obtain the land.

Right-of-Way (R/W) Development

The proposed R/W boundary shall be shown with a heavy line symbol as per the standard shown in [Section 1260.05](#). Referencing shall be with one of the following methods, listed in the preferred order:

1. An annotated distance along a property line from an existing survey reference point, i.e., an iron pin, as it allows for minor revisions of the L-line without affecting the boundary. Offsets and/or distances shall be to the nearest 0.1 m.
2. Station and offset from the control line. The station where the offset occurs and the distance to the R/W must be clearly labelled. Refer to sample drawing [Figure 1220.M](#).

The expected accuracy for area calculations is high and steps must be taken to provide a conclusive result. Inaccuracies may result in a second or third acquisition from an owner, or overpayment, with risks to project budget, schedule, and the possibility of expropriation.

Where possible, R/W should be established using the same method as will be used by B.C.L.S. to establish final R/W.

Area calculations shall be done to the highest possible precision by one of the following methods which are listed in the preferred order:

1. AutoCAD using applicable geometry
2. On an original mylar/vellum, using applicable geometry
3. Electronic methods such as digitizing tables
4. Planimeter using the average of four readings

Drawing Content

Clearing and grubbing areas shall not be shown on Property Acquisition Plans.

Each parcel of land, enclosed within the R/W and including existing R/W, will have the area shown to the precision shown in "General Survey Instructions to British Columbia Land Surveyors", published by the Surveyor General and reprinted below.

Up to 0.1 ha	quote to 0.0001 ha
From 0.1 ha up to 1 ha	quote to 0.001 ha
From 1 ha up to 10 ha	quote to 0.01 ha
From 10 ha up to 100 ha	quote to 0.1 ha
From 100 ha and over	quote to 1 ha

Individual areas shall be outlined by a box in order to make them easily distinguishable from other plan information.

MoT Section	1220		TAC Section	Not Applicable
-------------	------	--	-------------	----------------

Remaining portions of a parcel that have been severed by the proposed highway R/W shall also have areas calculated and labelled as previously defined.

Other than in subdivisions, a table of the areas involved with applicable comments may be located on the drawing containing the largest “take” for that lot. The comments should cross reference the adjacent drawing noting the smaller “take” for that lot.

If one table is all that is required, it is preferable to locate it on the first drawing of the set of acquisition drawings.

If there are many individual areas or several tables, one alternative is to list all tables on one drawing sheet, preferably located at the rear of all acquisition drawings.

Another alternative is to provide an index of tables with applicable drawing numbers to be located on the first Property Acquisition Plan.

Another alternative for larger projects is to provide a table of areas (for each property impacted) per drawing sheet. The table should be located in unobtrusive areas of the plan, and split if necessary, so as to not hide information.

When there is more than one area “take” from a parcel, the drawing numbers will be listed beside the areas. Areas shall be subtotaled per parcel. Refer to the sample table below

Legal Description	New R/W Required	R/W Inside	R/W Outside	License to Construct	Comments
Lot 1, Plan 6976, D.L. 47965	0.0737 ha Dwg-09RW				
Plan 1799-RW			0.0499 ha Dwg-09RW		Encroachment (Northern Railway)
Plan H-275		0.154 ha Dwg-09RW 1.54 ha Dwg-09RW 0.287 ha Dwg-09RW 2.17 ha Dwg-09RW Total 4.15 ha	3.00 ha Dwg-09RW 1.47 ha Dwg-09RW 0.399 ha Dwg-09RW 0.541 ha Dwg-09RW 0.0202 ha Dwg-09RW Total 5.43 ha		Outside Area is Surplus

For urban street design projects, all R/W areas to be shown to the nearest 0.1 m². Areas to be calculated using appropriate geometry. Do NOT use planimeter.

MoT Section	1220	TAC Section	Not Applicable
-------------	------	-------------	----------------

Right-of-Way Plans – Delivery Package

A delivery package of right-of-way plans shall include the following:

- One set (full size and half size) of all project contract drawings including plans, laning, cross-sections and profiles, unsigned is acceptable
- One copy of area summaries from the Design Folders, form H749
- The Property Acquisition Plan AutoCAD file on CD or DVD disc for the B.C.L.S

Property Acquisition Plans – Check List

- North arrow
- Title block
- Scale and scale bar (metric)
- Table of areas involved and comments
- R/W and dimensions for each parcel
- A sufficient amount of the legal description should be shown on the plan to correctly identify the property. Some legal descriptions are too long to enter in full. In the alternative, use the Land Title Office property identifier (PID) numbers to legally define the property.
- Project number
- All utility poles, buildings, fences, existing land improvements (including underground improvements such as storage tanks) and accesses within 10 m of the proposed R/W and all improvements beyond the 10 m that are impacted by the R/W, accesses and construction but never less than 30 m from centre line
- Existing accesses should be marked to indicate whether the access remains open, to be closed or relocated
- Proposed toes with cut/fill points annotated at transition points
- Obtain all pertinent signatures
- Section 42, and Section 64 gazetted road (all old road) plotted inside/outside the new R/W
- Easement/utility R/W
- Co-ordinate listing (if available)

- All “I.P.’s” and monuments that are found are symbolized. All I.P.’s and monuments that cannot be found, are not to be indicated on the plans
- A “For Property Acquisition Only” stamp, if applicable. (Required on small contract not using separate Property Acquisition Plans)
- Note any and all surveys or plan numbers on the drawing; it is all useful information
- If the area appears to be convoluted, outline the area to be acquired in red pencil on a separate print. If your computer system is appropriate, this may be done automatically.
- Clear and grub line and areas are **not** to be shown

Old Road Areas

There has been some confusion regarding the method of handling old road areas on our plans where the old road does not have a surveyed R/W, or its boundary has not been established by adjacent subdivision.

Section 42 roads are such a case. The following procedure shall apply:

1. All old roads are to be checked with the Regional Office for possible “Gazette Notice”. If there is a Gazette notice, the gazetted width shall be indicated on the plans with a line type similar to that used for “Clearing and Grubbing” and labelled as “R/W established by B.C. Gazette dated _____”.
2. If a Gazette Notice is not in existence, the area of existing road shall be that of the “travelled way”. The travelled way is defined as the width between the outer edges of the road shoulders. It is necessary, therefore, to show on the plans the plotted position of the edge of shoulders obtained by occasional measurement. The area shall be calculated by estimating the average width within each lot.

MoT Section	1220	TAC Section	Not Applicable
-------------	------	-------------	----------------

1220.12 VOLUME OVERHAUL DIAGRAM

Sample Figures [1220.O](#), [1220.P](#), [1220.Q](#)

A volume overhaul diagram provides a convenient method for studying haul and overhaul and for estimating payments. It is a continuous curve showing the accumulated algebraic sum of volumes [cuts (+) and fills (-)] from the beginning station through the entire project for each individual alignment.

The X-axis (abscissa) is the stationing. The Y-axis (ordinate) represents the tabulated cumulative volume of cut and fill between successive cross sections.

For small projects, cross section areas are calculated, cut and fill volumes are tabulated to give algebraic sum of volumes at each station and the cumulative total. This cumulative total is the ordinate for the volume overhaul diagram.

Cut volumes are adjusted for swell or shrinkage before solving ordinates. Typical adjustment values are shown in the table below.

Material*	Factor	Comment
Type A	20% Swell	Solid rock and rock stratum
Type B	1% Shrinkage 10% Shrinkage	Clean broken rock Granular materials
Type C	Unadjusted	
Type D	15% Shrinkage 20% Shrinkage	Granular materials Fine-grained silts or clays

*See Standard Specifications 201.11 for exact definitions of Material Types.

Payment for excavation is made at a bid price per cubic metre. This unit price includes payment for excavating and loading material, transporting it any distance less than the freehaul limit and placing it in the fill. The ministry freehaul limit is typically 300 m. The freehaul volumes are determined by offsetting the ordinate line horizontally and re-plotting the ordinates until an intersecting line is reached.

Above the balance line, the freehaul is measured from the bottom of the cut slopes and/or at balance points to the right. Below the balance line, the freehaul is measured from the top of the cut slopes and/or balance points to the left. The resultant freehaul is the shaded area on the Volume Overhaul Diagram. If material is brought in from a pit, the deadhaul distance from the pit to the road is subtracted from 300 m to solve the remaining freehaul.

It is often necessary to move excavated material beyond the stipulated freehaul distance. This operation is called overhaul. The unit in which overhaul is computed is the "station m". One "station m" is one cubic metre of excavated material moved one 100 m station.

Overhaul areas are the unshaded portions of the volume overhaul diagram. Overhaul volumes are determined as individual areas multiplied by the percentage of each material type times their appropriate swell or inverse shrinkage factor.

Diagram Characteristics

1. A rising line indicates that the excavation quantity is larger than the embankment quantity at that point on the roadway; a falling line indicates the reverse.
2. Steep slopes indicate large differences between cuts and fills at the section; flat slopes indicate small differences.
3. Points of zero slope (top and bottom of curve) indicate changing from an excess of cut to an excess of fill or vice versa.

See [Figure 1220.O](#) for sample overhaul calculations

When Haul is Included in the Bid Price

When haul is included in the bid price, the volume overhaul drawings are "for information only" and a note to this effect must be placed on each drawing.

MoT Section	1220	TAC Section	Not Applicable
-------------	------	-------------	----------------

1220.13 GRAVEL QUANTITY AND HAUL CHARTS

Sample Figure 1220.R

The following materials are to have their own quantity and haul charts:

1. High fines 25 mm surfacing aggregate
2. Crushed base course aggregates:
Nominal sizes can be 25, 50 or 75 mm
Specify as: Well, Intermediate or Open-Graded
3. Select Granular Sub-Base
4. Gravel facing
5. Gravel blankets
6. Gravel filter layers
7. Bridge end fills
8. Structural backfill for bin walls and structural steel plate culverts

Haul charts are not required for materials that are to be supplied in place, as bid price includes haul. However, haul charts for such items would assist in bid preparation.

Description of Sample Gravel Quantities and Haul Chart (Figure 1220.R)

Items numbered on chart as follows:

Quantity Charts

1. Project kilometre columns labelled every kilometre. Distances are to scale.
2. Material type headings
3. Quantity required in the kilometre interval. Enter NIL for columns where quantity is "0". All quantities are in unit tonnes.
4. Calculated quantity for fraction of km at end of project
5. Total project quantities for each material type
6. Sum of total project quantities

Haul Charts

7. Heading of haul chart. Consists of material type and origin of material.
8. Haul km. Km distance from supply location (Pit, stockpile, etc.)
9. Identification of material source, its distance from the project, and an arrow indicating where the hauled material enters the project
10. Total hauled material for first km minus freehaul distance for each direction of haul. Haul quantities are in unit tonnes. Distances are to scale.
11. Haul for each subsequent km. Distances are to scale.
12. Total km haul
13. Sum of total km haul

Haul Summary

14. Total haul of all materials for each km.
15. Sum of total km haul of all materials.

Haul / Freehaul Notes

For Asphalt Concrete: Pavement / Levelling Course

Payment will be at the unit price bid per tonne, supplied in place. As such, these items are not usually included in the haul chart. Their inclusion is useful in bid preparation.

For Material Stockpiled Prior to Placement

Haul will be measured from the original point of production via the stockpile to the delivery point minus 1 kilometre freehaul.

For Material Placed Directly on Highway

Haul will be measured from the point of production to the delivery point minus 1 kilometre freehaul.

For Material Produced for Stockpiling Only

Haul will be measured from the point of production to the stockpile location minus 1 kilometre freehaul.

MoT Section	1220	TAC Section	Not Applicable
-------------	------	-------------	----------------

FIGURE 1220.O SAMPLE OVERHAUL TABULATION CHART

MINISTRY OF TRANSPORTATION AND INFRASTRUCTURE ENGINEERING BRANCH OVERHAUL								
PROJECT NAME <u>Tabor Mountain - Willow River</u>			MADE BY <u>J.H. Cooper</u>			SHEET <u>1</u> OF <u>1</u>		
HIGHWAY <u>HWY No. 16</u>			CHECKED BY <u>G. Hall</u>			DATE <u>APRIL 2006</u>		
A		B		C	D	E	F	
STATIONS		STATIONS		AREA cm ²	SCALE FACTOR	MATERIAL TYPE	FACTOR	OVERHAUL (B x C x D x E) Sta. m
103+00	103+60	104+05		0.60	1 000	100% D	1.20	720
107+55	111+35	124+06	124+55	105.50	1 000	100% D	1.20	126 600
111+35	112+35	118+40	119+25	20.10	1 000	100% A	0.833	16 743
122+37	123+65	124+06		7.90	1 000	60% A	0.833	3 948
122+37	123+65	124+06		7.90	1 000	40% D	1.20	3 792
								151 083
124+55	124+65	127+10	127+45	4.50	1 000	100% A	0.833	3 749
133+20	134+70	134+70		2.40	1 000	100% A	0.833	1 999
								TOTAL
								157 551
<p>NOTE: To be used in conjunction with Sample Volume Overhaul Diagram</p> <p>On SCHEDULE 7 we show overhaul quantities in 1000 Sta. m; therefore, divide above Sta. m by 1000 and show: 157.6</p>								

Form H 759

MoT Section	1230	TAC Section	Not Applicable
-------------	------	-------------	----------------

1230 AUTOCAD LAYERS

1230.01 REVISED STANDARDS

The ministry Highway Engineering AutoCAD layer standards were revised in spring 2010, taking effect May 1 for new projects.

The previous standard listed approximately 50 layers grouped by type of drawing with a variable single letter prefix to identify the office.

Examples: FDET-ROADS (survey office, existing road detail), XDES-LANE (consultant office, design or proposed laning).

1230.02 NCS LAYER STANDARD

General Information

The United States National CAD Standard (NCS) version 4.0 (current as of January 2008) defines a layer naming convention and specific layer codes for multiple disciplines. The standard includes specifications for symbols, linetypes, plot styles, drawing set organization, drafting conventions and other CAD related functions.

Ministry Adoption

The ministry has adopted only the layer naming convention specified by NCS 4.0 with restrictions and the following two additions:

- Use of three additional major codes PROF, STRC and UTIL
- Use of an alignment name in place of a minor code (eg. L100A1, E100)

No other modifications to the standard are permitted at this time.

NCS Layer Name Format

The format of an NCS layer name is as follows:

DD-MAJR-MINR-MINR-S

The NCS Discipline Designator is 1 or 2 characters, Major/Minor codes are 4 characters and the Status indicator is 1 character. The maximum length of an NCS layer is therefore 19 characters. The minimum length is 6 characters (D-MAJR).

Approved Discipline Designators

The ministry has defined the following approved discipline designators.

DD – Approved Discipline Designators	
B	Geotechnical
C	Civil (design detail)
G	General (titleblocks, viewports, etc.)
S	Structural (bridge drawings only)
V	Survey / Mapping (survey detail)

Approved Major Group Codes

The ministry has defined the following major group codes. Three are non-standard (PROF, STRC, UTIL).

MAJR – Approved Major Group Codes	
ALGN	Alignment
ANNO	Annotation
BORE	Borings
COMM	Communications
CTRL	Control points
DRAN	Drains
IRRG	Irrigation
NGAS	Natural gas
OIL~	Oil
POWR	Power
PROF	Profiles
PROP	Property boundary
RAIL	Railway
ROAD	Roadways
RWAY	Right-of-way
SECT	Section
SIGN	Sign
SITE	Site features
SSWR	Sanitary Sewer
STRC	Structures
STRM	Storm Sewer
SURV	Survey (general survey)
TOPO	Topographic feature
UTIL	Miscellaneous utilities
WATR	Water supply

MoT Section	1230	TAC Section	Not Applicable
-------------	------	-------------	----------------

Major and Minor Code Usage Rules

As per the NCS 4.0 standard, any major code may be used as a minor code.

Each NCS code comes with a general description. When a layer name is created, its description and the contents of the layer should not alter the meanings of those general descriptions.

For example, the minor code PENS (Penstock) may be used to diagram a pipe that delivers water to a sewage system or water to a turbine in a hydro dam. However, PENS may not be re-purposed to outline an enclosure for confining livestock.

Custom four letter minor group codes may be created as necessary. The tilde character (~) is used as filler to fulfill the four character requirement.

Ministry Restrictions – Additional Layers

1. The ministry provides a standard set of layers. The content placed on those layers should be based on the descriptions provided.
2. Where one or both minor group codes are not specified, additional layers may be created by appending allowable minor group codes.
3. Appending a general purpose annotation minor group code such as ANNO or TEXT is permitted without ministry consultation.
4. The V-SURV-SPOT-<KCFC> layers use CAiCE feature codes as the second minor code (e.g. V-SURV-SPOT-AN~~ for Spot Elevations - Anchor). These layers may be useful for a finer grained control over spot elevation visibility.
5. For layers C-ALIGN, C-ROAD-TOES and V-ALIGN, an alignment name may be used as a minor group code (see [Section 1230.03 – Layer Name](#)).
6. Descriptions shall be added to the AutoCAD layer table.

All other additions (including status codes) should be submitted prior to use. Cooperation will ensure that layers are being used as intended and that conflicting layers are not being created.

As the standard evolves, the approved layer list may be modified. Suggestions for layer changes should be submitted to the ministry Engineering Branch, Geometric Standards Section.

1230.03 LAYER TABLE PROPERTIES

AutoCAD's layer table contains a number of properties (columns) that will be used to control the appearance of all drawing objects.

All drawing objects are to have their applicable properties set to ByLayer to take advantage of the layer control features.

Standards compliance for a specific drawing can then be assured by verifying the correctness of the layer table and by confirming that all objects are using the ByLayer attributes.

Layer Name

The layer name will follow the format DD-MAJR or DD-MAJR-MINR or DD-MAJR-MINR-MINR where:

- DD is a single letter discipline designator taken from the approved list
- MAJR is the major group code taken from the approved list
- MINR is a minor group code:
 - Length is four letters, uses tilde (~) characters for filler as necessary
 - Taken from the NCS minor group list if the NCS description fits
 - Custom codes are allowed
- For the C-ALGN, C-ALGN-CURV, C-ALGN-MAJR, ... layers and V-ALGN equivalents, the alignment name may be inserted in the layer name as the first minor group code (e.g. C-ALGN-L100A1 or V-ALGN-E100-TEXT)
- For the V-SURV-SPOT layer, additional layers may be created for individual CAiCE features codes (e.g. V-SURV-SPOT-AN~~ for General Survey - Spot Elevations - Anchor.
- All letters are uppercase

Note that the MAJR and MINR placeholders used above represent all possible major and minor NCS group codes. However, "MAJR" and "MINR" are themselves commonly used minor group codes.

MoT Section	1230	TAC Section	Not Applicable
-------------	------	-------------	----------------

Layer Description

The layer descriptions are provided by the ministry, additional layers are to be described using the same format.

Layer On/Freeze

Entities on layers that are off or frozen are not visible and will not plot in model space, paper space or in any layout viewport.

If the drawing is x-referenced into another drawing the on/freeze statuses of the xref layers may be adjusted without affecting the original drawing.

Other Effects of Off Layers

Layers that are off (not frozen) are still part of the drawing and are analyzed during typical operations. For example, the quick select command should be used with caution since it can be used to select, move, copy or delete objects on an “off” layer.

Other Effects of Frozen Layers

Objects on layers that are frozen are not selectable or changeable and are ignored for drawing extents, hatching or regen type calculations. Freezing layers may improve AutoCAD’s performance.

Blocks or XREFs on Layers that are Frozen

Blocks or x-references inserted on layers that are frozen are not visible even if the internal entities are on visible layers.

Blocks or XREFs on Layers that are Off

Blocks inserted on layers that are off may be visible if their internal entities reside on visible layers.

The visibility of xref drawing entities is not affected by the layer containing the xref being off because the internal entities are always on another layer.

Layer Lock

Entities on locked layers cannot be modified.

Layer Colour

The colour attribute for all entities should be set to ByLayer. The only exception is internal block entities for multi-colour blocks such as the titleblock.

Layer colours are chosen to differentiate existing data from design data.

Layer Color	Usage
1-9, 250-255	Common
12, 16	Bridge
30, 36, 165, 202, 241	Design
10, 11, 22, 32	Survey
50, 53, 74, 83, 90	
116, 133, 135, 150, 155, 170	
200, 210, 231	

Layer Linetype

The Linetype attribute for all entities should be set to ByLayer. Most layers are assigned a Continuous linetype.

Layers such as C-SSWR-PIPE have a custom linetype assigned. Polylines assigned to these layers will automatically display the correct pattern.

Related text labels and other AutoCAD entities not affected by linetype may also be added to these layers.

MoT Section	1230	TAC Section	Not Applicable
-------------	------	-------------	----------------

Layer Lineweight

The Lineweight attribute for all entities should be set to ByLayer.

Layer lineweight is primarily used for on-screen viewing. There is an on/off toggle on the status bar for this purpose.

Current LCD display technology (85-140 dpi) is too low to make this feature useful at present so the toggle is generally left off.

Where weight is concerned, the largest group of layers is the 0.25 mm layers and those are assigned a lineweight of “Default”.

“Default” is defined as “0.25 mm” in the lineweight settings dialog. Using “Default” instead of “0.25 mm” in the layer table improves AutoCAD’s performance significantly.

Using Layer Lineweight for Plotting

Some jurisdictions use the layer lineweight to determine plot lineweight. However, ministry STB plot styles use numerical weights because of the requirement for thinner lines on half-size plots.

Layer Transparency

The Transparency attribute for all entities should be set to ByLayer. All standard ministry layers have the transparency set to 0.

Transparency varies between 0 (full color) and 100 (fully transparent or invisible) and may be useful for raster images or fading the intensity of survey data.

As this feature is not available in all versions of AutoCAD, and the side effects are not known, the recommended method for screening existing detail in design plots is to alter the plot style for those layers (see [Section 1240.13](#)).

Layer Plot Style

The Plot Style attribute for all entities should be set to ByLayer. One plot style name (from a predefined list) is assigned to each layer. This will determine the plotting attributes for all entities on the layer.

The plot dialog allows an STB file to be assigned to each layout. The STB file contains the definitions for the plot style names.

Each ministry STB file contains an identical list of plot style names with different definitions. Selecting a particular STB file determines whether the plot is color or black/grey and whether the pen widths are full size or half size.

[Section 1240](#) contains additional details regarding the ministry plot style standards.

Layer Plot On/Off

Certain layers are defined as global non-plotting layers (e.g. G-ANNO-VPRT for layout viewports). This setting allows layer entities to be seen on-screen but not on the plot.

Layer Settings Per Viewport

Additional viewport specific columns have been added to the layer table in recent versions of AutoCAD.

This list now includes: VP Freeze, VP Color, VP Linetype, VP Lineweight, VP Transparency and VP Plot Style.

These settings allow individual layers to be frozen or the color, linetype, lineweight, transparency or plot style to be adjusted on a per viewport basis when plotting from a layout.

MoT Section	1230	TAC Section	Not Applicable
-------------	------	-------------	----------------

1230.04 LAYER LIST

NCS LAYER	COLOR	LINETYPE	WEIGHT	PLOT STYLE	DESCRIPTION (see notes at the bottom of the table)
B-ANNO-LEGN	1	Continuous	0.25 mm	Color-Black 25	Geotech - Annotation - Legends
B-ANNO-NOTE	1	Continuous	0.25 mm	Color-Black 25	Geotech - Annotation - Notes
B-ANNO-TEXT	251	Continuous	0.13 mm	Grey 40% 13	Geotech - Annotation - Text
B-BORE-ESWT	5	GEO-WTE	0.25 mm	Color-Grey 60% 25	Geotech - Estimated Water Table Elevation
B-BORE-MSWT	5	GEO-WTM	0.25 mm	Color-Grey 60% 25	Geotech - Measured Water Table Elevation
B-BORE-SPLN	1	Continuous	0.25 mm	Color-Black 25	Geotech - Seismic Profile Line
B-BORE-SYMB	241	Continuous	0.25 mm	Black 25	Geotech - Symbols
B-BORE-SYMB-FEAT	1	Continuous	0.25 mm	Color-Black 25	Geotech - Symbols - Feature with Attribute
B-BORE-SYMB-HOLE	1	Continuous	0.25 mm	Color-Black 25	Geotech - Symbols - Auger Hole or Borehole
B-BORE-SYMB-HUBA	1	Continuous	0.25 mm	Color-Black 25	Geotech - Symbols - Hub with Attribute
B-BORE-SYMB-TEST	2	Continuous	0.35 mm	Black 35	Geotech - Symbols - Test Instruments
B-BORE-SYMB-THOL	1	Continuous	0.25 mm	Color-Black 25	Geotech - Symbols - Testhole
B-BORE-SYMB-TPIT	1	Continuous	0.25 mm	Color-Black 25	Geotech - Symbols - Testpit
C-ALGN	4	Continuous	0.70 mm	Color-Black 70	Alignment - Base Layer
C-ALGN-ANNO	1	Continuous	0.25 mm	Color-Black 25	Alignment - Minor Labels (Coordinates, Bearings)
C-ALGN-CURV	2	Continuous	0.35 mm	Black 35	Alignment - Curve and Spiral Data
C-ALGN-L100A1	4	Continuous	0.70 mm	Color-Black 70	Alignment - Specific Alignment
C-ALGN-L100A1-ANNO	1	Continuous	0.25 mm	Color-Black 25	Alignment - Minor Labels (Coordinates, Bearings)
C-ALGN-L100A1-CURV	2	Continuous	0.35 mm	Black 35	Alignment - Curve and Spiral Data
C-ALGN-L100A1-MAJR	2	Continuous	0.35 mm	Black 35	Alignment - 100m Major Tics and Text
C-ALGN-L100A1-MINR	1	Continuous	0.25 mm	Color-Black 25	Alignment - 20m Minor Tics
C-ALGN-L100A1-TEXT	2	Continuous	0.35 mm	Black 35	Alignment - Major Labels (POTs, Pls, Curve Points)
C-ALGN-LOCN	3	Continuous	0.50 mm	Color-Black 50	Alignment - Limit of Construction
C-ALGN-MAJR	2	Continuous	0.35 mm	Black 35	Alignment - 100m Major Tics and Text
C-ALGN-MINR	1	Continuous	0.25 mm	Color-Black 25	Alignment - 20m Minor Tics
C-ALGN-NOTE	2	Continuous	0.35 mm	Black 35	Alignment - Notations
C-ALGN-TEXT	2	Continuous	0.35 mm	Black 35	Alignment - Major Labels (POTs, Pls, Curve Points)
C-COMM	1	Continuous	0.25 mm	Color-Black 25	Telephone and Cable - Base Layer
C-COMM-CNDT	3	UG-TEL	0.50 mm	Color-Black 50	Telephone and Cable - Underground Conduit
C-COMM-SYMB	1	Continuous	0.25 mm	Color-Black 25	Telephone and Cable - Symbols
C-COMM-TEXT	1	Continuous	0.25 mm	Color-Black 25	Telephone and Cable - Text
C-DRAN	3	Continuous	0.50 mm	Color-Black 50	Drainage - Base Layer
C-DRAN-CBAS	1	Continuous	0.25 mm	Color-Black 25	Drainage - Catch Basin
C-DRAN-CULV	4	Continuous	0.70 mm	Color-Black 70	Drainage - Culvert
C-DRAN-CULV-TEXT	2	Continuous	0.35 mm	Black 35	Drainage - Culvert Text
C-DRAN-DTCH	3	Continuous	0.50 mm	Color-Black 50	Drainage - Ditch
C-DRAN-DTCH-CNTR	3	HYD-CNTR	0.50 mm	Color-Black 50	Drainage - Ditch Centre
C-DRAN-RRAP	1	CONST-RRAP	0.25 mm	Color-Black 25	Drainage - Riprap
C-DRAN-SWAY	1	Continuous	0.25 mm	Color-Black 25	Drainage - Spillway
C-DRAN-TEXT	2	Continuous	0.35 mm	Black 35	Drainage - Notes
C-NGAS	3	Continuous	0.50 mm	Color-Black 50	Natural Gas - Base Layer
C-NGAS-PIPE	3	UG-GAS	0.50 mm	Color-Black 50	Natural Gas - Pipeline
C-NGAS-SYMB	1	Continuous	0.25 mm	Color-Black 25	Natural Gas - Symbols
C-NGAS-TEXT	3	Continuous	0.50 mm	Color-Black 50	Natural Gas - Text
C-OIL~	3	Continuous	0.50 mm	Color-Black 50	Oil - Base Layer
C-OIL~-SYMB	1	Continuous	0.25 mm	Color-Black 25	Oil - Symbols
C-OIL~-TEXT	3	Continuous	0.50 mm	Color-Black 50	Oil - Text
C-OIL~-UGND	3	UG-OIL	0.50 mm	Color-Black 50	Oil - Underground
C-POWR	1	Continuous	0.25 mm	Color-Black 25	Electrical Power - Base Layer
C-POWR-CNDT	3	UG-ELEC	0.50 mm	Color-Black 50	Electrical Power - Underground Conduit
C-POWR-SYMB	1	Continuous	0.25 mm	Color-Black 25	Electrical Power - Symbols
C-POWR-TEXT	1	Continuous	0.25 mm	Color-Black 25	Electrical Power - Text
C-PROF	4	Continuous	0.70 mm	Color-Black 70	Profiles - Base Layer
C-PROF-ALGN	4	Continuous	0.70 mm	Color-Black 70	Profiles - Design Profile
C-PROF-ALGN-HILO	2	Continuous	0.35 mm	Black 35	Profiles - Design Profile - High Points and Low Points
C-PROF-ALGN-TEXT	2	Continuous	0.35 mm	Black 35	Profiles - Design Profile - Text

MoT Section	1230	TAC Section	Not Applicable
-------------	------	-------------	----------------

NCS LAYER	COLOR	LINETYPE	WEIGHT	PLOT STYLE	DESCRIPTION (see notes at the bottom of the table)
C-PROF-DRAN	5	Continuous	0.25 mm	Color-Grey 60% 25	Profiles - Drainage
C-PROF-DRAN-TEXT	5	Continuous	0.25 mm	Color-Grey 60% 25	Profiles - Drainage Text
C-PROF-EXST-DRAN	165	Continuous	0.25 mm	Grey 60% 25	Profiles - Existing Detail - Drainage
C-PROF-EXST-GRND	165	Continuous	0.25 mm	Grey 60% 25	Profiles - Existing Detail - Existing Ground
C-PROF-EXST-ROCK	165	Continuous	0.25 mm	Grey 60% 25	Profiles - Existing Detail - Rock Stratum
C-PROF-EXST-TEXT	165	Continuous	0.25 mm	Grey 60% 25	Profiles - Existing Detail - Text
C-PROF-EXST-UTIL	165	Continuous	0.25 mm	Grey 60% 25	Profiles - Existing Detail - Utilities
C-PROF-GRID-LABL	1	Continuous	0.25 mm	Color-Black 25	Profiles - Grid - Grid Labels
C-PROF-GRID-MAJR	1	Continuous	0.25 mm	Color-Black 25	Profiles - Grid - Major Grid Lines
C-PROF-GRID-MINR	251	Continuous	0.13 mm	Grey 40% 13	Profiles - Grid - Minor Grid Lines
C-PROF-HORZ-DATA	2	Continuous	0.35 mm	Black 35	Profiles - Horizontal - Superelevation
C-PROF-HORZ-LINE	3	Continuous	0.50 mm	Color-Black 50	Profiles - Horizontal - Lines
C-PROF-HORZ-LOCN	3	Continuous	0.50 mm	Color-Black 50	Profiles - Horizontal - Limit of Construction
C-PROF-HORZ-TEXT	2	Continuous	0.35 mm	Black 35	Profiles - Horizontal - Text
C-PROF-HORZ-XING	1	Continuous	0.25 mm	Color-Black 25	Profiles - Horizontal - Crossing Chains
C-PROF-QUAN	2	Continuous	0.35 mm	Black 35	Profiles - Quantities
C-PROF-STRM	1	Continuous	0.25 mm	Color-Black 25	Profiles - Closed Drainage
C-PROF-STRM-TEXT	1	Continuous	0.25 mm	Color-Black 25	Profiles - Closed Drainage - Text
C-ROAD	1	Continuous	0.25 mm	Color-Black 25	Roads - Base Layer
C-ROAD-AREA-TEMP	7	Continuous	0.35 mm	Black 35	Roads - Area Takeoffs for Calculations
C-ROAD-ARRW	1	Continuous	0.25 mm	Color-Black 25	Roads - Direction Arrow (plan annotation)
C-ROAD-BARM-CABL	6	BAR-CABLE	0.25 mm	Color-Black 25	Roads - Median Barrier - Cable
C-ROAD-BARM-CONC	6	BAR-MB	0.25 mm	Color-Black 25	Roads - Median Barrier - Concrete
C-ROAD-BARM-GRAL	6	Continuous	0.25 mm	Color-Black 25	Roads - Median Barrier - Steel Guard Rail
C-ROAD-BARR-CABL	6	BAR-CABLE	0.25 mm	Color-Black 25	Roads - Roadside Barrier - Cable
C-ROAD-BARR-CONC	6	BAR-RB	0.25 mm	Color-Black 25	Roads - Roadside Barrier - Concrete
C-ROAD-BARR-GRAL	3	BAR-GUARD	0.50 mm	Color-Black 50	Roads - Roadside Barrier - Guard Rail (Steel)
C-ROAD-BARR-PNEB	6	Continuous	0.25 mm	Color-Black 25	Roads - Roadside Barrier - Not Controlled by Pavement
C-ROAD-CNTR	6	ALGN-CNTR	0.25 mm	Color-Black 25	Roads - Centreline (if alignment is offset from centre)
C-ROAD-CURB	6	Continuous	0.25 mm	Color-Black 25	Roads - Curb
C-ROAD-CURB-ASPH	3	Continuous	0.50 mm	Color-Black 50	Roads - Curb - Asphalt
C-ROAD-CURB-CONC	6	Continuous	0.25 mm	Color-Black 25	Roads - Curb - Concrete
C-ROAD-CURB-TEXT	6	Continuous	0.25 mm	Color-Black 25	Roads - Curb - Description (label curb start, end and
C-ROAD-DRIV	1	Continuous	0.25 mm	Color-Black 25	Roads - Driveway
C-ROAD-GRVL-SHLD	1	Continuous	0.25 mm	Color-Black 25	Roads - Gravel Shoulder
C-ROAD-GUTR	6	Continuous	0.25 mm	Color-Black 25	Roads - Gutter
C-ROAD-LANE	2	Continuous	0.35 mm	Black 35	Roads - Lane Edge
C-ROAD-LANE-TEXT	1	Continuous	0.25 mm	Color-Black 25	Roads - Lane Text
C-ROAD-MRKG-ARRW	1	Continuous	0.25 mm	Color-Black 25	Roads - Pavement Marking - Direction Arrow
C-ROAD-MRKG-BRKN	2	ALGN-BWL	0.35 mm	Black 35	Roads - P... - Broken White Line - Rural Paintline
C-ROAD-MRKG-BUSB	2	ALGN-BWL-PUL	0.35 mm	Black 35	Roads - P... - Broken White Line - Bus Bay Pullout
C-ROAD-MRKG-CHEV	6	Continuous	0.25 mm	Color-Black 25	Roads - P... - Chevrons
C-ROAD-MRKG-DECL	2	ALGN-DECL	0.35 mm	Black 35	Roads - P... - Deceleration or Acceleration Lane
C-ROAD-MRKG-IGLN	2	ALGN-IGL	0.35 mm	Black 35	Roads - P... - Intersection/Bicycle Guiding Line
C-ROAD-MRKG-LNEG	5	Continuous	0.25 mm	Color-Grey 60% 25	Roads - P... - Lane Edge
C-ROAD-MRKG-MEDN	5	Continuous	0.25 mm	Color-Grey 60% 25	Roads - P... - Median
C-ROAD-MRKG-RCLN	2	ALGN-BWL-CIRC	0.35 mm	Black 35	Roads - P... - Broken ... - Roundabout Circulating Lane
C-ROAD-MRKG-RSLN	2	ALGN-BWL-RES	0.35 mm	Black 35	Roads - P... - Broken ... - Reserved Lane
C-ROAD-MRKG-RYLN	2	ALGN-BWL-YIELD	0.35 mm	Black 35	Roads - P... - Broken ... - Roundabout Yield Line
C-ROAD-MRKG-UPLN	2	ALGN-BWL-URB	0.35 mm	Black 35	Roads - P... - Broken ... - Urban Paintline
C-ROAD-MRKG-WHIT	2	Continuous	0.35 mm	Black 35	Roads - P... - White Line
C-ROAD-MRKG-YELO	2	Continuous	0.35 mm	Black 35	Roads - P... - Yellow Line
C-ROAD-PATT-BNDY	7	Continuous	0.35 mm	Black 35	Roads - Shade Boundary
C-ROAD-PATT-SHD1	251	Continuous	0.13 mm	Grey 40% 13	Roads - Shade Pattern 1
C-ROAD-PATT-SHD2	253	Continuous	0.25 mm	Grey 60% 25	Roads - Shade Pattern 2
C-ROAD-PVMT-EDGE	3	Continuous	0.50 mm	Color-Black 50	Roads - Edge of Pavement
C-ROAD-RAIS	3	Continuous	0.50 mm	Color-Black 50	Roads - Raised Island or Median

MoT Section	1230	TAC Section	Not Applicable
-------------	------	-------------	----------------

NCS LAYER	COLOR	LINETYPE	WEIGHT	PLOT STYLE	DESCRIPTION (see notes at the bottom of the table)
C-ROAD-RAIS-DETL	1	Continuous	0.25 mm	Color-Black 25	Roads - Raised Island or Median - Details (Letdowns /
C-ROAD-RAIS-PATT	1	Continuous	0.25 mm	Color-Black 25	Roads - Raised Island or Median - Shading
C-ROAD-SHLD	1	ALGN-SHLD	0.25 mm	Color-Black 25	Roads - Shoulder of Fill
C-ROAD-SWLK	2	Continuous	0.35 mm	Black 35	Roads - Sidewalk
C-ROAD-TEXT	1	Continuous	0.25 mm	Color-Black 25	Roads - Geometry Text
C-ROAD-TOES	6	TOES-TOE	0.25 mm	Color-Black 25	Roads - Toes
C-ROAD-TOES-BBEF	6	TOES-BBEF	0.25 mm	Color-Black 25	Roads - Toes - Base of Bridge End Fill
C-ROAD-TOES-BERM	1	CONST-BERM	0.25 mm	Color-Black 25	Roads - Toes - Berm in Cut or Fill
C-ROAD-TOES-L100A1	1	Continuous	0.25 mm	Color-Black 25	Roads - Toes for Specific Alignment
C-ROAD-TOES-SHEX	6	TOES-SHEX	0.25 mm	Color-Black 25	Roads - Toes - Shoulder Excavation
C-ROAD-TOES-SURF	1	TOES-TOE	0.25 mm	Color-Black 25	Roads - Toes - Cross Section Surface Limit
C-ROAD-TOES-VCUT	6	Continuous	0.25 mm	Color-Black 25	Roads - Toes - Vertical Cutoff
C-ROAD-TOES-ZERO	6	Continuous	0.25 mm	Color-Black 25	Roads - Toes - Zero Point Between Cut/Fill
C-ROAD-TURN	6	Continuous	0.25 mm	Color-Black 25	Roads - Turn Calculations
C-ROAD-TURN-CARS	7	Continuous	0.35 mm	Black 35	Roads - Turn Calculations - Vehicle Outline
C-ROAD-TURN-FFEN	2	ALGN-PATH	0.35 mm	Black 35	Roads - Turn Calculations - Front Fender Path
C-ROAD-TURN-FLOG	3	Continuous	0.50 mm	Color-Black 50	Roads - Turn Calculations - Front Log End Path
C-ROAD-TURN-RLOG	4	Continuous	0.70 mm	Color-Black 70	Roads - Turn Calculations - Rear Log End Path
C-ROAD-TURN-ROVH	30	Continuous	0.25 mm	Black 25	Roads - Turn Calculations - Rear Overhang Path
C-ROAD-TURN-RWHL	1	Continuous	0.25 mm	Color-Black 25	Roads - Turn Calculations - Rear Wheel Path
C-RWAY-AREA-PATT	1	Continuous	0.25 mm	Color-Black 25	Right-of-way - Shading
C-RWAY-AREA-TEMP	7	Continuous	0.35 mm	Black 35	Right-of-way - Area Calculations
C-RWAY-BNDY	4	LOT-RW	0.70 mm	Color-Black 70	Right-of-way - Boundary
C-RWAY-CLGR-BNDY	3	CONST-CLGR	0.50 mm	Color-Black 50	Right-of-way - Clearing and Grubbing Boundary
C-RWAY-CLGR-TEMP	2	Continuous	0.35 mm	Black 35	Right-of-way - Clearing and Grubbing Area Calculations
C-RWAY-CLGR-TEXT	2	Continuous	0.35 mm	Black 35	Right-of-way - Clearing and Grubbing Text
C-RWAY-CORD-TEXT	2	Continuous	0.35 mm	Black 35	Right-of-way - Coordinate Text
C-RWAY-TEXT	2	Continuous	0.35 mm	Black 35	Right-of-way - Text
C-RWAY-TLCA	2	LOT-EA	0.35 mm	Black 35	Right-of-way - Temporary License for Construction
C-RWAY-TLCA-PATT	1	Continuous	0.25 mm	Color-Black 25	Right-of-way - Temporary License for Construction
C-RWAY-TLCA-TEMP	1	Continuous	0.25 mm	Color-Black 25	Right-of-way - Temporary License for Construction
C-RWAY-TLCA-TEXT	1	Continuous	0.25 mm	Color-Black 25	Right-of-way - Temporary License for Construction
C-RWAY-WAST	1	Continuous	0.25 mm	Color-Black 25	Right-of-way - Waste
C-SECT	6	Continuous	0.25 mm	Color-Black 25	Cross Sections - Base Layer
C-SECT-BARR-CONC	5	Continuous	0.25 mm	Color-Grey 60% 25	Cross Sections - Concrete Roadside Barrier
C-SECT-CURB	5	Continuous	0.25 mm	Color-Grey 60% 25	Cross Sections - Curb
C-SECT-CURB-DRAN	5	Continuous	0.25 mm	Color-Grey 60% 25	Cross Sections - Drainage Curb
C-SECT-DETL	1	Continuous	0.25 mm	Color-Black 25	Cross Sections - CAiCE Template Line Features
C-SECT-DETL-ANNO	6	Continuous	0.25 mm	Color-Black 25	Cross Sections - CAiCE Template Point Features
C-SECT-DIMS-MAJR	2	Continuous	0.35 mm	Black 35	Cross Sections - Major Dimensions (2.5mm)
C-SECT-DIMS-MINR	1	Continuous	0.25 mm	Color-Black 25	Cross Sections - Minor Dimensions (1.8mm)
C-SECT-EXST	36	Continuous	0.35 mm	Grey 60% 35	Cross Sections - Existing Ground
C-SECT-GRID-MAJR	253	Continuous	0.25 mm	Grey 60% 25	Cross Sections - Major Grid
C-SECT-GRID-MINR	251	Continuous	0.13 mm	Grey 40% 13	Cross Sections - Minor Grid
C-SECT-GUTR	5	Continuous	0.25 mm	Color-Grey 60% 25	Cross Sections - Curb and Gutter
C-SECT-MILL	5	Continuous	0.25 mm	Color-Grey 60% 25	Cross Sections - Milling Limits
C-SECT-PATT-MAJR	2	Continuous	0.35 mm	Black 35	Cross Sections - Major Hatching Area
C-SECT-PATT-MINR	1	Continuous	0.25 mm	Color-Black 25	Cross Sections - Minor Hatching Area
C-SECT-SKCH	1	Continuous	0.25 mm	Color-Black 25	Cross Sections - Sketching
C-SECT-STRP	30	CONST-STRIP	0.25 mm	Black 25	Cross Sections - Stripping
C-SECT-SURF	1	Continuous	0.25 mm	Color-Black 25	Cross Sections - Surfaces
C-SECT-SURV	253	Continuous	0.25 mm	Grey 60% 25	Cross Sections - Existing Features (Feature Code
C-SECT-TEXT	1	Continuous	0.25 mm	Color-Black 25	Cross Sections - New Features (Feature Code Labels)
C-SECT-TEXT-ALGN	3	Continuous	0.50 mm	Color-Black 50	Cross Sections - New Features (Centreline Labels)
C-SECT-TOPO	1	Continuous	0.25 mm	Color-Black 25	Cross Sections - Existing Topographic Features
C-SECT-TOPO-HOGF	1	CONST-HOGF	0.25 mm	Color-Black 25	Cross Sections - Hog Fuel (Construction)
C-SECT-TYPA	241	GEO-TYPE-A	0.25 mm	Black 25	Cross Sections - Type A (Solid Rock) Material Interface

MoT Section	1230	TAC Section	Not Applicable
-------------	------	-------------	----------------

NCS LAYER	COLOR	LINETYPE	WEIGHT	PLOT STYLE	DESCRIPTION (see notes at the bottom of the table)
C-SECT-TYPB	202	GEO-TYPE-B	0.25 mm	Grey 60% 25	Cross Sections - Type B (Over 50% Broken) Material
C-SECT-TYPC	165	GEO-TYPE-C	0.25 mm	Grey 60% 25	Cross Sections - Type C (Requires Ripping) Material
C-SECT-TYPD	5	Continuous	0.25 mm	Color-Grey 60% 25	Cross Sections - Type D Material Interface
C-SECT-VOLM-AFIL	1	Continuous	0.25 mm	Color-Black 25	Cross Sections - Volumes - Type-A Fill
C-SECT-VOLM-BFIL	241	Continuous	0.25 mm	Black 25	Cross Sections - Volumes - Type-B Fill
C-SECT-VOLM-CFIL	1	Continuous	0.25 mm	Color-Black 25	Cross Sections - Volumes - Type-C Fill
C-SECT-VOLM-DFIL	5	Continuous	0.25 mm	Color-Grey 60% 25	Cross Sections - Volumes - Type-D Fill
C-SECT-VOLM-WALL	165	Continuous	0.25 mm	Grey 60% 25	Cross Sections - Walls - CAiCE Volumes
C-SECT-WALL	2	Continuous	0.35 mm	Black 35	Cross Sections - Walls - CAiCE Surfaces
C-SECT-WALL-SECD	30	Continuous	0.25 mm	Black 25	Cross Sections - Walls - Secondary - CAiCE Surfaces
C-SECT-WAST	1	Continuous	0.25 mm	Color-Black 25	Cross Sections - Waste
C-SIGN	1	Continuous	0.25 mm	Color-Black 25	Signs - Base Layer
C-SIGN-IMAG	2	Continuous	0.35 mm	Black 35	Signs - Preview Image (GIF)
C-SIGN-TEXT	1	Continuous	0.25 mm	Color-Black 25	Signs - Text
C-SITE	1	Continuous	0.25 mm	Color-Black 25	General Site Features
C-SITE-CGRD	3	Continuous	0.50 mm	Color-Black 50	General Site Features - Cattle Guard
C-SITE-FENC	3	EXST-FENCE	0.50 mm	Color-Black 50	General Site Features - Fence
C-SITE-VEGE-TREE	3	Continuous	0.50 mm	Color-Black 50	Vegetation - Trees
C-SSWR	3	Continuous	0.50 mm	Color-Black 50	Sanitary Sewer - Base Layer
C-SSWR-FORC	3	Continuous	0.50 mm	Color-Black 50	Sanitary Sewer - Force Main
C-SSWR-FORC-PIPE	3	Continuous	0.50 mm	Color-Black 50	Sanitary Sewer - Force Main - Pipeline
C-SSWR-FORC-SYMB	1	Continuous	0.25 mm	Color-Black 25	Sanitary Sewer - Force Main - Symbols
C-SSWR-FORC-TEXT	3	Continuous	0.50 mm	Color-Black 50	Sanitary Sewer - Force Main - Text
C-SSWR-PIPE	3	UG-SAN	0.50 mm	Color-Black 50	Sanitary Sewer - Pipeline
C-SSWR-SYMB	1	Continuous	0.25 mm	Color-Black 25	Sanitary Sewer - Symbols
C-SSWR-TEXT	3	Continuous	0.50 mm	Color-Black 50	Sanitary Sewer - Text
C-STRC	3	Continuous	0.50 mm	Color-Black 50	Structures - Base Layer
C-STRC-BRDG	3	Continuous	0.50 mm	Color-Black 50	Structures - Bridge
C-STRC-BRDG-TEXT	1	Continuous	0.25 mm	Color-Black 25	Structures - Bridge - Text
C-STRC-MISC	1	Continuous	0.25 mm	Color-Black 25	Structures - Miscellaneous
C-STRC-WALL	3	Continuous	0.50 mm	Color-Black 50	Structures - Wall
C-STRC-WALL-BINW	3	WALL-DESIGN	0.50 mm	Color-Black 50	Structures - Wall - Bin
C-STRC-WALL-HEAD	3	WALL-DESIGN	0.50 mm	Color-Black 50	Structures - Wall - Head
C-STRC-WALL-RETN	3	WALL-DESIGN	0.50 mm	Color-Black 50	Structures - Wall - Retaining
C-STRC-WALL-TEXT	1	Continuous	0.25 mm	Color-Black 25	Structures - Wall - Text
C-STRC-WALL-WING	3	WALL-DESIGN	0.50 mm	Color-Black 50	Structures - Wall - Wing
C-STRM	3	Continuous	0.50 mm	Color-Black 50	Storm Sewer - Base Layer
C-STRM-PIPE	3	UG-DRAIN	0.50 mm	Color-Black 50	Storm Sewer - Pipeline
C-STRM-SYMB	1	Continuous	0.25 mm	Color-Black 25	Storm Sewer - Symbols
C-STRM-TEXT	3	Continuous	0.50 mm	Color-Black 50	Storm Sewer - Text
C-TOPO-BNDY-HOGF	1	CONST-HOGF	0.25 mm	Color-Black 25	Construction Survey - Hog Fuel Boundary
C-TOPO-BRKL	165	Continuous	0.25 mm	Grey 60% 25	Construction Survey - Change to Material
C-TOPO-OVBD	165	Continuous	0.25 mm	Grey 60% 25	Construction Survey - Overburden
C-TOPO-SPOT	6	Continuous	0.25 mm	Color-Black 25	Construction Survey - Spot Elevations
C-TOPO-SPOT-LINE	1	Continuous	0.25 mm	Color-Black 25	Construction Survey - Spot Elevations - Leaders and
C-TOPO-SPOT-TEXT	1	Continuous	0.25 mm	Color-Black 25	Construction Survey - Spot Elevations - Text
C-UTIL	1	Continuous	0.25 mm	Color-Black 25	Miscellaneous Utilities - Base Layer
C-UTIL-SGNL	6	Continuous	0.25 mm	Color-Black 25	Miscellaneous Utilities - Traffic Signals and Controllers
C-UTIL-SYMB	1	Continuous	0.25 mm	Color-Black 25	Miscellaneous Utilities - Symbols
C-UTIL-TEXT	2	Continuous	0.35 mm	Black 35	Miscellaneous Utilities - Text
C-UTIL-UGND	3	UG-MISC	0.50 mm	Color-Black 50	Miscellaneous Utilities - Underground
C-WATR	3	Continuous	0.50 mm	Color-Black 50	Water - Base Layer
C-WATR-PIPE	3	UG-WATER	0.50 mm	Color-Black 50	Water - Pipeline
C-WATR-SYMB	1	Continuous	0.25 mm	Color-Black 25	Water - Symbols
C-WATR-TEXT	3	Continuous	0.50 mm	Color-Black 50	Water - Text
G-ANNO	1	Continuous	0.25 mm	Color-Black 25	Annotation - Base Layer
G-ANNO-DETL	1	Continuous	0.25 mm	Color-Black 25	Annotation - Detail Blowups

MoT Section	1230	TAC Section	Not Applicable
-------------	------	-------------	----------------

NCS LAYER	COLOR	LINETYPE	WEIGHT	PLOT STYLE	DESCRIPTION (see notes at the bottom of the table)
G-ANNO-DETL-TEXT	1	Continuous	0.25 mm	Color-Black 25	Annotation - Detail Blowups - Text
G-ANNO-MATC	7	Continuous	0.35 mm	Black 35	Annotation - Match Lines
G-ANNO-MATC-TEXT	1	Continuous	0.25 mm	Color-Black 25	Annotation - Match Lines - Text
G-ANNO-NOTE	7	Continuous	0.35 mm	Black 35	Annotation - General Design Notes
G-ANNO-NRTH	7	Continuous	0.35 mm	Black 35	Annotation - North Arrow
G-ANNO-TEMP	7	Continuous	0.35 mm	Black 35	Annotation - Temporary Text
G-ANNO-TEXT	7	Continuous	0.35 mm	Black 35	Annotation - Text
G-ANNO-TTLB	7	Continuous	0.35 mm	Black 35	Annotation - Titleblock - Border and Frame
G-ANNO-TTLB-TEXT	1	Continuous	0.25 mm	Color-Black 25	Annotation - Titleblock - Text, Scales and Logos
G-ANNO-VFRM	1	Continuous	0.25 mm	Color-Black 25	Annotation - Sheet Layout View Frames
G-ANNO-VFRM-TEXT	1	Continuous	0.25 mm	Color-Black 25	Annotation - Sheet Layout View Frames Text
G-ANNO-VPRT	30	Continuous	0.25 mm	Black 25	Annotation - Viewports
V-ALGN	4	Continuous	0.70 mm	Color-Black 70	Alignment - Base Layer
V-ALGN-ANNO	1	Continuous	0.25 mm	Color-Black 25	Alignment - Minor Labels (Coordinates, Bearings)
V-ALGN-CURV	2	Continuous	0.35 mm	Black 35	Alignment - Curve and Spiral Data
V-ALGN-E100	4	Continuous	0.70 mm	Color-Black 70	Alignment - Specific Alignment
V-ALGN-E100-ANNO	1	Continuous	0.25 mm	Color-Black 25	Alignment - Minor Labels (Coordinates, Bearings)
V-ALGN-E100-CURV	2	Continuous	0.35 mm	Black 35	Alignment - Curve and Spiral Data
V-ALGN-E100-MAJR	2	Continuous	0.35 mm	Black 35	Alignment - 100m Major Tics and Text
V-ALGN-E100-MINR	1	Continuous	0.25 mm	Color-Black 25	Alignment - 20m Minor Tics
V-ALGN-E100-TEXT	2	Continuous	0.35 mm	Black 35	Alignment - Major Labels (POTs, Pls, Curve Points)
V-ALGN-LOCN	3	Continuous	0.50 mm	Color-Black 50	Alignment - Limit of Construction
V-ALGN-MAJR	2	Continuous	0.35 mm	Black 35	Alignment - 100m Major Tics and Text
V-ALGN-MINR	1	Continuous	0.25 mm	Color-Black 25	Alignment - 20m Minor Tics
V-ALGN-NOTE	2	Continuous	0.35 mm	Black 35	Alignment - Notations
V-ALGN-TEXT	2	Continuous	0.35 mm	Black 35	Alignment - Major Labels (POTs, Pls, Curve Points)
V-ANNO-GRID	1	Continuous	0.25 mm	Color-Black 25	Annotation - Grid
V-ANNO-GRID-NRTH	2	Continuous	0.35 mm	Black 35	Annotation - Grid - North Arrow
V-ANNO-GRID-TEXT	1	Continuous	0.25 mm	Color-Black 25	Annotation - Grid - Text
V-ANNO-NOTE	2	Continuous	0.35 mm	Black 35	Annotation - General Survey Notes
V-ANNO-TEMP	7	Continuous	0.35 mm	Black 35	Annotation - Temporary Working Layer
V-COMM	133	Continuous	0.25 mm	Black 25	Telephone and Cable - Base Layer
V-COMM-CNDT	133	UG-TEL	0.25 mm	Black 25	Telephone and Cable - Underground Conduit
V-COMM-SYMB	133	Continuous	0.25 mm	Black 25	Telephone and Cable - Symbols
V-COMM-TEXT	133	Continuous	0.25 mm	Black 25	Telephone and Cable - Text
V-CTRL	1	Continuous	0.25 mm	Color-Black 25	Control - Base Layer
V-CTRL-GEOD	1	Continuous	0.25 mm	Color-Black 25	Control - Control Monument - Geodetic
V-CTRL-MAJR	1	Continuous	0.25 mm	Color-Black 25	Control - Major (Benchmark)
V-CTRL-MINR	1	Continuous	0.25 mm	Color-Black 25	Control - Minor (Intermediate Detail Hub)
V-CTRL-REFP	1	Continuous	0.25 mm	Color-Black 25	Control - Reference Point
V-CTRL-STAN	6	Continuous	0.25 mm	Color-Black 25	Control - Station on Offset Line
V-DRAN	74	Continuous	0.25 mm	Black 25	Drainage - Base Layer
V-DRAN-DTCH	74	Continuous	0.25 mm	Black 25	Drainage - Ditch
V-DRAN-DTCH-CNTR	74	HYD-CNTR	0.25 mm	Black 25	Drainage - Ditch - Centre
V-DRAN-DTCH-EDGE	74	HYD-DITCH	0.25 mm	Black 25	Drainage - Ditch - Edge
V-DRAN-FLUM	74	Continuous	0.25 mm	Black 25	Drainage - Flume
V-DRAN-GUTR	74	Continuous	0.25 mm	Black 25	Drainage - Gutter
V-DRAN-PIPE	170	UG-PIPE	0.25 mm	Black 25	Drainage - Pipeline
V-DRAN-PIPE-PLST	170	UG-PLASTIC	0.25 mm	Black 25	Drainage - Pipeline - Plastic
V-DRAN-PIPE-SYMB	170	Continuous	0.25 mm	Black 25	Drainage - Pipeline - Symbols
V-DRAN-RRAP	74	CONST-RRAP	0.25 mm	Black 25	Drainage - Riprap
V-DRAN-SWAY	170	Continuous	0.25 mm	Black 25	Drainage - Spillway
V-IRRG	150	Continuous	0.25 mm	Color-Grey 60% 25	Irrigation - Base Layer
V-IRRG-SYMB	150	Continuous	0.25 mm	Color-Grey 60% 25	Irrigation - Symbols
V-IRRG-TEXT	150	Continuous	0.25 mm	Color-Grey 60% 25	Irrigation - Text
V-IRRG-UGND	150	UG-WATER	0.25 mm	Color-Grey 60% 25	Irrigation - Underground
V-NGAS	231	Continuous	0.25 mm	Black 25	Natural Gas - Base Layer

MoT Section	1230	TAC Section	Not Applicable
-------------	------	-------------	----------------

NCS LAYER	COLOR	LINETYPE	WEIGHT	PLOT STYLE	DESCRIPTION (see notes at the bottom of the table)
V-NGAS-PIPE	231	UG-GAS	0.25 mm	Black 25	Natural Gas - Pipeline
V-NGAS-SYMB	231	Continuous	0.25 mm	Black 25	Natural Gas - Symbols
V-NGAS-TEXT	231	Continuous	0.25 mm	Black 25	Natural Gas - Text
V-OIL~	10	Continuous	0.25 mm	Black 25	Oil - Base Layer
V-OIL~-SYMB	10	Continuous	0.25 mm	Black 25	Oil - Symbols
V-OIL~-TEXT	10	Continuous	0.25 mm	Black 25	Oil - Text
V-OIL~-UGND	10	UG-OIL	0.25 mm	Black 25	Oil - Underground
V-POWR	210	Continuous	0.25 mm	Black 25	Electrical Power - Base Layer
V-POWR-CNDT	210	UG-ELEC	0.25 mm	Black 25	Electrical Power - Underground Conduit
V-POWR-SYMB	210	Continuous	0.25 mm	Black 25	Electrical Power - Symbols
V-POWR-TEXT	210	Continuous	0.25 mm	Black 25	Electrical Power - Text
V-PROP	50	Continuous	0.25 mm	Black 25	Legal Properties - Base Layer
V-PROP-BNDY	2	Continuous	0.35 mm	Black 35	Legal Properties - Boundary
V-PROP-BNDY-INTL	4	LOT-IB	0.70 mm	Color-Black 70	Legal Properties - International Boundary
V-PROP-ESMT	2	LOT-EA	0.35 mm	Black 35	Legal Properties - Easement
V-PROP-FNIR	253	Continuous	0.25 mm	Grey 60% 25	Legal Properties - First Nations Indian Reserve
V-PROP-GAZT	32	LOT-GB	0.25 mm	Black 25	Legal Properties - Gazette
V-PROP-LINE	50	Continuous	0.25 mm	Black 25	Legal Properties - Lines (Working)
V-PROP-PINS	1	Continuous	0.25 mm	Color-Black 25	Legal Properties - Pins and Markers
V-PROP-PRCL	50	Continuous	0.25 mm	Black 25	Legal Properties - Parcels, Legal Subdivisions
V-PROP-QTRS	3	LOT-QS	0.50 mm	Color-Black 50	Legal Properties - Quarter Section
V-PROP-RNAM	83	Continuous	0.25 mm	Black 25	Legal Properties - Road Names
V-PROP-RWAY	2	Continuous	0.35 mm	Black 35	Legal Properties - Right-of-way
V-PROP-SECT	4	LOT-SL	0.70 mm	Color-Black 70	Legal Properties - Section Line or District Lot
V-PROP-TEXT	10	Continuous	0.25 mm	Black 25	Legal Properties - Text - Group, Section, District Lot,
V-PROP-TEXT-ADRS	53	Continuous	0.25 mm	Black 25	Legal Properties - Text - Owner Address
V-PROP-TEXT-OWNR	74	Continuous	0.25 mm	Black 25	Legal Properties - Text - Owner
V-PROP-TEXT-PID~	10	Continuous	0.25 mm	Black 25	Legal Properties - Text - PID
V-RAIL	10	EXST-RAIL	0.25 mm	Black 25	Railway - Base Layer
V-RAIL-GRVL	83	EXST-	0.25 mm	Black 25	Railway - Gravel (Ballast)
V-ROAD	22	Continuous	0.35 mm	Grey 60% 35	Roads - Base Layer
V-ROAD-ARRW	22	Continuous	0.35 mm	Grey 60% 35	Roads - Direction Arrow
V-ROAD-ASPH	22	Continuous	0.35 mm	Grey 60% 35	Roads - Asphalt
V-ROAD-BARM-CABL	8	BAR-CABLE	0.25 mm	Grey 60% 25	Roads - Cable Barrier
V-ROAD-BARM-CONC	8	BAR-MB	0.25 mm	Grey 60% 25	Roads - Concrete Median Barrier
V-ROAD-BARM-GRAL	8	Continuous	0.25 mm	Grey 60% 25	Roads - Guard Rail Median Barrier
V-ROAD-BARR-CONC	8	BAR-RB	0.25 mm	Grey 60% 25	Roads - Concrete Roadside Barrier
V-ROAD-BARR-GRAL	8	BAR-GUARD	0.25 mm	Grey 60% 25	Roads - Guard Rail Roadside Barrier
V-ROAD-CNTR	22	ALGN-CNTR	0.35 mm	Grey 60% 35	Roads - Centreline
V-ROAD-CNTR-LLIN	22	ALGN-CNTR	0.35 mm	Grey 60% 35	Roads - Centreline (Location Line)
V-ROAD-CURB-ASPH	22	Continuous	0.35 mm	Grey 60% 35	Roads - Asphalt Curb
V-ROAD-CURB-CONC	8	Continuous	0.25 mm	Grey 60% 25	Roads - Concrete Curb / Gutter
V-ROAD-DIRT	22	EXST-DIRTROAD	0.35 mm	Grey 60% 35	Roads - Dirt
V-ROAD-DRIV	22	Continuous	0.35 mm	Grey 60% 35	Roads - Driveway
V-ROAD-GRVL	22	EXST-GRAVEL	0.35 mm	Grey 60% 35	Roads - Gravel
V-ROAD-GRVL-SHLD	22	ALGN-SHLD	0.35 mm	Grey 60% 35	Roads - Gravel Shoulder
V-ROAD-MRKG	53	Continuous	0.25 mm	Black 25	Roads - Pavement Marking
V-ROAD-MRKG-ARRW	53	Continuous	0.25 mm	Black 25	Roads - Pavement Marking - Direction Arrow
V-ROAD-MRKG-BRKN	53	ALGN-BWL	0.25 mm	Black 25	Roads - Pavement Marking - Broken White Line - Rural
V-ROAD-MRKG-DECL	53	ALGN-DECL	0.25 mm	Black 25	Roads - Pavement Marking - Deceleration Lane
V-ROAD-MRKG-URPL	53	ALGN-BWL-URB	0.25 mm	Black 25	Roads - Pavement Marking - Broken White Line -
V-ROAD-MRKG-WHIT	53	Continuous	0.25 mm	Black 25	Roads - Pavement Marking - White Line
V-ROAD-MRKG-XWLK	53	Continuous	0.25 mm	Black 25	Roads - Pavement Marking - Crosswalk
V-ROAD-MRKG-YELD	53	ALGN-DYL	0.25 mm	Black 25	Roads - Pavement Marking - Double Yellow Line
V-ROAD-MRKG-YELO	53	ALGN-YL	0.25 mm	Black 25	Roads - Pavement Marking - Yellow Line
V-ROAD-PVMT	22	Continuous	0.35 mm	Grey 60% 35	Roads - Pavement
V-ROAD-PVMT-CRCK	22	TOPO-CRACK	0.35 mm	Grey 60% 35	Roads - Pavement - Crack

MoT Section	1230	TAC Section	Not Applicable
-------------	------	-------------	----------------

NCS LAYER	COLOR	LINETYPE	WEIGHT	PLOT STYLE	DESCRIPTION (see notes at the bottom of the table)
V-ROAD-PVMT-EDGE	22	Continuous	0.35 mm	Grey 60% 35	Roads - Edge of Pavement
V-ROAD-RAIS	22	Continuous	0.35 mm	Grey 60% 35	Roads - Raised Island
V-ROAD-REST	22	EXST-RESTAREA	0.35 mm	Grey 60% 35	Roads - Rest Area
V-ROAD-ROAD	22	EXST-ROAD	0.35 mm	Grey 60% 35	Roads - Road
V-ROAD-SCAL	22	Continuous	0.35 mm	Grey 60% 35	Roads - Weighscale
V-ROAD-SHLD	22	ALGN-SHLD	0.35 mm	Grey 60% 35	Roads - Shoulder Left/Right
V-ROAD-SWLK	22	Continuous	0.35 mm	Grey 60% 35	Roads - Sidewalk
V-ROAD-TOES	22	EXST-TOE	0.35 mm	Grey 60% 35	Roads - Toes
V-ROAD-XWLK	53	Continuous	0.25 mm	Black 25	Roads - Crosswalk
V-SIGN	8	Continuous	0.25 mm	Grey 60% 25	Signs - Base Layer
V-SIGN-TEXT	251	Continuous	0.13 mm	Grey 40% 13	Signs - Text
V-SITE	8	Continuous	0.25 mm	Grey 60% 25	General Site Features - Base Layer
V-SITE-ARCH	83	Continuous	0.25 mm	Black 25	General Site Features - Archaeological Site
V-SITE-BLDG	83	Continuous	0.25 mm	Black 25	General Site Features - Buildings
V-SITE-CGRD	8	Continuous	0.25 mm	Grey 60% 25	General Site Features - Cattle Guard
V-SITE-FENC	8	EXST-FENCE	0.25 mm	Grey 60% 25	General Site Features - Fence
V-SITE-GRVL	8	EXST-GRAVEL	0.25 mm	Grey 60% 25	General Site Features - Gravel
V-SITE-HOGF	8	CONST-HOGF	0.25 mm	Grey 60% 25	General Site Features - Hog Fuel
V-SITE-MISC	8	Continuous	0.25 mm	Grey 60% 25	General Site Features - Miscellaneous
V-SITE-VEGE	116	EXST-VEG	0.25 mm	Grey 60% 25	Vegetation - Base Layer
V-SITE-VEGE-BUSH	116	EXST-TREELINE	0.25 mm	Grey 60% 25	Vegetation - Bushes and Hedges
V-SITE-VEGE-CLGR	116	CONST-CLGR	0.25 mm	Grey 60% 25	Vegetation - Clearing and Grubbing
V-SITE-VEGE-PLNT	116	Continuous	0.25 mm	Grey 60% 25	Vegetation - Plants
V-SITE-VEGE-TREE	116	Continuous	0.25 mm	Grey 60% 25	Vegetation - Trees
V-SITE-VEGE-TROW	116	EXST-TREELINE	0.25 mm	Grey 60% 25	Vegetation - Tree Lines
V-SITE-VEGE-TURF	116	EXST-VEG	0.25 mm	Grey 60% 25	Vegetation - Lawn
V-SSWR	32	Continuous	0.25 mm	Black 25	Sanitary Sewer - Base Layer
V-SSWR-FORC	32	Continuous	0.25 mm	Black 25	Sanitary Sewer - Force Main
V-SSWR-FORC-PIPE	32	Continuous	0.25 mm	Black 25	Sanitary Sewer - Force Main - Pipeline
V-SSWR-FORC-SYMB	32	Continuous	0.25 mm	Black 25	Sanitary Sewer - Force Main - Symbols
V-SSWR-FORC-TEXT	32	Continuous	0.25 mm	Black 25	Sanitary Sewer - Force Main - Text
V-SSWR-PIPE	32	UG-SAN	0.25 mm	Black 25	Sanitary Sewer - Pipeline
V-SSWR-SYMB	32	Continuous	0.25 mm	Black 25	Sanitary Sewer - Symbols
V-SSWR-TEXT	32	Continuous	0.25 mm	Black 25	Sanitary Sewer - Text
V-STRC	11	Continuous	0.25 mm	Black 25	Structures - Base Layer
V-STRC-BRDG	11	Continuous	0.25 mm	Black 25	Structures - Bridge
V-STRC-SITE	11	Continuous	0.25 mm	Black 25	Structures - General Site Features
V-STRC-WALL	11	Continuous	0.25 mm	Black 25	Structures - Wall
V-STRC-WALL-BINW	11	WALL-EXIST	0.25 mm	Black 25	Structures - Wall - Bin
V-STRC-WALL-HEAD	11	WALL-EXIST	0.25 mm	Black 25	Structures - Wall - Head
V-STRC-WALL-RETN	11	WALL-EXIST	0.25 mm	Black 25	Structures - Wall - Retaining
V-STRC-WALL-WING	11	WALL-EXIST	0.25 mm	Black 25	Structures - Wall - Wing
V-STRM	90	Continuous	0.25 mm	Black 25	Storm Sewer - Base Layer
V-STRM-PIPE	90	UG-DRAIN	0.25 mm	Black 25	Storm Sewer - Pipeline
V-STRM-SYMB	90	Continuous	0.25 mm	Black 25	Storm Sewer - Symbols
V-STRM-TEXT	90	Continuous	0.25 mm	Black 25	Storm Sewer - Text
V-SURV-BNDY	253	EXST-TOE	0.25 mm	Grey 60% 25	General Survey - Survey Boundary
V-SURV-SPOT	135	Continuous	0.25 mm	Black 25	General Survey - Spot Elevations
V-SURV-SPOT-<KCFC>	135	Continuous	0.25 mm	Black 25	General Survey - Spot Elevations - Feature Code
V-TOPO	155	Continuous	0.25 mm	Grey 60% 25	Topographic - Base Layer
V-TOPO-BERM	155	CONST-BERM	0.25 mm	Grey 60% 25	Topographic - Berm in Cut or Fill
V-TOPO-BOTB	155	TOPO-BSLP	0.25 mm	Grey 60% 25	Topographic - Bottom of Slope / Bank
V-TOPO-BRKL	155	Continuous	0.25 mm	Grey 60% 25	Topographic - Break in Ground Line
V-TOPO-CRCK	155	TOPO-CRACK	0.25 mm	Grey 60% 25	Topographic - Ground Crack
V-TOPO-MAJR	253	Continuous	0.25 mm	Grey 60% 25	Topographic - Major Contours
V-TOPO-MINR	251	Continuous	0.13 mm	Grey 40% 13	Topographic - Minor Contours
V-TOPO-MISC	2	Continuous	0.35 mm	Black 35	Topographic - Miscellaneous (Unidentified)

MoT Section	1230	TAC Section	Not Applicable
-------------	------	-------------	----------------

NCS LAYER	COLOR	LINETYPE	WEIGHT	PLOT STYLE	DESCRIPTION (see notes at the bottom of the table)
V-TOPO-PROF	2	Continuous	0.35 mm	Black 35	Topographic - Terrain Profile
V-TOPO-ROCK-BRCK	155	TOPO-TALUS	0.25 mm	Grey 60% 25	Topographic - Base of Rock
V-TOPO-ROCK-BRKL	155	Continuous	0.25 mm	Grey 60% 25	Topographic - Break Lines
V-TOPO-ROCK-BRKN	155	TOPO-TALUS	0.25 mm	Grey 60% 25	Topographic - Broken Rock
V-TOPO-ROCK-HRZA	2	TOPO-HORIZON-A	0.35 mm	Black 35	Topographic - Type A Horizon
V-TOPO-ROCK-LOOS	155	TOPO-TALUS	0.25 mm	Grey 60% 25	Topographic - Loose Rock
V-TOPO-ROCK-MISC	155	Continuous	0.25 mm	Grey 60% 25	Topographic - Other Solid Rock
V-TOPO-ROCK-OVBK	155	Continuous	0.25 mm	Grey 60% 25	Topographic - Overbreak
V-TOPO-ROCK-SOLD	155	TOPO-ROCK	0.25 mm	Grey 60% 25	Topographic - Solid Rock
V-TOPO-ROCK-TRCK	155	TOPO-ROCK	0.25 mm	Grey 60% 25	Topographic - Top of Rock
V-TOPO-SAND	155	TOPO-SAND	0.25 mm	Grey 60% 25	Topographic - Sand
V-TOPO-SLGH	155	TOPO-SLIDE	0.25 mm	Grey 60% 25	Topographic - Slough / Talus
V-TOPO-SPCL	251	Continuous	0.13 mm	Grey 40% 13	Topographic - Special Contours
V-TOPO-TALS	155	TOPO-TALUS	0.25 mm	Grey 60% 25	Topographic - Talus
V-TOPO-TOPB	155	TOPO-TSLP	0.25 mm	Grey 60% 25	Topographic - Top of Slope / Bank
V-TOPO-TRAL	155	TOPO-TRAIL	0.25 mm	Grey 60% 25	Topographic - Trail (Mapping Requirement)
V-TOPO-WAST	155	CONST-WASTE	0.25 mm	Grey 60% 25	Topographic - Waste
V-TOPO-WATR-CNTR	5	HYD-CNTR	0.25 mm	Color-Grey 60% 25	Topographic - Water - Narrow Water (Creek, Stream)
V-TOPO-WATR-EDGE	5	HYD-EW	0.25 mm	Color-Grey 60% 25	Topographic - Water - Wide Water Edge
V-TOPO-WATR-EHWM	5	HYD-HWE	0.25 mm	Color-Grey 60% 25	Topographic - Water - Extreme High Water Mark
V-TOPO-WATR-FDPL	5	Continuous	0.25 mm	Color-Grey 60% 25	Topographic - Water - Flood Plain (High Water Mark)
V-TOPO-WATR-HIGH	5	HYD-HW	0.25 mm	Color-Grey 60% 25	Topographic - Water - High Water Mark
V-TOPO-WATR-OBJT	155	Continuous	0.25 mm	Grey 60% 25	Topographic - Water - Objects (Ice, Log Jam)
V-TOPO-WATR-SEEP	5	HYD-SEEP	0.25 mm	Color-Grey 60% 25	Topographic - Water - Seepage
V-TOPO-WATR-STRE	5	HYD-CNTR	0.25 mm	Color-Grey 60% 25	Topographic - Water - Stream
V-TOPO-WETL	155	TOPO-MARSH	0.25 mm	Grey 60% 25	Topographic - Wetlands (Swamp / Marsh)
V-UTIL	200	Continuous	0.25 mm	Grey 60% 25	Miscellaneous Utilities - Base Layer
V-UTIL-SYMB	200	Continuous	0.25 mm	Grey 60% 25	Miscellaneous Utilities - Symbols
V-UTIL-TEXT	200	Continuous	0.25 mm	Grey 60% 25	Miscellaneous Utilities - Text
V-UTIL-UGND	200	UG-MISC	0.25 mm	Grey 60% 25	Miscellaneous Utilities - Underground
V-WATR	150	Continuous	0.25 mm	Color-Grey 60% 25	Water - Base Layer
V-WATR-PIPE	150	UG-WATER	0.25 mm	Color-Grey 60% 25	Water - Pipeline
V-WATR-SYMB	150	Continuous	0.25 mm	Color-Grey 60% 25	Water - Symbols
V-WATR-TEXT	150	Continuous	0.25 mm	Color-Grey 60% 25	Water - Text

Shaded rows are example layer names only and are used to create unique layers for specific feature codes or alignments as needed. The alignment name is added as a minor group code and may be longer than the allowed 4 character limit. In the case of a feature code used as a minor group code, tilde characters (~) are to be added as required to fill out the code to 4 characters.

The current Highway Engineering AutoCAD Drafting Standards download (see [Section 1240](#)) contains a spreadsheet and an AutoCAD DWT template. Both the spreadsheet and the template will always contain the latest list of layers along with a complete description for each layer. The layer names and descriptions can be found in the "NCS Layers" worksheet and the AutoCAD **Layer Properties Manager** dialog. Please note that the above list may be updated only occasionally and page size constraints limit the layer descriptions in some cases.

MoT Section	1240	TAC Section	Not Applicable
-------------	------	-------------	----------------

1240 AUTOCAD STANDARDS

1240.01 INTRODUCTION

This section details a number of general AutoCAD techniques and property settings related to the BC Ministry of Transportation and Infrastructure, Highway Engineering, CAD standards.

1240.02 REQUIRED FILES

For consultants, the ministry Highway Engineering AutoCAD Drafting Standards may be downloaded from the following web page:

<http://www.th.gov.bc.ca/AutoCAD>

1240.03 BYLAYER PROPERTIES

General properties assigned to all AutoCAD entities include: Layer, Colour, Linetype, Lineweight, Plot Style and Transparency.

The ministry has now adopted a stricter ByLayer standard which allows the layer table to control the appearance of all drawing entities.

Each layer is assigned a colour, linetype, lineweight, plot style and transparency. The associated drawing entity properties should always be assigned the value "ByLayer".

Object Properties Assignment	
Layer	Select layer from list
Colour	ByLayer
Linetype	ByLayer
Lineweight	ByLayer
Plot Style	ByLayer
Transparency	ByLayer

Exceptions for Blocks

Multiple colour block inserts such as the standard titleblock contain several colours and lineweights.

The internal block entities do not require separate layer on/off control and are therefore assigned specific colours, lineweights and plot styles.

Other Exceptions

Deviations from this standard should be an exception and not the rule.

As the standard evolves, certain items may be listed as common exceptions. Requirements for exceptions should be reported to the ministry.

MoT Section	1240	TAC Section	Not Applicable
-------------	------	-------------	----------------

1240.04 TEXT STYLES

Four text styles are defined in the standard drawing template:

Standard	Font = RomanS.shx, Height = 0
Arial	Font = Arial, Height = 0
ArialBold	Font = Arial (Bold), Height = 0
BC Symbol	Font = Arial, Height = 0

The **Arial** style should be used where text weight is required for emphasis. The **Arial** font proportionally increases in weight as the height increases, the line weight of the plot style is not a factor. This significantly reduces the need for multi-coloured text and therefore the need for extra layers or individually coloured text.

The bold **Arial** style may be used where additional emphasis is required.

The Standard style (**RomanS.shx**) may be used for text heights ≤ 2.5 mm where on-screen clarity of the text is desired or performance is improved with a larger number of text entities (e.g. grid point or contour labels).

The **BC Symbol** style is used by most of the standard symbols (see [Section 1250](#)). The use of a separate style name allows for a quick change from the **Arial** font to **RomanS.shx** without the need to edit all of the individual blocks.

Use of the ministry **Highways.shx** font is no longer permitted and this font file is supplied only in order to support existing drawings.

1240.05 TEXT SCALING AND STANDARD HEIGHTS

AutoCAD's annotation scaling features should be used as opposed to creating separate text layers for labelling at multiple scales. The text justification position (e.g. Center) should be set to avoid unwanted label movement due to annotation scaling. All text heights in this section are specified for 1:1000 scale plots.

Standard text heights include 1.8 mm, 2.5 mm, 3.5 mm, 5.0 mm and 7.0 mm. The **Arial** styles/font will adjust the weight of the text automatically depending on the height and the plot style line weight will be ignored. Therefore there are no longer specific colors/weights assigned to the various standard text heights.

However, if the **RomanS.shx** font is used for 1.8 mm text, the plot style should assign a 0.18 mm or 0.25 mm line weight. A 0.25 mm weight should be used for 2.5 mm text. **RomanS.shx** should not be used for 3.5 mm, 5.0 mm or 7.0 mm text.

Refer to the following sections and the sample drawings in [Section 1220](#) for information on heights for specific types of text.

Adjusting Text Heights for the Arial Font

The heights listed in this section are the standard text heights traditionally used with the **RomanS.shx** font. As the **Arial** font may not be as readable at these sizes (especially on 11x17 plots), it is permissible to increase the standard text heights as shown.

Standard Text Heights (RomanS.shx) (1:1000)	Alternate Text Heights for Arial Font (1:1000)
1.8 mm	2.1 mm
2.5 mm	3.0 mm
3.5 mm	4.0 mm
5.0 mm	6.0 mm
7.0 mm	8.5 mm
10.0 mm	12.0 mm

MoT Section	1240		TAC Section	Not Applicable
-------------	------	--	-------------	----------------

1240.06 GENERAL ANNOTATION – TEXT HEIGHTS

Description	Layer	Height (1:1000)
Miscellaneous Notes	G-ANNO-NOTE, G-ANNO-TEXT	Varies
Titleblock - Ministry Name	G-ANNO-TTLB-TEXT	3.7
Titleblock - Branch/Office Name	G-ANNO-TTLB-TEXT	3.0
Titleblock - Name/Type of Sheet	G-ANNO-TTLB-TEXT	5.0
Titleblock - Highway/Project Description	G-ANNO-TTLB-TEXT	3.5
Titleblock - Stationing, Scale for Sheet	G-ANNO-TTLB-TEXT	2.5
Titleblock - File, Project, Region, Drawing Number, Revision	G-ANNO-TTLB-TEXT	3.5
Titleblock - Revision Details, Signature Date	G-ANNO-TTLB-TEXT	2.0
Titleblock - CAD Filename/Date, Designed, Drawn, QA, QC	G-ANNO-TTLB-TEXT	1.8

1240.07 EXISTING PLAN DETAIL – TEXT HEIGHTS

Description	Layer	Height (1:1000)
Grid Point (N/E labels)	V-ANNO-GRID	1.8
Lot Description	V-PROP-TEXT	3.5
Plan Number	V-PROP-TEXT	5.0
District Lot Description	V-PROP-TEXT	7.0/10.0
Quarter Section Description	V-PROP-TEXT	7.0 Bold
Municipal Description	V-PROP-TEXT	5.0
Range Description	V-PROP-TEXT	5.0
Township Description	V-PROP-TEXT	3.5
Contours	V-TOPO-MAJR	2.5 Fine/Grey
Instrumentation	B-ANNO-TEXT	2.5 Bold
Sign Information	V-SIGNS	Varies
Spot Elevations	V-SURV-SPOT	1.8

MoT Section	1240		TAC Section	Not Applicable
-------------	------	--	-------------	----------------

1240.08 PROPOSED PLAN DETAIL – TEXT HEIGHTS

Description	Layer	Height (1:1000)
Culvert Note	C-DRAN-TEXT	2.5 Italic
Catch Basin Notes	C-DRAN-TEXT	2.5
Drainage Notes	C-DRAN-TEXT	2.5
Insets - Titles	G-ANNO-DETL	Varies
Insets - General	G-ANNO-DETL-TEXT	Varies
Curve Geometry/Points (Secondary Roads, Access, Quadrants)	C-ALGN-NOTE	2.5
Tangent Azimuth, Distance	C-ALGN-ANNO	2.5
100m Stations	C-ALGN-MAJR	2.5 Bold
POTs , POSTs, etc.	C-ALGN-TEXT	2.5
PI, BC, EC, TS, SC, CC, CS, ST, etc.	C-ALGN-TEXT	3.5
PI Boxed Coordinates	C-ALGN-ANNO	1.8
Alignment Curve Data	C-ALGN-CURV	3.5
Limits of Construction (Main Line)	C-ALGN-LOCN	5.0
Limits of Construction (Secondary Line)	C-ALGN-LOCN	3.5
Abutment Stations	C-ALGN-ANNO	2.5 Bold
Alignment Text	C-ALGN-NOTE	2.5
Lane Width	C-ALGN-NOTE	Varies
Notation Paint Lines	C-ALGN-NOTE	2.5
Notation Pavement Edge	C-ALGN-NOTE	2.5
Notation Shoulder	C-ALGN-NOTE	2.5
Notation Begin/End Taper	C-ALGN-NOTE	2.5
Notation Begin/End Barrier	C-ALGN-NOTE	2.5
Design Notes – Boxed Notes (Remove, Abandon, etc.)	G-ANNO-NOTE	Varies
Design Notes – Other	G-ANNO-NOTE	Varies
Match Lines	G-ANNO-NOTE	1.8
Construction Notes	G-ANNO-NOTE	2.5/3.5
Construction Notes Title	G-ANNO-NOTE	Varies
Offset/Station to Proposed Right-of-Way	V-PROP-RWAY	3.5
Right-of-Way Boxed Areas	V-PROP-RWAY	2.5 Bold
Right-of-Way Sheet Summary (R/W Required, etc.)	V-PROP-RWAY	2.5 Bold
Offset/Station Clearing and Grubbing	V-PROP-RWAY	2.5
Clearing and Grubbing Areas	V-PROP-RWAY	2.5 Bold
Limits (Clearing and Grubbing Notes)	V-PROP-RWAY	2.5
Offset/Station to Disposal Area	V-PROP-RWAY	2.5
Summary (Clearing and Grubbing)	V-PROP-RWAY	2.5 Bold
Sign Symbol Text	C-SIGN-TEXT	2.5
Sign Box Title (Summary)	C-SIGN-TEXT	3.5
Sign Box Text (Summary)	C-SIGN-TEXT	2.5
Spot Elevation Text	C-TOPO-SPOT	1.8 or 2.5
Bridge Text	C-STRC-BRDG	2.5
Cut and Fill Notation	C-ROAD-TOES	2.5

MoT Section	1240		TAC Section	Not Applicable
-------------	------	--	-------------	----------------

1240.09 TYPICAL CROSS SECTIONS – TEXT HEIGHTS

Description	Layer	Height (1:1000)
Section Title	C-SECT	5
Section Subtitle	C-SECT	3.5
Dimensions	C-SECT	2.5
Descriptive Text	C-SECT	2.5
Notes	G-ANNO-NOTE	Varies
Insets - Titles	G-ANNO-DETL	Varies
Insets - General	G-ANNO-DETL-TEXT	Varies

1240.10 CROSS SECTIONS – TEXT HEIGHTS

Description	Layer	Height (1:1000)
Grid Labels	C-SECT-GRID-MAJR	2.5
Stationing	G-ANNO-NOTE	7
Elevations	G-ANNO-NOTE	5
Notations	G-ANNO-NOTE	2.5

1240.11 PROFILES – TEXT HEIGHTS

Description	Layer	Height (1:1000)
L.B.M. Description	C-PROF-GRID-LABL	2.5 Bold
Elevations and Stations	C-PROF-GRID-LABL	3.5
Quantities	C-PROF-QUAN	3.5
Top Sheet Files (Excavation, Embankment, etc.)	C-PROF-QUAN	3.5
Existing Utility Information	C-PROF-EXST-UTIL	2.5
Culvert Description	C-PROF-DRAN	2.5 Italic
Ditching Description	C-PROF-DRAN	2.5
Horizontal Alignment Data	C-PROF-HORZ-TEXT	2.5
Construction Notes	G-ANNO-NOTE	2.5
Design Speed	G-ANNO-NOTE	5
Notes	G-ANNO-NOTE	3.5 Bold
Profile Data	C-PROF-ALGN-TEXT	3.5
Limit of Construction	C-PROF-HORZ-LOCN	5
Insets - Titles	G-ANNO-DETL	Varies
Insets - General	G-ANNO-DETL-TEXT	Varies

MoT Section	1240		TAC Section	Not Applicable
-------------	------	--	-------------	----------------

1240.12 PLOT STYLES

Named Plot Styles (STB Drawings)

The ministry now uses named plot styles (STB) as opposed to colour-dependant plot styles (CTB).

The setting that controls the plot style type (CTB or STB) is stored in the drawing file (DWG).

The ministry drawing template (DWT), containing the layers, linetypes and symbols as described in this chapter, uses named plot styles (STB). When this template is used as the basis for a new drawing, only STB files will be visible in the plot dialog.

Choosing STB/CTB Files for Printing

If a named plot style drawing is active in AutoCAD, the PLOT command dialog will show a list of STB files. If an older colour-dependant drawing is active, the dialog will show a list of CTB files.

Converting Drawings

Drawings may be converted from CTB to the new STB standard or vice versa via the CONVERTPSTYLES command. A file named **BC MoT STB Conversion.stb** is provided for this purpose.

The conversion is not recommended due to the amount of work involved and the potential for errors. Each item in the drawing would have to be checked to ensure the correct layer, colour, linetype and plot style were assigned. This may include internal block entities.

STB and CTB Comparison

CTB files contain a list of the 255 AutoCAD colours and a plotting configuration for each. The CTB file defines how the entities using each colour will plot.

STB files contain a shorter list of plot style names and a plotting configuration for each. The STB file defines how the entities assigned to a particular plot style name will plot. As with CTB files, one STB can be used to plot everything as black/grey while another could be created to plot in colour with half-width line weights.

Colours and plot style names are usually assigned per layer in modern drawings and that is the standard for ministry drawings.

Named Plot Style Details

A descriptive plot style name from a fairly short list is assigned to each layer. The layer table is the primary control for plotting style.

All model and paper space entities have their Plot Style name set to ByLayer.

One feature of the STB system is that layers or entities may be assigned any plot style regardless of the display colour. One yellow layer may be assigned to plot black while another yellow layer may be assigned to plot yellow. This also applies to entities.

For consistency and ease of use, the default plot styles ensure that all layers of a certain color will print with the same plot style. This allows the CAD operator to easily correlate the screen colour to the plot colour in the same way that the CTB system used to work.

Overriding Plot Styles

In certain cases, such as a presentation drawing, it may be desirable to plot most of the drawing in the standard black/grey shades and highlight a few items in color.

MoT Section	1240		TAC Section	Not Applicable
-------------	------	--	-------------	----------------

It is permissible to alter the default plot style for an individual layer or entity to accomplish this. For example, if the C-ALGN layer plot style is changed from **Color-Black 70** to **Color 70** then the main alignment will show up in CYAN even though the **BC MoT Black Grey.stb** file is used.

One method for doing this would be to create a new layout and assign the plot style in the **VP Plot Style** column. This avoids altering the main **Plot Style** for that particular layer. The **VP Plot Style** column is only available in AutoCAD 2010 and newer versions.

BC MoT Plot Style Tables

There are four standard STB files that control how each plot style name is interpreted. The STB file is assigned to the layout in the plot dialog. Multiple layouts may be created for color, black, full-size or half-size plots.

Any of these tables may be assigned to the drawing in the model tab with the PLOTSTYLE command or via the Properties palette. All STB files must contain the same plot style names.

BC MoT Black Grey.stb – full size black/grey plots

BC MoT ½ Size Black Grey.stb – half size black/grey

BC MoT Color.stb – full size colour plots

BC MoT ½ Size Color.stb – half size colour plots

BC MoT Plot Style Names

The ministry has defined 30 plot style names. The examples below demonstrate how the names are interpreted. The last number (25, 35, 50, 70) always indicates the line weight on a full size plot: 25 = 0.25 mm, 35 = 0.35 mm. A weight of 25 is 0.25 mm when using the full size STB files and 0.13 mm for the half size STB files.

Black 25

Layers or entities using this plot style will print black no matter which STB file is selected. The weight will be 0.25 mm or 0.13 mm depending on which STB file is attached (full size or ½ size).

Color-Black 50

The on-screen colour will be used for a colour STB and black will be used for a black/grey STB. The weight will be 0.50 mm or 0.25 mm.

Color-Grey 60% 35

Same as above except 60% grey for a black/grey STB file. The weight will be 0.35 mm or 0.18 mm.

Color-Greyscale 50

The on-screen colour will be used for a colour STB and a greyscale equivalent will be used for a black/grey STB. The weight will be 0.50 mm or 0.25 mm.

Color 70

The “Color 70” plot style will always print using the on-screen colour. This is an example of a plot style that could be used to add some colour to an otherwise black/grey plot. In other words, if a black/grey STB file is attached, this style will override and provide colour output.

Plotting Results

The choice of STB file in the PLOT dialog (and the definitions inside the file) and the selection of plot style name in the layer dialog (and occasionally per entity) together determine the colour and weight of the plotted output.

MoT Section	1240		TAC Section	Not Applicable
-------------	------	--	-------------	----------------

1240.13 SCREENING EXISTING DETAIL

Changing the plot style of existing detail layers to print them in a shade of grey will produce a screening effect that ensures the proposed detail is the most prominent while providing legible existing detail.

Existing detail should be contained in separate drawings and externally referenced into the design drawings both for drawing integrity and for performance reasons. With this method, the plot style of the existing detail x-ref layers may be altered to force the detail to print in a shade of grey. This will not affect the default plot style for these layers as stored in the external drawing.

Newer versions of AutoCAD allow the plot style of a layer to be adjusted separately for each layout viewport. With this capability, the existing detail can remain integrated into the design drawing if necessary. The default plot style for these layers will be displayed in the main **Plot Style** column of the layer table and the printed plot styles can be adjusted for screening within the individual layouts using the **VP Plot Style** column.

MoT Section	1250	TAC Section	Not Applicable
-------------	------	-------------	----------------

1250 AUTOCAD SYMBOLS

1250.01 INTRODUCTION

The Ministry Engineering Branch has developed standard symbols to represent existing features as picked up in a field survey, as well as design features that must be shown on contract drawings. This includes the usual assortment of notes, bar scales, arrows, etc.

Where appropriate, the survey symbols have been selected from standards set by the BC Surveyor General's Office.

A drawing template containing the symbols and other supplied files are available for consultant download as described in [Section 1240](#).

The symbols have been grouped into categories in the following subsections:

Survey Symbols	1250.02
Aerial Utilities	1250.03
Detail	1250.04
Drainage	1250.05
Proposed Drainage	1250.06
Underground	1250.07
Electrical	1250.08
Meters	1250.09
Road Signs	1250.10
Lane Arrows	1250.11
Miscellaneous Arrows	1250.12
Roundabout Lane Arrows	1250.13
Construction Notes	1250.14
Miscellaneous Notes	1250.15
Geotech Legends	1250.16
Geotech General	1250.17
Geotech Pit Development	1250.18
Titleblocks and Frames	1250.19

Block Definitions

All **internal entities** are assigned **ByBlock** attributes with some exceptions noted below.

Block **insertions** are to be assigned standard **ByLayer** properties (see [Section 1240.02](#)) and will take on the properties of the assigned layer.

Non-Standard Blocks

A number of the supplied blocks require multiple line weights. The complete list of multi-colour blocks is as follows:

- Titleblocks: frame, titleblocks
- Ministry Logos: bclogo
- Provincial Logos: motlogo, motlogo_color
- Front Pages: frontpg, frontpg_color
- Regional/District Maps: bcmaps
- Geotechnical Legends: leg-soil, leg-pit, leg-th
- Geotechnical Keymap: keymap

The internal entities of these blocks may be assigned specific layers, colours and plot styles.

Blocks with Attributes and Text

A number of blocks include adjustable attributes:

PROFNOTE, DESSPEED, SPLATE, PIEZMTR, SLOPE, TESTHOLA, TESTPITA, FEATURE, HUB, TITLEBLOCKS

Text in the titleblock, legend and note blocks use the **Arial** text style.

All other symbols containing text or attributes are assigned a text style named **BC Symbol**. The default font for this style is Arial. This may be adjusted to RomanS.shx if necessary.

Dynamic Blocks

The following dynamic blocks have been created:















TITLEBLOCKS contains all of the standard titleblocks, use the grip or the Properties palette to select the type (standard, low profile horizontal, ...).

SCALES includes all standard scales with an insertion point that can be attached to a vertex endpoint on the TITLEBLOCKS block. The orientation may be adjusted to support the vertical titleblock.







BCLOGO and BCMAPS are similar to SCALES and include options for a color or black-grey logo and various regional and district maps.

MoT Section	1250	TAC Section	Not Applicable
-------------	------	-------------	----------------

1250.02 SURVEY SYMBOLS















Symbol	Name	Feature	Description	Layer
	INDEFELV	IE	Indefinite Elevation <i>mapping requirement</i>	V-TOPO-MISC
	MSRD-PNT	PM	Unmarked Measured Point	V-TOPO-MISC
	SPOT-ELV	SE PSE	Spot Elevation	V-SURV-SPOT C-TOPO-SPOT
	ALM-POST	AP	Aluminum Post	V-PROP-PINS
	ANGL-IRN	AI	Angle Iron Post	V-PROP-PINS
	BRAS-CAP	BCM	Standard Brass Cap Monument	V-PROP-PINS
	CON-POST	MN	Concrete Post Monument <i>brass cap on 75 cm tall concrete cylinder</i>	V-PROP-PINS
	DOMIN-IP	DIP	Dominion Iron Post	V-PROP-PINS
	IRON-PIN	IP	Standard Iron Pin	V-PROP-PINS
	LED-PLUG	LP	Lead Plug	V-PROP-PINS
	ROK-POST	RPM	Rock Post Monument	V-PROP-PINS
	ROUND-IP	RIP	Non-Standard Round Iron Post	V-PROP-PINS
	SQUAR-IP	SIP	Non-Standard Square Iron Post	V-PROP-PINS
	WIT-POST	WP	Witness Post	V-PROP-PINS
	WOODPOST	WN	Wooden Post	V-PROP-PINS

MoT Section	1250	TAC Section	Not Applicable
-------------	------	-------------	----------------

Symbol	Name	Feature	Description	Layer
	REFPOINT	RP	Reference Point	V-CTRL-REFP
	DETALHUB	DH	Detail / Traverse Hub	V-CTRL-MINR
	BENCHMRK	BM	Benchmark	V-CTRL-MAJR
	MONUMENT	LM	Control Monument <i>geodetic benchmark</i> <i>integrated survey monument</i>	V-CTRL-GEOD
	TESTPIT	TT	Geotechnical Test Pit	B-BORE-SYMB-TPIT
	TESTHOLE	AH BRH TH	Geotechnical Auger Hole Geotechnical Borehole Geotechnical Test Hole	B-BORE-SYMB-HOLE B-BORE-SYMB-HOLE B-BORE-SYMB-THOL













MoT Section	1250	TAC Section	Not Applicable
-------------	------	-------------	----------------

1250.03 AERIAL UTILITIES

Symbol	Name	Feature	Description	Layer
	T-BOOTH	PB	Telephone Booth	V-COMM-SYMB C-COMM-SYMB
	TEL-GUY	GT	Phone Guy Pole	V-COMM-SYMB C-COMM-SYMB
	TEL-PEDL	PD	Telephone Pedestal	V-COMM-SYMB C-COMM-SYMB
	TEL-POLE	TP	Telephone Pole	V-COMM-SYMB C-COMM-SYMB
	POWR-GUY	GE	Power Guy Pole	V-POWR-SYMB
	HT-POLE	HV	High Tension Pole	V-POWR-SYMB C-POWR-SYMB
	HT-TOWER	HT	High Tension Tower	V-POWR-SYMB C-POWR-SYMB
	PT-GUY	GY	Power / Phone Guy Pole	V-POWR-SYMB C-POWR-SYMB
	PT-POLE	PT	Power / Telephone Pole	V-POWR-SYMB C-POWR-SYMB
	PWR-POLE	PP	Power Pole	V-POWR-SYMB C-POWR-SYMB
	TRNS-PT	PH	Power / Telephone Pole with Transformer	V-POWR-SYMB C-POWR-SYMB
	TRNS-PWR	PS	Power Pole with Transformer	V-POWR-SYMB C-POWR-SYMB
	DEADMAN	DM	Deadman	V-UTIL-SYMB C-UTIL-SYMB
	GUY-WIRE	AN or GW	Anchor or Guy Wire	V-UTIL-SYMB C-UTIL-SYMB













MoT Section	1250	TAC Section	Not Applicable
-------------	------	-------------	----------------

1250.04 DETAIL

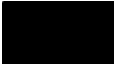

Symbol	Name	Feature	Description	Layer
	COM-SIGN	CSN PCSN	Commercial Sign	V-SIGN C-SIGN
	DELINPST	DO PDO	Delineator Post	V-SIGN C-SIGN
	CON-PILR	CN PCN	Concrete Pillar	V-SITE-MISC C-STRC-MISC
	FLAGPOLE	PF PPF	Flagpole	V-SITE-MISC C-STRC-MISC
	GARDPOST	PO PPO	Guard Post	V-SITE-MISC C-STRC-MISC
	GATEPOST	GA PGA	Gate Post	V-SITE-MISC C-STRC-MISC
	MAIL-BOX	MB PMB	Mailbox	V-SITE-MISC C-STRC-MISC
	DEC-TREE	DT	Decorative Tree	V-SITE-VEGE-TREE
	TREE	TE	Tree	V-SITE-VEGE-TREE
	PILING	PG PPG	Piling	V-STRC C-STRC-MISC
	SWAMP	MS	Swamp	V-TOPO-WETL
	WELL	W PW	Well	V-UTIL-SYMB C-UTIL-SYMB

MoT Section	1250	TAC Section	Not Applicable
-------------	------	-------------	----------------

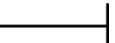
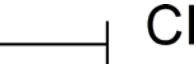
1250.05 DRAINAGE



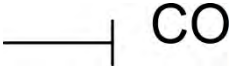







Symbol	Name	Feature	Description	Layer
	MANHOLE	MH	Existing Manhole	V-UTIL-SYMB
 MH Power	MH-POWER	MHP	Existing Manhole - Power	V-POWR-SYMB
 MH San	MH-SAN	MHS	Existing Manhole - Sanitary Sewer	V-SSWR-SYMB
 MH Storm	MH-STORM	MHM	Existing Manhole - Storm Sewer	V-STRM-SYMB
 MH Tel	MH-TEL	MHT	Existing Manhole - Telephone	V-COMM-SYMB
 MH Unk	MH-UNK	MHU	Existing Manhole - Unknown	V-UTIL-SYMB
 MH Vault	MH-VAULT	MHV	Existing Manhole - Vault	V-UTIL-SYMB
 MH Water	MH-WATER	MHW	Existing Manhole - Vault	V-WATR-SYMB
 MH/CB Drywell	DRYWELL	DRY	Existing Manhole/Catch Basin - Drywell	V-UTIL-SYMB
	CB	CB	Existing Catch Basin	V-STRM-SYMB
	CB-MH	CM	Catch Basin Manhole	V-STRM-SYMB
	ASP-SPLW	AS PAS	Asphalt Spillway	V-DRAN-SWAY C-DRAN-SWAY
	DRNGRATE	DG	Drainage Grate	V-STRM-SYMB
	CULVT	CUL	Culvert	V-DRAN-PIPE-SYMB
	CULVTIN	CI	Culvert Inlet	V-DRAN-PIPE-SYMB

MoT Section	1250	TAC Section	Not Applicable
-------------	------	-------------	----------------

Symbol	Name	Feature	Description	Layer
	CULVTOUT	CO	Culvert Outlet	V-DRAN-PIPE-SYMB
	CUL-KINK	KK	Culvert Kink	V-DRAN-PIPE-SYMB









MoT Section	1250	TAC Section	Not Applicable
-------------	------	-------------	----------------

1250.06 PROPOSED DRAINAGE

Symbol	Name	Feature	Description	Layer
	PMANHOLE	MD	Proposed Manhole	C-UTIL-SYMB
	PM-POWER	MDP	Proposed Manhole - Power	C-POWR-SYMB
	PM-SAN	MDS	Proposed Manhole - Sanitary Sewer	C-SSWR-SYMB
	PM-STORM	MDM	Proposed Manhole - Storm Sewer	C-STRM-SYMB
	PM-TEL	MDT	Proposed Manhole - Telephone	C-COMM-SYMB
	PM-UNK	MDU	Proposed Manhole - Unknown	C-UTIL-SYMB
	PM-VAULT	MDV	Proposed Manhole - Vault	C-UTIL-SYMB
	PM-WATER	MDW	Proposed Manhole - Water	C-WATR-SYMB
	PDRYWELL	PDRY	Proposed Manhole/Catch Basin - Drywell	C-UTIL-SYMB
	PCB	PCB	Proposed Catch Basin	C-STRM-SYMB









MoT Section	1250	TAC Section	Not Applicable
-------------	------	-------------	----------------

1250.07 UNDERGROUND

Symbol	Name	Feature	Description	Layer
 BP	VENT	VP	Vent Pipe - Breather / Vent Pipe	V-OIL~-SYMB
 FC	FILL-CAP	FC	Filler Cap	V-OIL~-SYMB
 FP	GAS-PUMP	FU PFU	Fuel / Gas Pump Proposed Fuel / Gas Pump	V-OIL~-SYMB C-OIL~-SYMB
 FT	FUEL-TNK	FT PFT	Fuel Tank Proposed Fuel Tank	V-OIL~-SYMB C-OIL~-SYMB
 ST	SEPT-TNK	ST PST	Septic Tank Proposed Septic Tank	V-SSWR-SYMB C-SSWR-SYMB
 UM	UG-MRKER	UM	Underground Marker	V-UTIL-SYMB
 IJ	IRRGJBOX	IRJ	Irrigation - Junction Box	V-IRRG-SYMB
 IS	IRRGSPHD	IRS	Irrigation - Sprinkler Head	V-IRRG-SYMB
 XF	TRNS-FMR	UXF	Underground Electrical Transformer	V-POWR-SYMB C-POWR-SYMB









MoT Section	1250	TAC Section	Not Applicable
-------------	------	-------------	----------------

1250.08 ELECTRICAL

Symbol	Name	Feature	Description	Layer
 JB	JUNC-BOX	JB	Junction Box	V-UTIL-SYMB
 UP	UTIL-POL	UP	Utility Pole	V-UTIL-SYMB
 EO	ELE-OUTL	EO	Electrical Outlet	V-POWR-SYMB
 LS	LAMPSTND	LA	Lamp Standard	V-POWR-SYMB
 K	KIOSK	K	Utility Kiosk	V-UTIL-SYMB
 TRAF-SIG	TRAF-SIG	SN PSN	Signal - Traffic Signal Proposed Signal - Traffic Signal	V-UTIL-SYMB C-UTIL-SGNL
 TRAF-CNTR	TRAF-CNTR	TA PTA	Traffic Counter Proposed Traffic Counter	V-UTIL-SYMB C-UTIL-SGNL
 CONT-BOX	CONT-BOX	TX PTX	Traffic Signal Control Box Proposed Traffic Signal Control Box	V-UTIL-SYMB C-UTIL-SGNL









MoT Section	1250	TAC Section	Not Applicable
-------------	------	-------------	----------------

1250.09 METERS

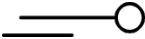
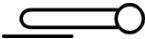
Symbol	Name	Feature	Description	Layer
 V	VALVE	V	Valve	V-UTIL-SYMB
 SV	SERV-MTR	SV	Meter - Service Meter	V-UTIL-SYMB
 GV	GAS-VALV	GV	Gas Valve	V-NGAS-SYMB
 WV	WATRVALV	WV	Valve - Water Valve	V-WATR-SYMB
 WM	WATR-MTR	WM	Meter - Water Meter	V-WATR-SYMB
 FH	FIRE-HYD	FH	Fire Hydrant	V-WATR-SYMB
 SD	STANPIPE	SDP	Standpipe - Water Blowoff	V-WATR-SYMB C-WATR-SYMB
 AIR	AIR-VALV	AR	Valve - Air Release Valve	V-UTIL-SYMB

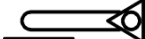

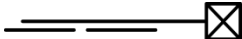







MoT Section	1250	TAC Section	Not Applicable
-------------	------	-------------	----------------

1250.10 ROAD SIGNS

Symbol	Name	Description	Layer
	ONE-POST	One Post (wood / perforated square steel / round steel)	V-SIGN
	TWO-POST	Two Post (wood / perforated square steel)	V-SIGN
	BRKAWAY	Breakaway (steel)	V-SIGN
	TYPE-3	Standard Davit Pole - Type 3	V-SIGN
	TYPE-1	Standard Combination Pole - Type 1	V-SIGN
	TYPE-6	Heavy Duty Davit Pole - Type 6	V-SIGN
	TYPE-7	Heavy Duty Combination Pole - Type 7	V-SIGN
	TYPE-H	Heavy Pole - Type H	V-SIGN
	COMB-H	Heavy Combination Pole - Type H	V-SIGN
	CANTILVR	Cantilever Structure	V-SIGN
	BRIDGE	Sign Bridge Structure	V-SIGN

MoT Section	1250	TAC Section	Not Applicable
-------------	------	-------------	----------------

1250.11 LANE ARROWS















Symbol	Name	Feature	Description	Layer
	HARO	(none)	Straight Through Lane <i>indicates direction of travel</i>	V-ROAD-ARRW C-ROAD-ARRW
	HAROLT	(none)	Left Turn Lane <i>indicates direction of travel</i>	V-ROAD-ARRW C-ROAD-ARRW
	HARORT	(none)	Right Turn Lane <i>indicates direction of travel</i>	V-ROAD-ARRW C-ROAD-ARRW
	HAROSTLT	(none)	Straight Through, Left Turn Lane <i>indicates direction of travel</i>	V-ROAD-ARRW C-ROAD-ARRW
	HAROSTRT	(none)	Straight Through, Right Turn Lane <i>indicates direction of travel</i>	V-ROAD-ARRW C-ROAD-ARRW
	ARO	(none)	Straight Through Lane <i>shows pavement marking location and size</i>	V-ROAD-MRKG-ARRW C-ROAD-MRKG-ARRW
	AROLT	(none)	Left Turn Lane <i>shows pavement marking location and size</i>	V-ROAD-MRKG-ARRW C-ROAD-MRKG-ARRW
	ARORT	(none)	Right Turn Lane <i>shows pavement marking location and size</i>	V-ROAD-MRKG-ARRW C-ROAD-MRKG-ARRW
	AROSTLT	(none)	Straight Through, Left Turn Lane <i>shows pavement marking location and size</i>	V-ROAD-MRKG-ARRW C-ROAD-MRKG-ARRW
	AROSTRT	(none)	Straight Through, Right Turn Lane <i>shows pavement marking location and size</i>	V-ROAD-MRKG-ARRW C-ROAD-MRKG-ARRW

1250.12 MISCELLANEOUS ARROWS











Symbol	Name	Feature	Description	Layer
	DR-ARROW	(none)	Water Flow Direction Arrow	V-DRAN C-DRAN
See 1250.19	NORTH	(none)	North Arrow	G-ANNO-NRTH

MoT Section	1250	TAC Section	Not Applicable
-------------	------	-------------	----------------

1250.13 ROUNDABOUT LANE ARROWS

Symbol	Name	Feature	Description	Layer
	HRA-TI	(none)	Straight Through, Inside Lane <i>indicates direction of travel</i>	V-ROAD-ARRW C-ROAD-ARRW
	HRA-TRI	(none)	Straight Through and Right Turn, Inside Lane <i>indicates direction of travel</i>	V-ROAD-ARRW C-ROAD-ARRW
	HRA-TLI	(none)	Straight Through and Left Turn, Inside Lane <i>indicates direction of travel</i>	V-ROAD-ARRW C-ROAD-ARRW
	HRA-TRLI	(none)	Straight Through, Right and Left Turn, Inside Lane <i>indicates direction of travel</i>	V-ROAD-ARRW C-ROAD-ARRW
	HRA-LI	(none)	Left Turn, Inside Lane <i>indicates direction of travel</i>	V-ROAD-ARRW C-ROAD-ARRW
	HRA-RLI	(none)	Right and Left Turn, Inside Lane <i>indicates direction of travel</i>	V-ROAD-ARRW C-ROAD-ARRW
	HRA-T	(none)	Straight Through Lane <i>indicates direction of travel</i>	V-ROAD-ARRW C-ROAD-ARRW
	HRA-TR	(none)	Straight Through and Right Turn Lane <i>indicates direction of travel</i>	V-ROAD-ARRW C-ROAD-ARRW
	HRA-TL	(none)	Straight Through and Left Turn Lane <i>indicates direction of travel</i>	V-ROAD-ARRW C-ROAD-ARRW
	HRA-TRL	(none)	Straight Through, Right and Left Turn Lane <i>indicates direction of travel</i>	V-ROAD-ARRW C-ROAD-ARRW
	HRA-RL	(none)	Right and Left Turn Lane <i>indicates direction of travel</i>	V-ROAD-ARRW C-ROAD-ARRW
	HRA-R	(none)	Right Turn Lane <i>indicates direction of travel</i>	V-ROAD-ARRW C-ROAD-ARRW
	HRA-ONLY	(none)	Lane "ONLY" Marking <i>indicates direction of travel</i>	V-ROAD-ARRW C-ROAD-ARRW
	RA-TI	(none)	Straight Through, Inside Lane <i>shows pavement marking location and size</i>	V-ROAD-MRKG-ARRW C-ROAD-MRKG-ARRW
	RA-TRI	(none)	Straight Through and Right Turn, Inside Lane <i>shows pavement marking location and size</i>	V-ROAD-MRKG-ARRW C-ROAD-MRKG-ARRW

MoT Section	1250	TAC Section	Not Applicable
-------------	------	-------------	----------------

Symbol	Name	Feature	Description	Layer
	RA-TLI	(none)	Straight Through and Left Turn, Inside Lane <i>shows pavement marking location and size</i>	V-ROAD-MRKG-ARRW C-ROAD-MRKG-ARRW
	RA-TRLI	(none)	Straight Through, Right/Left Turn, Inside Lane <i>shows marking location and size</i>	V-ROAD-MRKG-ARRW C-ROAD-MRKG-ARRW
	RA-LI	(none)	Left Turn, Inside Lane <i>shows pavement marking location and size</i>	V-ROAD-MRKG-ARRW C-ROAD-MRKG-ARRW
	RA-RLI	(none)	Right and Left Turn, Inside Lane <i>shows pavement marking location and size</i>	V-ROAD-MRKG-ARRW C-ROAD-MRKG-ARRW
	RA-T	(none)	Straight Through Lane <i>shows pavement marking location and size</i>	V-ROAD-MRKG-ARRW C-ROAD-MRKG-ARRW
	RA-TR	(none)	Straight Through and Right Turn Lane <i>shows pavement marking location and size</i>	V-ROAD-MRKG-ARRW C-ROAD-MRKG-ARRW
	RA-TL	(none)	Straight Through and Left Turn Lane <i>shows pavement marking location and size</i>	V-ROAD-MRKG-ARRW C-ROAD-MRKG-ARRW
	RA-TRL	(none)	Straight Through, Right and Left Turn Lane <i>shows pavement marking location and size</i>	V-ROAD-MRKG-ARRW C-ROAD-MRKG-ARRW
	RA-RL	(none)	Right and Left Turn Lane <i>shows pavement marking location and size</i>	V-ROAD-MRKG-ARRW C-ROAD-MRKG-ARRW
	RA-R	(none)	Right Turn Lane <i>shows pavement marking location and size</i>	V-ROAD-MRKG-ARRW C-ROAD-MRKG-ARRW
	RA-ONLY	(none)	Lane "ONLY" Marking <i>shows pavement marking location and size</i>	V-ROAD-MRKG-ARRW C-ROAD-MRKG-ARRW

MoT Section	1250	TAC Section	Not Applicable
-------------	------	-------------	----------------

1250.14 CONSTRUCTION NOTES

Symbol	Name	Feature	Description	Layer
ABANDON	ABANDON	n/a	Abandon	G-ANNO-NOTE
ADJUST	ADJUST	n/a	Adjust	G-ANNO-NOTE
BREAK & ENTER EXISTING	BRK-ENTER	n/a	Break and Enter Existing	G-ANNO-NOTE
FENCE TYPE 'B'	FENC-TYP	n/a	Fence Type 'B'	G-ANNO-NOTE
BEGIN FENCE	BEG-FENC	n/a	Begin Fence	G-ANNO-NOTE
END FENCE	END-FENC	n/a	End Fence	G-ANNO-NOTE
SANDBAG INLET	SANDBAG	n/a	Sandbag Inlet	G-ANNO-NOTE
SWALE	SWALE	n/a	Swale	G-ANNO-NOTE
REMOVE	REMOVE	n/a	Remove	G-ANNO-NOTE

MoT Section	1250	TAC Section	Not Applicable
-------------	------	-------------	----------------

1250.15 MISCELLANEOUS NOTES

Block name	AREA
Description	Right Of Way Area Note
Layer	G-ANNO-NOTE

R/W AREA VALUES

These values denote the right-of-way area within the sheet join lines.

Areas from adjoining sheets are included if (TOTAL) is specified.

Block name	PROFNOTE
Description	Profile Note with Superelevation (attribute)
Layer	G-ANNO-NOTE

NOTE:

1. Elevations shown are Finished Grade
2. Embankment figures shown represent Compacted Quantities
3. Maximum project Superelevation is 6%

Block name	PROFNOT1
Description	Profile Note
Layer	G-ANNO-NOTE

NOTE:

1. Elevations shown are Finished Grade
2. Embankment figures shown represent Compacted Quantities

MoT Section	1250		TAC Section	Not Applicable
-------------	------	--	-------------	----------------

Block name	HAULNOTE
Description	Volume Overhaul Note
Layer	G-ANNO-NOTE

NOTE:

THIS VOLUME OVERHAUL DIAGRAM IS A PLOT ON WHICH SHRINKAGE AND SWELL ADJUSTMENT FACTORS HAVE BEEN APPLIED TO THE EXCAVATION QUANTITIES. THE VERTICAL SCALE SHOULD THEREFORE NOT BE USED TO SCALE IN SITU EXCAVATION QUANTITIES TO BE OVERHAULED. THE HAUL FIGURES SHOWN REPRESENT THE ACTUAL ESTIMATED UNADJUSTED EXCAVATION QUANTITIES.

Block name	DESSPEED
Description	Design Speed (with attributes)
Layer	G-ANNO-NOTE

DESIGN SPEED 50 km/h TO STA 100+00

Block name	DES-RW
Description	Right Of Way Acquisition - Senior Designer Signature
Layer	G-ANNO-NOTE

FOR R/W ACQUISITION ONLY

_____ SENIOR DESIGNER

DATE _____

MoT Section	1250	TAC Section	Not Applicable
-------------	------	-------------	----------------

1250.16 GEOTECH LEGENDS













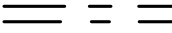

Block name	KEYMAP
Description	Key Map (with attributes)
Layer	B-ANNO-LEGN

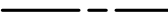
<h1>KEY MAP</h1>			
NTS Map Number :	Hwy 1JV	Scale :	1:2,000,000

MoT Section	1250	TAC Section	Not Applicable
-------------	------	-------------	----------------

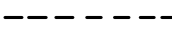
Block name	LEG-PIT
Description	Pit Development Legend
Layer	B-ANNO-LEGN

LEGEND

	NATURAL EMBANKMENT		MAINTAINED ROAD
	PIT FACE/STOCKPILE		ACCESS ROAD
	TEST HOLE		TREE LINE
	TEST PIT		SWAMP
	DISTRICT LOT LINE		FENCE
	MONUMENT		CREEK
	IRON PIN		TRAIL
	20M CONTOUR		BUILDING LOCATION
	100M CONTOUR		

MoT Section	1250	TAC Section	Not Applicable
-------------	------	-------------	----------------

Block name	LEG-SOIL
Description	Soil Classification Legend
Layer	B-ANNO-LEGN

MATERIALS CLASSIFICATION LEGEND

MAJOR DIVISIONS		SYMBOL	SOIL TYPE
COARSE GRAINED SOILS	GRAVEL AND GRAVELLY SOILS	GW	WELL GRADED GRAVELS OR GRAVEL-SAND MIXTURES, < 5% FINES
		GP	POORLY-GRADED GRAVELS OR GRAVEL-SAND MIXTURES, < 5% FINES
		GM*	SILTY GRAVELS GRAVEL-SAND-SILT MIXTURES
		GC*	CLAYEY GRAVELS GRAVEL-SAND-CLAY MIXTURES
	SAND AND SANDY SOILS	SW	WELL-GRADED SANDS OR GRAVELLY SANDS, < 5% FINES
		SP	POORLY-GRADED SANDS OR GRAVELLY SANDS, < 5% FINES
		SM*	SILTY SANDS SAND-SILT MIXTURES
		SC*	CLAYEY SANDS SAND-CLAY MIXTURES
FINE GRAINED SOILS	SILTS AND CLAYS w _L <50	ML	INORGANIC SILTS AND VERY FINE SANDS, ROCK FLOUR, SILTY OR CLAYEY FINE SANDS OR CLAYEY SILTS WITH SLIGHT PLASTICITY
		CL	INORGANIC CLAYS OF LOW TO MEDIUM PLASTICITY, GRAVELLY CLAYS, SANDY CLAYS, SILTY CLAYS, LEAN CLAYS
		OL	ORGANIC SILTS AND ORGANIC SILT-CLAYS OF LOW PLASTICITY
	SILTS AND CLAYS w _L >50	MH	INORGANIC SILTS, MICACEOUS OR DIATOM-ACEOUS FINE SANDY OR SILTY SOILS, PLASTIC SILTS
		CH	INORGANIC CLAYS OF HIGH PLASTICITY, FAT CLAYS
		OH	ORGANIC CLAYS OF MEDIUM TO HIGH PLASTICITY, ORGANIC SILTS
ORGANIC	Pt	PEAT AND OTHER HIGHLY ORGANIC SOILS	
TOPSOIL	TS	TOPSOIL WITH ROOTS, ETC.	
COBBLES	SB	ROCK FRAGMENTS AND COBBLES, PARTICLE SIZE 75mm TO 300mm	
BOULDERS	LB	LARGE BOULDERS, PARTICLE SIZE OVER 300mm	
BEDROCK	BR	BEDROCK	
USE DUAL SYMBOL FOR SOILS HAVING 5 - 12% PASSING .075 SIEVE *GM1; GC1; SM1; SC1; 12 - 20% GM2; GC2; SM2; SC2; 20 - 30% GM3; GC3; SM3; SC3; 30 - 40% GM4; GC4; SM4; SC4; 40 - 50%			
} PASSING .075mm SIEVE			

REV. 90-04-26

MoT Section	1250	TAC Section	Not Applicable
-------------	------	-------------	----------------

Block name	LEG-TH
Description	Testhole Legend
Layer	B-ANNO-LEGN

LEGEND

TH94-00 TESTHOLE
 Number and Location

Block name	MAGNORTH
Description	Magnetic North (with declination attribute)
Layer	B-ANNO-LEGN

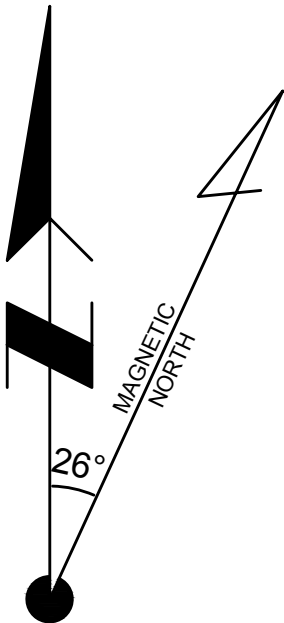











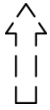
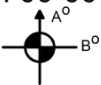

1250.17 GEOTECH GENERAL





Symbol	Name	Feature	Description	Layer
FC X	FEATURE	n/a	Feature Code (attribute)	B-BORE-SYMB-FEAT
HUB △	HUB	n/a	Hub (attribute)	B-BORE-SYMB-HUBA

MoT Section	1250	TAC Section	Not Applicable
-------------	------	-------------	----------------

1250.18 GEOTECH PIT DEVELOPMENT

Symbol	Name	Feature	Description	Layer
	CRUSHER	n/a	Crusher Setup	B-BORE-SYMB
	EXCAVATE	n/a	Excavation	B-BORE-SYMB
	PROCESS	n/a	Process	B-BORE-SYMB
	DEVDIR	n/a	Development Direction	B-BORE-SYMB
	DEVEXT	n/a	Future Development Direction	B-BORE-SYMB
SI 00-00 	SLOPE	GSI	Geotechnical Slope Indicator	B-BORE-SYMB-TEST
	ST	n/a	Stockpile	B-BORE-SYMB
	STCRUSH	n/a	Stockpile Crush	B-BORE-SYMB
	STOVERBU	n/a	Stockpile Overburden	B-BORE-SYMB
	STOVSIZ	n/a	Stockpile Oversize	B-BORE-SYMB
	STTOPSO	n/a	Stockpile Topsoil	B-BORE-SYMB
	STWASTE	n/a	Stockpile Waste	B-BORE-SYMB
	STREJECT	n/a	Stockpile Reject	B-BORE-SYMB
	STUNACEP	n/a	Stockpile Unacceptable	B-BORE-SYMB

MoT Section	1250	TAC Section	Not Applicable
-------------	------	-------------	----------------

Symbol	Name	Feature	Description	Layer
THyy-nn 	TESTHOLA	n/a	Testhole with # (attribute)	B-BORE-SYMB-HOLE
TPyy-nn 	TESTPITA	n/a	Testpit with # (attribute)	B-BORE-SYMB-TPIT
PZ 00-00 	PIEZMTR	PZ	Piezometer (attribute)	B-BORE-SYMB-TEST
SP 00-00 	SPLATE	SP	Settlement Plate (Pipe) (attribute)	B-BORE-SYMB-TEST
 OW	OWELL	OW	Well - Observation Well	B-BORE-SYMB-TEST

MoT Section	1250	TAC Section	Not Applicable
-------------	------	-------------	----------------

1250.19 TITLEBLOCKS AND FRAMES

Use all of these blocks at ½ scale for 11x17 plots.

Block name	FRAME
Description	POLYLINE border with two POINTs defining the lower-left and upper-right extents of a standard D-size sheet. The blank area on the left is for binding.
Layer	G-ANNO-TTLB

Block name	FOLDMKS and FOLDMKS1
Description	Adds tick marks to the FRAME block to show fold locations when folding 11x17 plots to fit in a standard letter size document/binder. Use the same insertion point as the FRAME block. FOLDMKS places the ticks on the outside of the frame, FOLDMKS1 places the ticks on the inside of the frame.
Layer	G-ANNO-TTLB

Block name	TITLEBLOCKS
Description	Adds standard titleblocks (dynamic block with attributes) to FRAME (use the same insertion point as the FRAME block)
Dynamic Properties	Select from seven titleblock configurations <ol style="list-style-type: none"> 1. Standard 2. Standard Stacked 3. Standard Stacked (Consultant Logo Box) 4. Low Profile (Horizontal) 5. Low Profile (Vertical) 6. Small Key Plan 7. Large Key Plan
Layer	G-ANNO-TTLB



Block name	SCALES
Description	Adds drawing scales to TITLEBLOCKS (dynamic block) (insert to a polyline vertex, to left of SCALE label in TITLEBLOCKS)
Dynamic Properties	Select from sixteen different scales <ul style="list-style-type: none"> • 1:50 • ... • 1:50,000 • 1:100 Horizontal 1:50 Vertical • ... • 1:2000 Horizontal 1:200 Vertical Select horizontal or vertical orientation. Vertical is used for the Low Profile (Vertical) titleblock configuration.
Layer	G-ANNO-TTLB

MoT Section	1250	TAC Section	Not Applicable
-------------	------	-------------	----------------

Block name	BCLOGO
Description	Adds small BC Logo (dynamic block) to TITLEBLOCKS (insert to the top left corner of the title area of TITLEBLOCKS)
Dynamic Properties	Select from four configurations 1. Horizontal – B/W 2. Horizontal – Colour 3. Vertical – B/W 4. Vertical – Colour Vertical is used for the Low Profile (Vertical) titleblock configuration
Layer	G-ANNO-TTLB

Block name	BCMAPS
Description	Adds regional/district map logos (dynamic block) to TITLEBLOCKS (insert to the top right corner of the title area of TITLEBLOCKS)
Dynamic Properties	Select from sixteen different regional or district maps 1. Northern Region Map 2. South Coast Region Map 3. Southern Interior Region Map 4. Bulkley District Map ... 16. West Kootenay District Map Select horizontal or vertical orientation. Vertical is used for the Low Profile (Vertical) titleblock configuration.
Layer	G-ANNO-TTLB

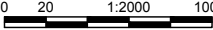

Standard Titleblock (blocks shown are: TITLEBLOCKS, SCALES, BCLOGO and BCMAPS)

			 BRITISH COLUMBIA		MINISTRY OF TRANSPORTATION AND INFRASTRUCTURE REGION_NAME BRANCH				
SCALE 0 20 1:2000 100m 			CAD FILENAME _____ CAD FILENAME DATE _____ YYYY-MM-DD						
REV	DATE	REVISIONS	SIGNATURE						
			SENIOR DESIGNER _____ DATE YYYY-MM-DD		DESIGNED _____ DESIGNED BY _____ DATE YYYY-MM-DD QUALITY CONTROL _____ QC BY _____ DATE YYYY-MM-DD QUALITY ASSURANCE _____ QA BY _____ DATE YYYY-MM-DD DRAWN _____ DRAWN BY _____ DATE YYYY-MM-DD		FILE NUMBER PROJECT NUMBER REG DRAWING NUMBER REV FILE NUMBER PROJECT NUMBER R DWG NUMBER A		



See [Figure 1220.C](#) showing a typical drawing (FRAME plus TITLEBLOCKS).

MoT Section	1250	TAC Section	Not Applicable
-------------	------	-------------	----------------

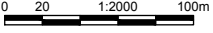

Standard Stacked Titleblock (with Consultant Logo box)

		MINISTRY OF TRANSPORTATION AND INFRASTRUCTURE REGION_NAME BRANCH			
SCALE  CAD FILENAME _____ CAD FILENAME _____ DATE _____ YYYY-MM-DD					
REV	DATE	REVISIONS	SIGNATURE		
SENIOR DESIGNER _____ DATE _____ YYYY-MM-DD			DESIGNED _____ DESIGNED BY _____ DATE _____ YYYY-MM-DD QUALITY CONTROL _____ QC BY _____ DATE _____ YYYY-MM-DD QUALITY ASSURANCE _____ QA BY _____ DATE _____ YYYY-MM-DD DRAWN _____ DRAWN BY _____ DATE _____ YYYY-MM-DD		
FILE NUMBER	PROJECT NUMBER	REG	DRAWING NUMBER	REV	
FILE NUMBER	PROJECT NUMBER	R	DWG NUMBER	A	

Low Profile Titleblock (Horizontal Version)

SCALE  CAD FILENAME _____ CAD FILENAME _____ DATE _____ YYYY-MM-DD				MINISTRY OF TRANSPORTATION AND INFRASTRUCTURE REGION_NAME BRANCH			
REV	DATE	REVISIONS	SIGNATURE				
SENIOR DESIGNER _____ DATE _____ YYYY-MM-DD			DESIGNED _____ DESIGNED BY _____ DATE _____ YYYY-MM-DD QUALITY CONTROL _____ QC BY _____ DATE _____ YYYY-MM-DD QUALITY ASSURANCE _____ QA BY _____ DATE _____ YYYY-MM-DD DRAWN _____ DRAWN BY _____ DATE _____ YYYY-MM-DD			FILE NUMBER PROJECT NUMBER REG DRAWING NUMBER REV FILE NUMBER PROJECT NUMBER R DWG NUMBER A	

Large Key Plan

		MINISTRY OF TRANSPORTATION AND INFRASTRUCTURE REGION_NAME BRANCH			
REGIONAL MANAGER, ENGINEERING _____ DATE _____ YYYY-MM-DD					
REGIONAL DIRECTOR _____ DATE _____ YYYY-MM-DD					
FILE NUMBER	PROJECT NUMBER	REG	DRAWING NUMBER	REV	
FILE NUMBER	PROJECT NUMBER	R	DWG NUMBER	A	

Small Key Plan

The signature area from the large key plan is moved to the lower center of the drawing frame and the drawing number and revision box remain at the lower right.

REGIONAL MANAGER, ENGINEERING _____ DATE _____ YYYY-MM-DD		REGIONAL DIRECTOR _____ DATE _____ YYYY-MM-DD		DRAWING NUMBER REV DWG NUMBER A	
--	--	--	--	------------------------------------	--

MoT Section	1250		TAC Section	Not Applicable
-------------	------	--	-------------	----------------

Block name	FRONTPG and FRONTPG_COLOR
Description	Includes the large MOTLOGO or MOTLOGO_COLOR blocks plus title page titles. Requires FRAME block.
Layer	G-ANNO-TTLB

Block name	MOTLOGO and MOTLOGO_COLOR
Description	Large BC logo in black/grey or colour. Ministry title included.
Layer	G-ANNO-TTLB

See [Figure 1220.A](#) for an example title page.

Block name	NORTH
Description	North Arrow
Layer	G-ANNO-NRTH

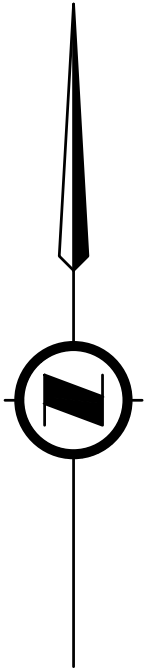

MoT Section	1260	TAC Section	Not Applicable
-------------	------	-------------	----------------

1260 AUTOCAD LINETYPES

1260.01 LINETYPE STANDARDS

The BC MoT Engineering Branch has developed standards for representing existing features and proposed design features that are to be shown on contract drawings.

The linetypes are defined in a standard AutoCAD LIN file (**BC MoT.lin**) and supported by a shape file (**BC MoT.shx**). These and other supplied files are available for consultant download as described in [Section 1240](#).

Shapes and Text in Linetypes

Many of the linetypes include custom shapes or text labels. All shapes are provided by the **BC MoT.shx** compiled shape file which must be present in the AutoCAD search path. All text labels use the **Standard** text style which should exist and be assigned the **RomanS.shx** font in all drawings.

A number of linetypes which use text labels were previously also the longest patterns. Most required polylines to be over 70m in length before the pattern would appear. All of these linetype patterns have been reduced by half so that the text label appears more frequently and so that the pattern will display for shorter polylines.

Linetype Names

Linetype names have changed a number of times since the original CLINE linetypes were created in the 1980's. For example, the linetype for rural white paint line (broken white line) has been BL, BC_EAD_RP and EAD_BWL and is now ALGN-BWL (Alignment – Broken White Line).

As the linetypes are pre-loaded into the standard drawing template and assigned to the default layers, the change in names should not be an issue.

Obsolete Linetypes

Previous standards included a large number of “continuous” linetypes with unique names. These names were used to identify non-patterned polylines within a more limited layer system.

Most “proposed” linetypes have also been eliminated. These patterns were very similar to

their “existing” counterparts with the primary difference being the colour. For example, UG-TEL (underground telephone) is now used for both the C-COMM-UGND and V-COMM-UGND layers.

Layer Linetype Assignment

All linetypes are pre-loaded into the latest BC MoT drawing template and assigned to various layers.

All entities are to be assigned a ByLayer linetype as per [Section 1240](#). One exception is the BAR-MB-L, BAR-MB-R, BAR-RB-L and BAR-RB-R alternate barrier linetypes. These may be assigned individually when the polyline represents the inner or outer edge of the barrier as opposed to the centre of the barrier.

Linetype Samples

Samples have been grouped into categories in the following subsections. These images have been taken from the **linetypes and hatch patterns** sample drawing file provided by the ministry.

Alignment and Barrier	1260.02
Construction and Existing Features	1260.03
Underground and Geotech	1260.04
Hydrology, Lot Boundary and Toe	1260.05
Topography And Wall	1260.06

Each linetype in the following sections includes a description, linetype name, a list of CAICE feature codes which use the linetype and a list of layers which are assigned the linetype.

Contour Intervals

Contour standards are shown in [Section 1260.07](#). The diagram describes the normal line weight for minor and major contours and the normal text height for contour information. Also shown are the contour intervals for various scales. Refer to [Section 1240.04](#) for contour label text style information.

Linetype Dimensions

[Section 1260.08](#) contains a table which describes the dimensions of each linetype in detail.

MoT Section	1260	TAC Section	Not Applicable
-------------	------	-------------	----------------

1260.02 ALIGNMENT AND BARRIER LINETYPES

Linetype Labels	Description, Name, CAiCE Feature Codes, AutoCAD Layers
-----------------	--

ALIGNMENT

Broken White Line	ALGN-BWL	BL	C-ROAD-MRKG-BRKN,V-ROAD-MRKG-BRKN
Broken White Line - Bus Bay/Pullout	ALGN-BWL-PUL		C-ROAD-MRKG-BUSB
Broken White Line - Reserved Lane	ALGN-BWL-RES		C-ROAD-MRKG-RSLN
Broken White Line - Roundabout Circulating Lane	ALGN-BWL-CIRC		C-ROAD-MRKG-RCLN
Broken White Line - Roundabout Yield Line	ALGN-BWL-YIELD		C-ROAD-MRKG-RYLN
Broken White Line - Urban	ALGN-BWL-URB	UPL	C-ROAD-MRKG-UPLN,V-ROAD-MRKG-URPL
Centreline	ALGN-CNTR	C,CL,PCL	C-ROAD-CNTR,V-ROAD-CNTR,V-ROAD-CNTR-LLIN
Deceleration or Acceleration Lane	ALGN-DECL	DECL	C-ROAD-MRKG-DECL,V-ROAD-MRKG-DECL
Double Yellow Line	ALGN-DYL	DL	V-ROAD-MRKG-YELD
Intersection Guiding Line	ALGN-IGL		C-ROAD-MRKG-IGLN
Path Tracker Linetype	ALGN-PATH		C-ROAD-TURN-FFEN
Shoulder	ALGN-SHLD	LS,RS,SH,SHLD	C-ROAD-SHLD,V-ROAD-GRVL-SHLD,V-ROAD-SHLD
Yellow Line	ALGN-YL	YL	V-ROAD-MRKG-YELO

BARRIERS

Cable Barrier with Posts	BAR-CABLE		C-ROAD-BARM-CABL,C-ROAD-BARR-CABL,V-ROAD-BARM-CABL
Guard Rail with Posts	BAR-GUARD	GS,PGS	C-ROAD-BARR-GRAL,V-ROAD-BARR-GRAL
Concrete Median Barrier - 2.5m	BAR-MB	MBR,PCMB	C-ROAD-BARM-CONC,V-ROAD-BARM-CONC
Concrete Median Barrier - 2.5m (inside left)	BAR-MB-L	MBR,PCMB	C-ROAD-BARM-CONC,V-ROAD-BARM-CONC
Concrete Median Barrier - 2.5m (inside right)	BAR-MB-R	MBR,PCMB	C-ROAD-BARM-CONC,V-ROAD-BARM-CONC
Concrete Roadside Barrier - 2.5m	BAR-RB	RB,PCRB	C-ROAD-BARR-CONC,V-ROAD-BARR-CONC
Concrete Roadside Barrier - 2.5m (inside left)	BAR-RB-L	RB,PCRB	C-ROAD-BARR-CONC,V-ROAD-BARR-CONC
Concrete Roadside Barrier - 2.5m (inside right)	BAR-RB-R	RB,PCRB	C-ROAD-BARR-CONC,V-ROAD-BARR-CONC

MoT Section	1260	TAC Section	Not Applicable
-------------	------	-------------	----------------

1260.03 CONSTRUCTION AND EXISTING FEATURES LINETYPES

Linetype Labels	Description, Name, CAiCE Feature Codes, AutoCAD Layers
-----------------	--

CONSTRUCTION

Berm in Cut or Fill	CONST-BERM	BE,PBE	C-ROAD-TOES-BERM,V-TOPO-BERM
Clearing and Grubbing	CONST-CLGR	GC,PGC	C-RWAY-CLGR-BNDY,V-SITE-VEGE-CLGR
Hog Fuel	CONST-HOGF	HF,PHF	C-SECT-TOPO-HOGF,C-TOPO-BNDY-HOGF,V-SITE-HOGF
Riprap	CONST-RRAP	RI,PRI	C-DRAN-RRAP,V-DRAN-RRAP
Stripping	CONST-STRIP	S,STRPLIM,STRIPNG	C-SECT-STRIP
Waste	CONST-WASTE	WE	V-TOPO-WAST

EXISTING FEATURES

Dirt Road	EXST-DIRTROAD	DR	V-ROAD-DIRT
Fence	EXST-FENCE	FE,PFE	C-SITE-FENC,V-SITE-FENC
Gravel - Gr. Driveway, Edge of Gr., Gr. Road	EXST-GRAVEL	GL,GD,EG,GR	V-ROAD-GRVL,V-SITE-GRVL
Railway	EXST-RAIL	RR	V-RAIL
Railway Ballast	EXST-RAILBALLAST	BA	V-RAIL-GRVL
Rest Area	EXST-RESTAREA	RA	V-ROAD-REST
Road	EXST-ROAD	RD	V-ROAD-ROAD
Toe (Existing)	EXST-TOE	LT,RT,TO	V-ROAD-TOES
Hedge Line, Bush Line, Tree Line	EXST-TREELINE	BH,HG,TL	V-SITE-VEGE-BUSH,V-SITE-VEGE-TROW
Garden, Lawn, Vegetation	EXST-VEG	GN,L,VN	V-SITE-VEGE,V-SITE-VEGE-TURF

MoT Section	1260	TAC Section	Not Applicable
-------------	------	-------------	----------------

1260.04 UNDERGROUND AND GEOTECH LINETYPES

Linetype Labels	Description, Name, CAiCE Feature Codes, AutoCAD Layers
-----------------	--

Linetype Label	Description, Name, CAiCE Feature Codes, AutoCAD Layers
UNDERGROUND	
Storm / Sewer Drain S	UG-DRAIN S DS,PDS S C-STRM-UGND,V-STRM-UGND
Underground Electrical Power UE	UG-ELEC UE UE,PUE UE C-POWR-UGND,V-POWR-UGND
Gas Main G	UG-GAS G GM,PGM G C-NGAS-UGND,V-NGAS-UGND
Underground Miscellaneous UG	UG-MISC UG UG,PUG UG C-UTIL-UGND,V-UTIL-UGND
Oil Line OIL	UG-OIL OIL POL OIL C-OIL~UGND,V-OIL~UGND
Pipeline (Not Plastic)	UG-PIPE CS,CT,PN,CUL V-DRAN-PIPE
Pipeline (Plastic)	UG-PLASTIC PC V-DRAN-PIPE-PLST
Sanitary Sewer Line SAN	UG-SAN SAN SU,PSU SAN C-SSWR-UGND,V-SSWR-UGND
Underground Telephone UT	UG-TEL UT UT,PUT UT C-COMM-UGND,V-COMM-UGND
Water Main W	UG-WATER W WR,PWR W C-WATR-UGND,V-WATR-UGND

Linetype Label	Description, Name, CAiCE Feature Codes, AutoCAD Layers
GEOTECH	
Type A - Solid Rock	GEO-TYPE-A TYPE-A,TYPE-A1,TYPE-A2,TYPE-A3 C-SECT-TYPA
Type B - Over 50% Broken Rock	GEO-TYPE-B TYPE-B,TYPE-B1,TYPE-B2,TYPE-B3 C-SECT-TYPB
Type C - Requires Rippling	GEO-TYPE-C TYPE-C,TYPE-C1,TYPE-C2,TYPE-C3 C-SECT-TYPC
Water Table Elevation (Estimated)	GEO-WTE EWT WTE B-BORE-ESWT
Water Table Elevation (Measured)	GEO-WTM MWT WTM B-BORE-MSWT

MoT Section	1260	TAC Section	Not Applicable
-------------	------	-------------	----------------

1260.05 HYDROLOGY, LOT BOUNDARY AND TOE LINETYPES

Linetype Labels	Description, Name, CAiCE Feature Codes, AutoCAD Layers
-----------------	--

HYDROLOGY

Ditch, Creek or Stream Center	HYD-CNTR	CK,DC,SM,PDC	C/V-DRAN-DTCH-CNTR,V-TOPO-WATR-CNTR,V-TOPO-WATR-STRE
Ditch, Creek or Stream Center (Reverse)	HYD-CNTR-R	PDC	C/V-DRAN-DTCH-CNTR,V-TOPO-WATR-CNTR,V-TOPO-WATR-STRE
Ditch Edge	HYD-DITCH	DE	V-DRAN-DTCH-EDGE
Edge of Water	HYD-EW EW	EW	V-TOPO-WATR-EDGE
High Water Mark	HYD-HW HWM	HW	V-TOPO-WATR-HIGH
High Water Mark (Extreme)	HYD-HWE	EH	V-TOPO-WATR-EHWM
Seepage	HYD-SEEP	SG	V-TOPO-WATR-SEEP

LOT BOUNDARIES

Easement	LOT-EA	EA,PTLCA	C-RWAY-TLCA,V-PROP-ESMT
Gazette Boundary	LOT-GB	GB	V-PROP-GAZT
International Boundary	LOT-IB	IB	V-PROP-BNDY-INTL
Quarter Section Line	LOT-QS	QS	V-PROP-QTRS
Right of Way	LOT-RW	PRW	C-RWAY-BNDY
Section Line / District Lot Boundary	LOT-SL	SL	V-PROP-SECT

TOES

Base of Bridge End Fill	TOES-BBEF	PBBEFILL	C-ROAD-TOES-BBEF
Shoulder Excavation Start	TOES-SHEX	PSHXL,PSHXR	C-ROAD-TOES-SHEX
Toe (Design)	TOES-TOE	PTO,PTC,PTF,SURFLIM,BNKS,CUT,STKCUT,FILL,STKFIL	C-ROAD-TOES,C-ROAD-TOES-SURF

MoT Section	1260	TAC Section	Not Applicable
-------------	------	-------------	----------------

1260.06 TOPOGRAPHY AND WALL LINETYPES

Linetype Labels	Description, Name, CAiCE Feature Codes, AutoCAD Layers
-----------------	--

TOPOGRAPHY

Base of Slope or Embankment	TOPO-BSLP	BS	V-TOPO-BOTB
Ground or Pavement Crack	TOPO-CRACK	GK,PK	V-ROAD-PVMT-CRCK,V-TOPO-CRCK
Type A Horizon	TOPO-HORIZON-A	A	V-TOPO-ROCK-HRZA
Marsh / Swamp	TOPO-MARSH	MS	V-TOPO-WETL
Solid Rock or Top of Rock	TOPO-ROCK	SR,TR	V-TOPO-ROCK-SOLD,V-TOPO-ROCK-TRCK
Sand	TOPO-SAND	SA	V-TOPO-SAND
Slide, Scarp, Sluff Line	TOPO-SLIDE	SF	V-TOPO-SLGH
Talus, Broken or Loose Rock or Base of Rock	TOPO-TALUS	BN,BR,LR,T	V-TOPO-ROCK-BRCK,V-TOPO-ROCK-BRKN,V-TOPO-ROCK-LOOS,V-TOPO-TALS
Trail - Mapping Requirement	TOPO-TRAIL	TI	V-TOPO-TRAL
Top of Slope or Embankment	TOPO-TSLP	TB	V-TOPO-TOPB

WALLS

Wall (Design)	WALL-DESIGN	PBI,PHD,PRE,PWW	C-STRC-WALL-BINW,...,WALL-HEAD,...,WALL-RETN,...,WALL-WING
Wall (Existing)	WALL-EXIST	BI,HD,RE,WW	V-STRC-WALL-BINW,...,WALL-HEAD,...,WALL-RETN,...,WALL-WING

1260.07 CONTOUR INTERVALS

SITE PLAN

1 : 250

Use 0.5 m contour intervals.

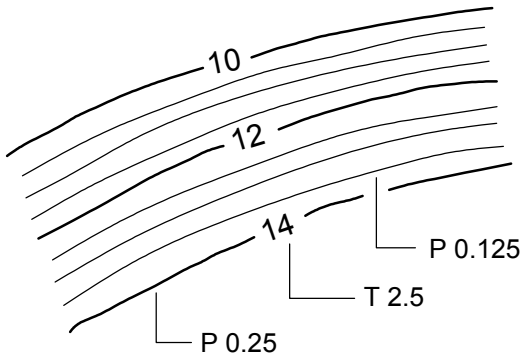

PLAN

1 : 500

Use 2 m contour intervals, accentuate 10 m contours.

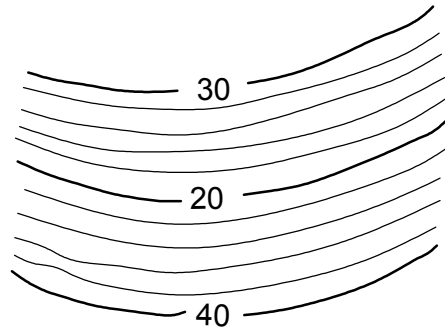

T = Text height in mm
P = Pen width in mm

Depending on the type of plotter, users may have to adjust pen colours to produce a legible screened contour plot that does not obscure the other drawing entities.

PLAN

1 : 1000

Use 2 m contour intervals, accentuate 10 m contours.

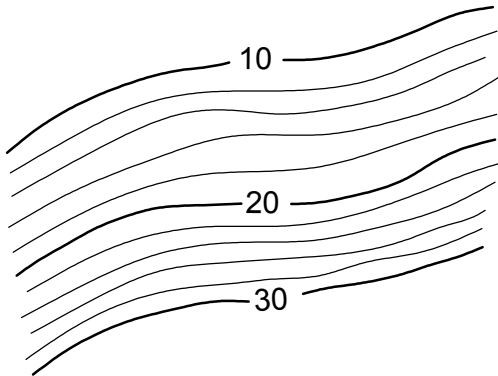

MAPPING RECCE TYPE

1 : 5000

For 5 m contour intervals, accentuate 25 m contours.

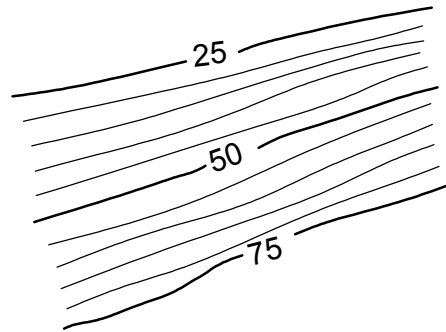

For 10 m contour intervals, accentuate 50 m contours.

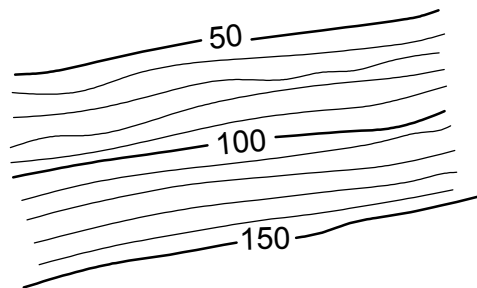

KEY PLANS: Variable Scales

Use 2 m, 5 m, or 10 m contours.

MoT Section	1260	TAC Section	Not Applicable
-------------	------	-------------	----------------

1260.08 LINETYPE PATTERN DIMENSIONS

General

This section details the dimensions of the repeating patterns that make up the supplied linetypes. Each pattern is made up of one or more line segments (dashes) or points (dots) separated by empty space (gaps). Some linetypes include shapes or text as part of the repeating pattern.

The length of the pattern is determined by the lengths of the dashes and gaps. Shapes, text and dots do not contribute to the length. A pattern must start with either a dot or a dash.

Repeating the Pattern

AutoCAD repeats the pattern as many times as possible over the length of the polyline but will offset the pattern to ensure that the polyline always ends with a dot or a dash. As a result, the lengths of the line segments at the ends will usually be slightly longer or shorter than the pattern dimensions would indicate.

If a dot is used to start a linetype, AutoCAD will place a dot and a gap of varying length at the two ends of the polyline. The railway linetype starts with a dot and uses shapes (and gaps that are the length of the shapes) to simulate the appearance of parallel lines with solid filled areas. This pattern contains no dashes.

Patterning Around Vertices

Older versions of AutoCAD would restart the pattern at each vertex of a polyline. This would lead to a very uneven appearance with no pattern showing when the vertices were closer than the pattern length. Newer versions of AutoCAD allow linetype generation to be turned on. This setting should be turned on for each polyline that uses a linetype and will enable the pattern to proceed through the vertices.

Lettering or symbols near vertices may show artifacts as they are not able to change direction once started. Complex patterns such as the railway, barrier, hedge and wall linetypes are made up mostly of symbols and will therefore show noticeable errors if there are significant bends or a large number of vertices in the polyline.

Longer Patterns

A pattern that has very long dashes may be defined in a number of ways, for example:

- 30m dash , 2m gap, 6m dash, 2m gap
- 5m dash , 2m gap, 6m dash, 2m gap, 25m dash (effective dash length of 5m + 25m = 30m)

Both definitions result in 30m dashes as the pattern repeats. The second definition results in the 2m gaps moving much closer to the start of the line more clearly identifying the polyline as something other than a standard Continuous linetype.

Name, Description	Pattern Dimensions (metres) (l x w)
Alignment	
ALGN-BWL, Broken White Line	dash 5, gap 8
ALGN-BWL-CIRC, BWL - Roundabout Circulating Lane	dash 1, gap 1 (polyline width 0.2m)
ALGN-BWL-PUL, BWL - Bus Bay/Pullout	dash 1, gap 1
ALGN-BWL-RES, BWL - Reserved Lane	dash 6, gap 3

MoT Section	1260		TAC Section	Not Applicable
-------------	------	--	-------------	----------------

Name, Description	Pattern Dimensions (metres) (l x w)
ALGN-BWL-URB, BWL - Urban	dash 3, gap 6
ALGN-BWL-YIELD, BWL - Roundabout Yield Line	dash 0.6, gap 0.6 (polyline width 0.4m)
ALGN-CNTR, Centreline	dash 5, gap 2, dash 6, gap 2, dash 25 (effective dash 30m)
ALGN-DECL, Deceleration or Acceleration Lane	dash 3, gap 3
ALGN-DYL, Double Yellow Line	dash 5, gap 2, dash 6, gap 2, dash 25 (effective dash 30m)
ALGN-IGL, Intersection Guiding Line	dash 0.5, gap 0.5
ALGN-PATH, Path Tracker Linetype	dash 1, gap 1
ALGN-SHLD, Shoulder	dash 3, gap 2
ALGN-YL, Yellow Line	dash 5, gap 2, dash 6, gap 2, dash 25 (effective dash 30m)
Barriers	
BAR-CABLE, Cable Barrier with Posts	dash 5, sym, dash 10 (15m between symbols, 2m x 1.5m)
BAR-GUARD, Guard Rail with Posts	dash 5, sym, dash 10 (15m between symbols, 1.5m x 0.75m)
BAR-MB, Concrete Median Barrier - 2.5m	dot, five sub-symbols, gap 2.5 (2.5m x 0.6m barriers)
BAR-MB-L, Concrete Median Barrier - 2.5m (inside left)	same as above, centreline is left side of barrier
BAR-MB-R, Concrete Median Barrier - 2.5m (inside right)	same as above, centreline is right side of barrier
BAR-RB, Concrete Roadside Barrier - 2.5m	same as BAR-MB
BAR-RB-L, Concrete Roadside Barrier - 2.5m (inside left)	same as BAR-MB-L
BAR-RB-R, Concrete Roadside Barrier - 2.5m (inside rt)	same as BAR-MB-R
Construction	
CONST-BERM, Berm in Cut or Fill	dash 7, gap 3
CONST-CLGR, Clearing and Grubbing	dash 5, gap 5, dash 10 (effective dash 15m)
CONST-HOGF, Hog Fuel	dash 6, gap 6
CONST-RRAP, Riprap	dash 4, gap 3
CONST-STRIP, Stripping	dash 7, gap 2
CONST-WASTE, Waste	dash 5, gap 5

MoT Section	1260		TAC Section	Not Applicable
-------------	------	--	-------------	----------------

Name, Description	Pattern Dimensions (metres) (l x w)
Existing Features	
EXST-DIRTROAD, Dirt Road	dash 4, gap 2
EXST-FENCE, Fence	dash 5, gap 2.5, "X", dash 15, gap 2, dash 10 (1.8m text is centred in 2.5m gap, two 15m dashes)
EXST-GRAVEL, Gravel - G. Driveway, Edge of G., G. Road	dash 6, gap 2
EXST-RAIL, Railway	dot, ten sub-symbols, gap 10 (5m x 0.5m box, 5m x 0.5m filled)
EXST-RAILBALLAST, Railway Ballast	dash 15, gap 5
EXST-RESTAREA, Rest Area	dash 5, gap 4
EXST-ROAD, Road	dash 6, gap 2
EXST-TOE, Toe (Existing)	dash 6, gap 4
EXST-TREELINE, Hedge Line, Bush Line, Tree Line	dot, symbol, gap 2 (symbols are 2m x 1m, fills gap)
EXST-VEG, Garden, Lawn, Vegetation	dash 0.5, gap 2.5
Underground	
UG-DRAIN, Storm / Sewer Drain	dash 2.5, gap 2.4, "S", dash 15, gap 2, dash 12.5 (1.8m text is centred in 2.4m gap, two 15m dashes)
UG-ELEC, Underground Electrical Power	dash 2.5, gap 6, "UE", dash 15, gap 2, dash 12.5 (1.8m text is centred in 6m gap, two 15m dashes)
UG-GAS, Gas Main	dash 2.5, gap 2.571, "G", dash 15, gap 2, dash 12.5 (1.8m text is centred in 2.571m gap, two 15m dashes)
UG-MISC, Underground Miscellaneous	dash 2.5, gap 6.171, "UG", dash 15, gap 2, dash 12.5 (1.8m text is centred in 6.171m gap, two 15m dashes)
UG-OIL, Oil Line	dash 2.5, gap 7.371, "OIL", dash 15, gap 2, dash 12.5 (1.8m text is centred in 7.371m gap, two 15m dashes)
UG-PIPE, Pipeline (Not Plastic)	dash 5, gap 1
UG-PLASTIC, Pipeline (Plastic)	dash 4, gap 1
UG-SAN, Sanitary Sewer Line	dash 2.5, gap 9.086, "SAN", dash 15, gap 2, dash 12.5 (1.8m text is centred in 9.086m gap, two 15m dashes)
UG-TEL, Underground Telephone	dash 2.5, gap 5.657, "UT", dash 15, gap 2, dash 12.5 (1.8m text is centred in 5.657m gap, two 15m dashes)
UG-WATER, Water Main	dash 2.5, gap 3.429, "W", dash 15, gap 2, dash 12.5 (1.8m text is centred in 3.429m gap, two 15m dashes)

MoT Section	1260	TAC Section	Not Applicable
-------------	------	-------------	----------------

Name, Description	Pattern Dimensions (metres) (l x w)
Geotech	
GEO-TYPE-A, Type A - Solid Rock	dash 12.7, gap 6.35
GEO-TYPE-B, Type B - Over 50% Broken Rock	dash 6.35, gap 3.175
GEO-TYPE-C, Type C - Requires Ripping	dash 31.75, gap 6.35, dash 6.35, gap 6.35, dash 6.35, gap 6.35
GEO-WTE, Water Table Elevation (Estimated)	dash 0.1, gap 2.5, symbol, (four dash 5, gap 2.5), dash 4.9 (symbol 2m x 1.72m centered in 2.5m gap, five 5m dashes)
GEO-WTM, Water Table Elevation (Measured)	same as above with filled in symbol
Hydrology	
HYD-CNTR, Ditch, Creek or Stream Center	dash 5, symbol, gap 10, dash 5 (effective dash 10m) arrow is 5m x 0.8m, uses 5m of the 10m gap, effective gap 5m
HYD-DITCH, Ditch Edge	dash 8, gap 4
HYD-EW, Edge of Water	dash 2.5, gap 7.676, "HWM", dash 15, gap 2, dash 12.5 (1.3m text is centred in 7.676m gap, two 15m dashes)
HYD-HW, High Water Mark	dash 2.5, gap 6.343, "UT", dash 28.5 (1.8m text is centred in 6.343m gap, effective 31m dash)
HYD-HWE, High Water Mark (Extreme)	dash 0.5, gap 4.5
HYD-SEEP, Seepage	dash 0.5, gap 1
Lot Boundaries	
LOT-EA, Easement	dash 5, gap 5, dash 5 (effective dash 10m)
LOT-GB, Gazette Boundary	dash 5, gap 5, dash 10 (effective dash 15m)
LOT-IB, International Boundary	dash 5, gap 5, dash 5, gap 5, dash 5, gap 5, dash 30, gap 5
LOT-QS, Quarter Section Line	dash 5, gap 5, dash 25 (effective dash 30m)
LOT-RW, Right of Way	dash 5, gap 5, dash 30, gap 5, dash 5, gap 5
LOT-SL, Section Line / District Lot Boundary	dash 5, gap 5, dash 5, gap 5, dash 25 (effective dash 30m)
Toes	
TOES-BBEF, Base of Bridge End Fill	dash 2, gap 2
TOES-SHEX, Shoulder Excavation Start	dash 2, gap 2
TOES-TOE, Toe (Design)	dash 2, gap 2

MoT Section	1260	TAC Section	Not Applicable
-------------	------	-------------	----------------

Name, Description	Pattern Dimensions (metres) (l x w)
Topography	
TOPO-BSLP, Base of Slope or Embankment	dash 1, gap 1
TOPO-CRACK, Ground or Pavement Crack	dash 2, gap 1
TOPO-HORIZON-A, Type A Horizon	dash 4, gap 1, dash 1, gap 1, dash 1, gap 1
TOPO-MARSH, Marsh / Swamp	dash 6, gap 1
TOPO-ROCK, Solid Rock or Top of Rock	dash 4, gap 4
TOPO-SAND, Sand	dash 5, gap 3
TOPO-SLIDE, Slide, Scarp, Sluff Line	dash 16.5, sym, gap 5 (2m x 1.72m symbol centered on dash)
TOPO-TALUS, Talus, Broken or Loose R. or Base of Rock	dash 2, gap 2.75, dash 0.5, gap 2.75
TOPO-TRAIL, Trail - Mapping Requirement	dash 1, gap 1, dash 0.5, gap 1
TOPO-TSLP, Top of Slope or Embankment	dash 5, sym, dash 5, sym (short tick is 1.25m, long tick is 2.5m)
Walls	
WALL-DESIGN, Wall (Design)	dash 4, gap 4 (4m x 0.5m shape fills the gap)
WALL-EXIST, Wall (Existing)	dash 8, gap 4 (4m x 0.5m shape fills the gap)

MoT Section	1270	TAC Section	Not Applicable
-------------	------	-------------	----------------

1270 CAICE DESIGN PROJECT DATA FORMAT POLICY: TERMS OF REFERENCE

Table of Contents

1270	CAICE DESIGN PROJECT DATA FORMAT POLICY: TERMS OF REFERENCE	1270-1
1270.01	GENERAL	1270-2
1270.02	CAICE DESIGN PROJECT DATA FORMAT POLICY: EXCEPTIONS	1270-3
1270.03	CAICE DESIGN PROJECT DATA ARCHIVE: MISSING OR PROBLEM CONTENT	1270-5
1270.04	MINISTRY STANDARD LIBRARIES, TABLES, MACROS, FRAGMENTS	1270-5
1270.05	DESIGN PROJECT: FOLDERS AND ORGANIZATION	1270-6
1270.06	DESIGN PROJECT DATA ARCHIVE: PROJECT LOG FILES	1270-10
1270.07	DESIGN PROJECT DATA ARCHIVE: CDG FILES	1270-13
1270.08	DESIGN PROJECT DATA ARCHIVE: CONTENT AND NAMING CONVENTIONS	1270-15
1270.09	ZONE DESIGNATIONS	1270-64
1270.10	DESIGN PROJECT DATA ARCHIVE: PREPARATION	1270-66
1270.11	CONTRACT DRAWINGS	1270-68
1270.12	CONTRACT MATERIAL VOLUMES	1270-68
1270.13	DESIGN PROJECT ELECTRONIC DELIVERABLES: QUALITY CHECKLIST	1270-69

MoT Section	1270		TAC Section	Not Applicable
-------------	------	--	-------------	----------------

1270.01 GENERAL

The Ministry policy that all design contracts are to be completed in the specific format described in this document was officially applied October 1, 2003. All design contracts from that date forward must reference this section of the B.C. Supplement to TAC Geometric Design Guide.

The Ministry is implementing the CAiCE Design Project Data Format Policy for the following reasons:

1. The policy provides the Ministry with a standard format for all engineering data, regardless of whether Ministry staff or consultants complete the work.
2. The policy provides the opportunity for the Ministry to maintain a repository of engineering data that can be easily utilized in the future.
3. The common format will improve the flow of engineering data, eliminating the significant problems that have been experienced by Ministry construction supervision offices trying to utilize completed designs.

The CAiCE Design Project Data Format Policy: Terms of Reference has been developed through consultation with Ministry Field Services construction supervision staff, Ministry regional designers and Ministry/CEBC selected consultant designers.

Highway Project Lifecycle Definitions and CAiCE Deliverable Requirements

- *Needs Study (No CAiCE deliverable requirement)*

The identification of requirements for new or improved highways within the provincial highway network and/or municipal streets networks.

Reconnaissance Study (No CAiCE deliverable requirement)

A qualitative, high-level approach to identify all possible corridors between two specified nodes and to review the feasibility of each corridor. A single valley would be considered a corridor.

- *Corridor Study (No CAiCE deliverable requirement)*

A quantitative and qualitative evaluation to select a preferred corridor from a number of possible alternatives, or to identify the requirements for further study of selected corridors.

- *Route Study (No CAiCE deliverable requirement)*

The graphical development of accurate plans for all feasible locations of roads and/or configurations of interchanges/intersections, and their technical review.

- *Preliminary Design*

(CAiCE deliverable requirement if standalone design assignment)

To determine the ability of selected locations and configurations to meet the needs and requirements established in the previous stages, and recommend one for successive design stages.

- *Functional Design*

(CAiCE deliverable requirement if standalone design assignment)

The horizontal and vertical geometric design for the phase preceding the development of the final detailed design drawings.

MoT Section	1270		TAC Section	Not Applicable
-------------	------	--	-------------	----------------

- *Detailed Design (CAiCE deliverable requirement)*

The development of construction (contract) drawings and technical specifications for construction, including the completed geometric and geotechnical design, special site considerations and construction details.

- *Construction (CAiCE deliverable requirement)*

To standardize construction supervision practices and complete the detailed design based on construction original ground and the actual sub-surfaces un-earthed.

- *Post Construction (CAiCE deliverable requirement)*

To develop an As Built CAiCE DTM and As Built AutoCAD drawings for evidence in court, recording changes to a design during construction, background information when evaluating costs of further improvements.

The designer, depending on the project lifecycle phase, must submit a PRELIMINARY DESIGN , FUNCTIONAL DESIGN, DETAILED DESIGN and/or CONSTRUCTION archive(s) as detailed in [Section 1270.10 Design Project Data Archive: Preparation](#).

The PRELIMINARY, FUNCTIONAL and DETAILED DESIGN archives are required by the Ministry to retain an electronic record of design options/alternatives included in the contract design report. These options/alternatives will include anything shown to the public, municipal councils, and prepared as part of the environmental review process.

The CONSTRUCTION archive containing only the final design is required by the Ministry as a detailed record of the final design and to provide the necessary information for Ministry construction supervision purposes.

1270.02 CAICE DESIGN PROJECT DATA FORMAT POLICY: EXCEPTIONS

It is recognized that there are certain project situations where the CAiCE Design Project Data Format Policy will not apply. These specifically relate to design build projects and projects that meet specific exception criteria.

The policy exception criteria are presented below as a series of questions. If any one question is answered as **YES**, then the project must adhere to the CAiCE Design Project Data Format Policy. These questions should be answered through consultation with Ministry Field Services. Ministry Representative refers to Ministry Field Services or Ministry Field Services Consultant.

- Will the Ministry Representative have to provide survey layout?
- Will the Ministry Representative have to do earthwork quantity surveys or quality control surveys on survey layout?
- Will there be a requirement for the Ministry Representative to calculate any earthwork or gravel quantities from x-sections or DTM surface comparisons?
- Is the project an extension of, or in any way connected to an existing CAiCE project?
- Is data from other sources such as AutoCAD, design summaries etc. insufficient to provide the Ministry Representative with the detail necessary to administer the project?

MoT Section	1270		TAC Section	Not Applicable
-------------	------	--	-------------	----------------

The requirement for a DETAILED DESIGN archive will be determined by the Ministry design contract manager. This decision will be based on whether the completed design project will be immediately tendered for construction. If the completed design is expected to sit for a period of time for re-activation at some time in the future, then the DETAILED DESIGN archive will be a design contract requirement.

From past experience, when design projects have been completed but were not immediately tendered for construction, they were shelved for future use. Problems were often encountered when these design projects were re-activated and revisions were required prior to construction. Often the designer who originally completed the project was no-longer with the consulting firm and the original project knowledge was lost. The lack of a consistent standard for electronic design deliverables makes the re-activation of shelved designs more costly and time consuming.

Ministry design contracts will specify which of the four CAiCE Design Project Data Archives are required.

All Ministry of Transportation highway construction projects require the completion of an As Built CAiCE DTM and As Built AutoCAD drawings.

With the exception of design build projects, the As Built CAiCE DTM is completed by whoever is the Ministry Representative, be that Field Services or consultant doing the construction supervision. As Built AutoCAD drawings are prepared by the Engineer of Record responsible for the design.

A non design build project As Built CAiCE DTM is to be generated from the CAiCE design, incorporating any construction related design changes picked up by ground survey.

The As Built deliverable requirement also applies to all design build projects. For design build projects, the construction contractor completes the As Built deliverables and then has them certified by the Engineer of Record responsible for the design.

A design build project As Built CAiCE DTM can be generated from the CAiCE design or from a design completed in software other than CAiCE. The As Built CAiCE DTM is to incorporate any construction related design changes picked up by ground survey.

The reasoning behind the requirement for As Built deliverables are as follows:

- Used in court to establish that the highway was built in accordance with design criteria and that any changes that have occurred were a result of natural settlement, etc.
- Record changes to a design during construction accompanied by letters or reports indicating why the changes were implemented.
- Enable the Ministry to quickly evaluate costs on further improvements required to a recently constructed project.

MoT Section	1270		TAC Section	Not Applicable
-------------	------	--	-------------	----------------

1270.03 CAICE DESIGN PROJECT DATA ARCHIVE: MISSING OR PROBLEM CONTENT

The PRELIMINARY DESIGN, FUNCTIONAL DESIGN, DETAILED DESIGN and CONSTRUCTION CAiCE Design Project Data Archive files must contain the information specified in this section of the B.C. Supplement to TAC Geometric Design Guide as referenced by the Highway Design Contract Terms of Reference.

If a designer has failed to provide the complete error free CAICE Design Project Data Archive files, it is the full responsibility of the designer to resolve all omissions, deficiencies and errors in a timely manner. In the case of the CONSTRUCTION archive, it is imperative that there is no negative impact on the construction project schedule.

The Ministry will not be responsible financially for any extra work incurred by a consultant to resolve the identified omissions, deficiencies or errors when these Terms of Reference have not been followed.

1270.04 MINISTRY STANDARD LIBRARIES, TABLES, MACROS, FRAGMENTS

To assist consultants with the completion of CAiCE design work to Ministry standards, the Ministry provides all consultants with a complete set of standard libraries, tables, macros and fragments. These files are available for download from the Ministry's Public Website at the address shown below:

http://www.th.gov.bc.ca/publications/eng_publications/geomet/CAiCE/CAiCE.htm

The website is regularly updated as changes are made and Ministry installations are upgraded.

The Ministry provides technical support in the use of this material through the contact below, any other CAiCE software technical support should be directed to CAiCE at Autodesk as provided for, by a consultants annual subscription agreement.

Dale Francis
Manager, Business Analysis
Information Management Branch
Ministry of Transportation and Infrastructure
Email: Dale.Francis@gov.bc.ca

Ministry technical support for standard libraries, tables, macros and fragments should be requested by email as required.

MoT Section	1270	TAC Section	Not Applicable
-------------	------	-------------	----------------

1270.05 DESIGN PROJECT: FOLDERS AND ORGANIZATION

A CAiCE project folder can become very difficult to work with as a project grows and the number of project files increase. To improve the general organization of a CAiCE project deliverable, designers are required to implement the following folder structure:

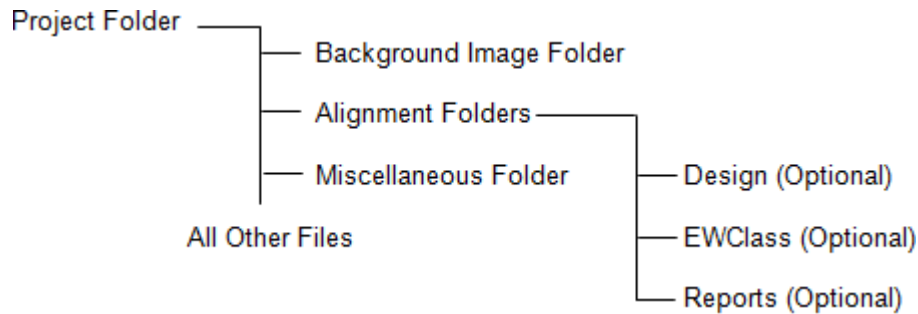

Sample (project name is RDWKSP):

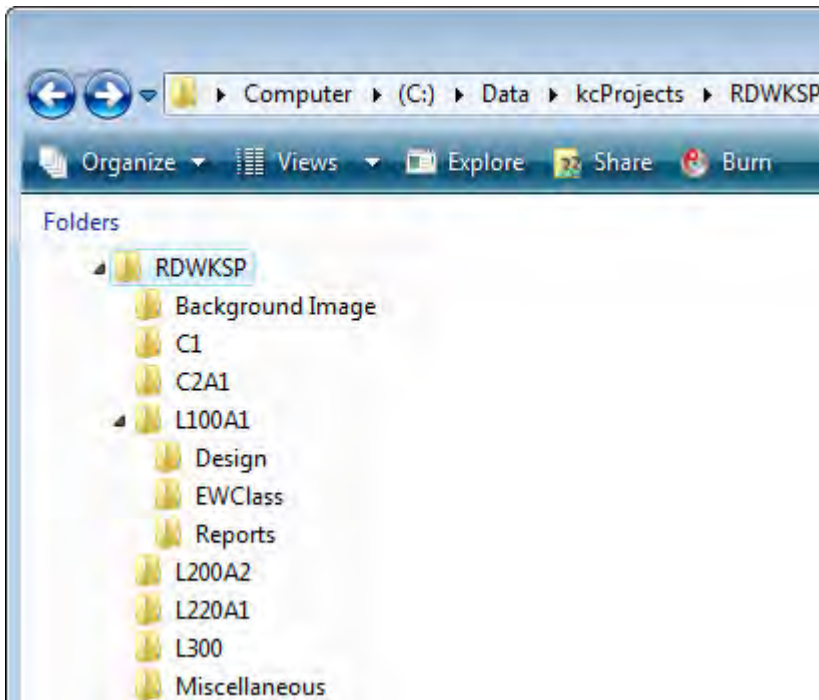

MoT Section	1270		TAC Section	Not Applicable
-------------	------	--	-------------	----------------

Background Image Folder

Archive Requirement

- Preliminary Design – Yes
- Functional Design – Yes
- Detailed Design – Yes
- Construction – Yes

A Background Image folder will contain only the AutoCAD DWG and Microstation DGN (Trim Mapping) background image files optionally created for use with the design.

Alignment Folders

Archive Requirement

- Preliminary Design – Yes
- Functional Design – Yes
- Detailed Design – Yes
- Construction – Yes

Individual Alignment folders are to contain files that directly relate to the alignment named in the Alignment folder name. Separate folders must be created for the mainline, minor, sideline and access/intersection curve horizontal alignments. Optional Alignment folder sub-folders “Design”, “EWClass” and “Reports” can be added by the designer to assist with the organization of project files if so desired. Alignment folder names should not be defined using special characters. Typical files that should be placed under the Alignment folder are as follows:

Required:

CDG	CAiCE Drawing Graphics Files
EAR	Base Cross Section and Design Cross Section Files
ERP	End Area Report Files
LIS	List Files
PF\$	Terrain Profiles
PXS	Draw X-Section macro Parameter File
PPF	Draw Profile Sheets macro Parameter File
RPT	Report Files
RTF	Rich Text Format Documents
TBL	Alignment Specific Tables (e.g.: Earthwork Classification Table)
VRB	Design VRS Backup Files
VRS	Design Files

Required if created:

X#%	Edit Area Attributes Manual Material Envelope Definition
XCP	Advanced End Areas / Volumes Exception Station Details
XLS	Excel Spreadsheet Files
DOC	Word Documents
ER2	Advanced End Areas / Volumes Exception Station Data Report
INI	Alignment Specific Parameter Files
LOG	Log Files
TXT	Text Files

MoT Section	1270		TAC Section	Not Applicable
-------------	------	--	-------------	----------------

If optional Alignment folder sub-folders are to be used, then typical files that should be placed under the main alignment folder and its sub-folders are as follows:

Main Alignment Folder

Required:

CDG	CAiCE Drawing Graphics Files
EAR	Base Cross Section Files
PF\$	Terrain Profiles
PXS	Draw X-Section macro Parameter File
PPF	Draw Profile Sheets macro Parameter File
TBL	Alignment Specific Tables

Required if created:

INI	Alignment Specific Parameter Files
TXT	Text Files

Design Sub-folder

Required:

EAR	Design Cross Section Files
VRB	Design VRS Backup Files
VRS	Design Files

Required if created:

X#%	Edit Area Attributes Manual Material Envelope Definition
XCP	Advanced End Areas / Volumes Exception Station Details

EWClass Sub-folder

TBL	Alignment Specific Earthwork Classification Tables
-----	--

Reports Sub-folder

Required:

ERP	End Area Report Files
LIS	List Files
RPT	Report Files
RTF	Rich Text Format Documents

Required if created:

DOC	Word Documents
ER2	Advanced End Areas / Volumes Exception Station Data Report
LOG	Log Files
XLS	Excel Spreadsheet Files

MoT Section	1270		TAC Section	Not Applicable
-------------	------	--	-------------	----------------

Miscellaneous Folder

Archive Requirement

- Preliminary Design – Yes
- Functional Design – Yes
- Detailed Design – Yes
- Construction – Yes

A Miscellaneous Folder will contain designer created files that do not relate to a specific horizontal alignment. Typical files that could be placed in this folder are shown below and potentially files shown above, if they are common to multiple alignments:

Required:

CCL	Project Specific Cell File
CDG	CAiCE Drawing Graphics Files
FTB	Project Specific Feature Table
LIS	List Files
RPT	Report Files
RTF	Rich Text Format Documents
TBL	Tables (e.g.: Non-Alignment Specific Earthwork Classification Table)

Required if created:

DOC	Word Documents
INI	Parameter Files
LOG	CAiCE Design Project Log Files
TXT	Text Files
XLS	Excel Spreadsheet Files
PXS	Draw X-Section macro Parameter File
PPF	Draw Profile Sheets macro Parameter File

MoT Section	1270	TAC Section	Not Applicable
-------------	------	-------------	----------------

1270.06 DESIGN PROJECT DATA ARCHIVE: PROJECT LOG FILES

Archive Requirement

- Preliminary Design – Yes
- Functional Design – Yes
- Detailed Design – Yes
- Construction – Yes

The designer must create and maintain a Design Project Data Archive Project Log File for each of the design assignment phases, Preliminary Design, Functional Design, Detailed Design and Construction Supervision, depending on the phase that is being completed under contract.

To establish a standard for the creation of all Design Project Data Archive Project Log Files, the Ministry has developed the CAiCE Design Project Data Archive Log File Generator macro that will generate a basic log file Excel spreadsheet.

It should be noted that the successful use of the CAiCE Design Project Data Archive Log File Generator macro depends on strict adherence to the project data archive naming conventions detailed in the following sections:

- [1270.05 Design Project: Folders and Organization](#)
- [1270.07 Design Project Data Archive: CDG Files](#)
- [1270.08 Design Project Data Archive: Content and Naming Conventions](#)

Macro Dialogue Box #1

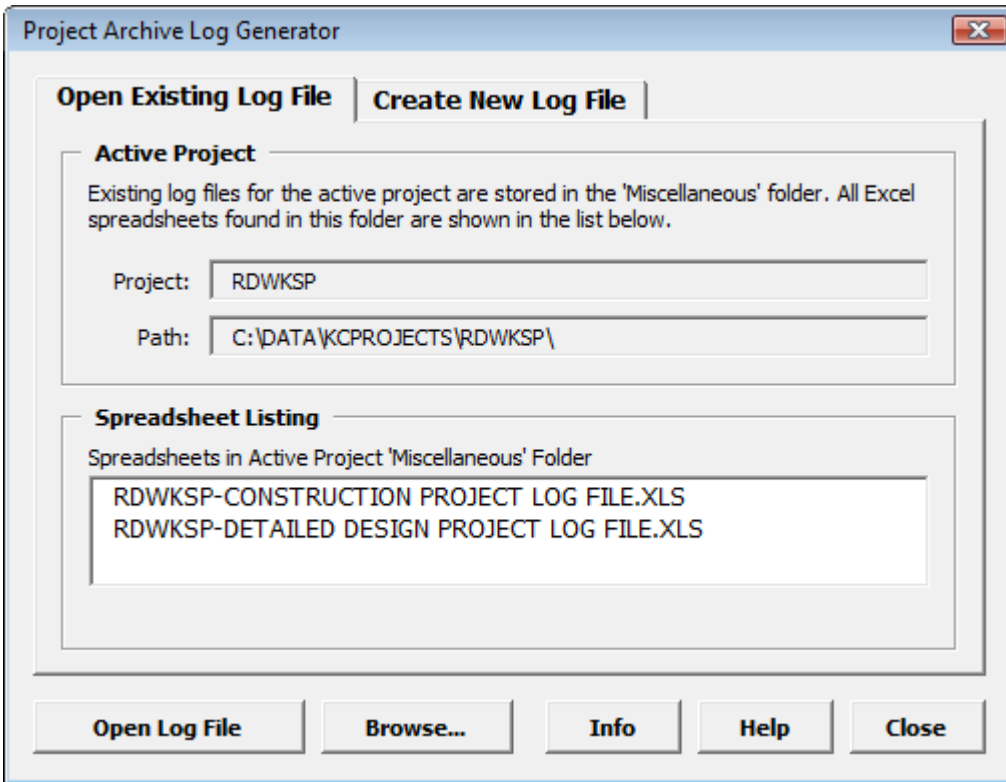

Macro dialogue box #1 displays the current CAiCE project and drive/folder path. The designer may open an existing log file spreadsheet or click the “Create New Log File” tab near the top of the dialog.

MoT Section	1270	TAC Section	Not Applicable
-------------	------	-------------	----------------

Macro Dialogue Box #2

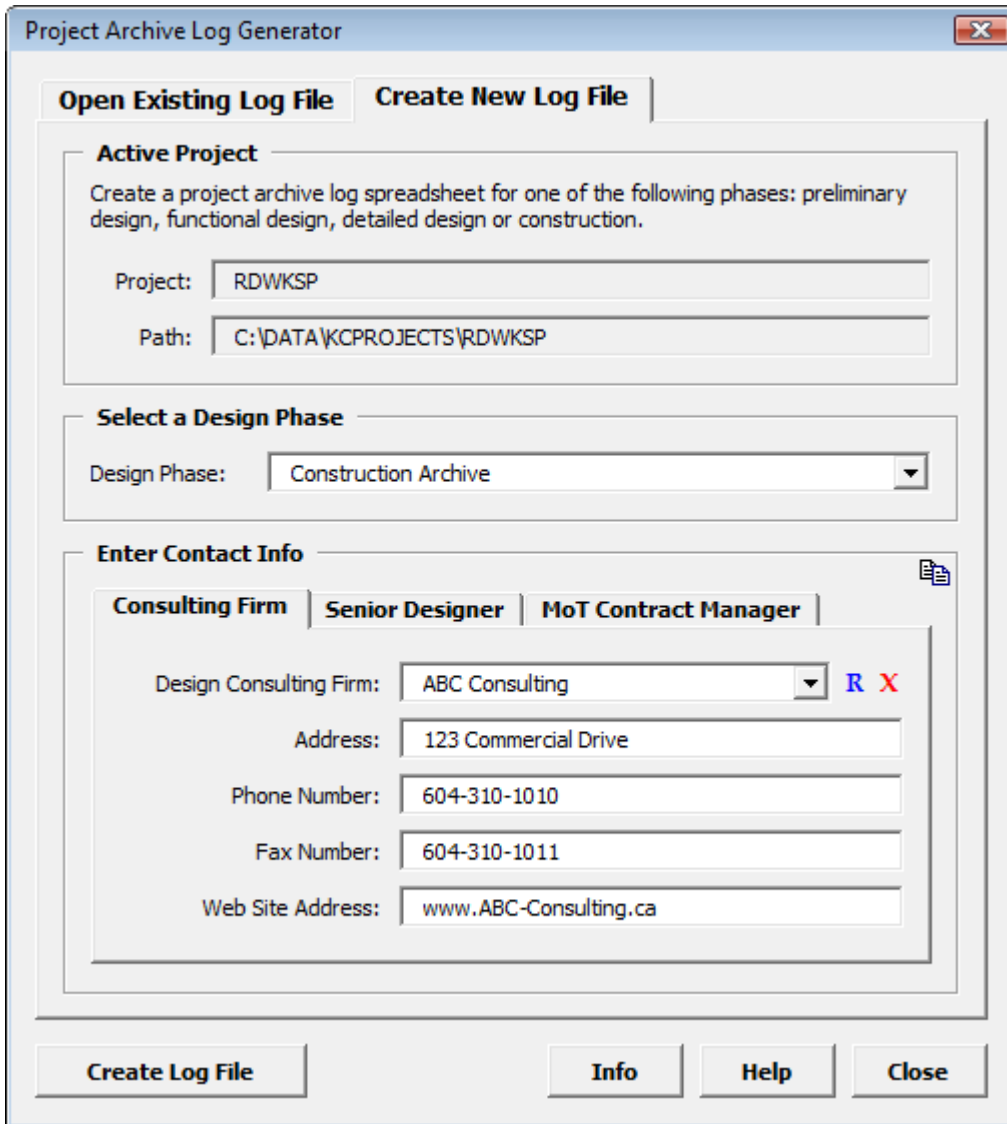

Macro dialogue box #2 displays the current CAiCE project and drive/folder path. The designer selects the Preliminary Design, Functional Design, Detailed Design or Construction Archive as a basis for the creation of the project log file spreadsheet.

The designer enters consulting firm, senior designer and MoT contract manager contact information to be added to the spreadsheet. This information is saved with the project for future use and may be copied from another project using the copy icon at the upper right of the “Enter Contact Info” area.

The macro, using this basic input from the designer will populate the log file spreadsheet with project data identification and descriptions found in the CAiCE project. The “Info” button describes this process in detail and may provide useful information as to why items are (or are not) included in the spreadsheet.

The designer must then add information to the basic log file spreadsheet as required, appropriately describing the contents of the CAiCE Design Project Data Archive.

MoT Section	1270		TAC Section	Not Applicable
-------------	------	--	-------------	----------------

The log file spreadsheet defines how all CAiCE project files and database elements relate to one another with their relevant descriptions. The macro populates the spreadsheet as intelligently as possible, but it is up to the designer to finalize it, to meet the specific requirements of the CAiCE Design Project Data Archive Log File.

If the macro is unable to positively identify and assign a specific CAiCE project file or database element with a horizontal alignment or profile, then the spreadsheet entry is assigned an identifier ***LFEVR*** (log file entry verification required). In this situation, it is up to the designer to review this specific file or database element and decide whether it should be left in its current location in the spreadsheet, moved or removed.

If the macro is unable to find a description associated with a CAiCE database element, or it is dealing with a file, then the spreadsheet entry is assigned an identifier ***UDDR*** (user defined description required). In this situation, it is up to the designer to add an appropriate description or remove the CAiCE database element or file.

The macro provides the ability to append data to an existing log file spreadsheet so that any descriptions and or comments that are added or revised during a previous log file spreadsheet generation will be maintained. Additions and/or revisions to the spreadsheet should be limited to spreadsheet column E otherwise the ability to append to a previously generated spreadsheet may result in difficulties. The append capability does not apply to rows removed from a previously generated log file spreadsheet or moved to a different location in the spreadsheet. For these situations, these same rows would have to be moved and/or removed the next time the spreadsheet is generated.

The spreadsheet and its user defined descriptions, in combination with the contract Preliminary, Functional or Detailed Design Report, must provide sufficient detail to allow anyone reviewing the project to understand why a project phase has evolved the way it has. This is to include a record of what has been provided to the public and municipal councils, prepared as part of the environmental review process and what follow-up actions have taken place.

Specifically related to the Construction project log file, the designer must include details on issues that may warrant special attention during construction. The log file must be used to record details of the final design sufficient to allow construction supervision staff to understand methods and how the final design is pulled together. Entries in the log file must be as descriptive as possible to limit the amount of contact needed between construction supervision staff and the designer as the final design data is utilized. Basically, if the designer is making some sort of addition or revision that directly relates to the use of the final design data, then it should be documented in the project log file. Below are a few examples of what log file descriptions should include, but do not necessarily cover all potential additions:

- Base cross section file descriptions including a description of the DTM surfaces used and stratum surfaces present in the file.
- Cross section station text file descriptions indicating any geometry chains used to limit x-section scanline widths.

The Design Project Data Archive Log File Generator macro creates the log file spreadsheet in the project Miscellaneous folder using the following naming convention prefixed by the project name:

```
@@@@@-PRELIMINARY DESIGN PROJECT LOG FILE.XLS
@@@@@-FUNCTIONAL DESIGN PROJECT LOG FILE.XLS
@@@@@-DETAILED DESIGN PROJECT LOG FILE.XLS
@@@@@-CONSTRUCTION PROJECT LOG FILE.XLS
```

MoT Section	1270		TAC Section	Not Applicable
-------------	------	--	-------------	----------------

1270.07 DESIGN PROJECT DATA ARCHIVE: CDG FILES

Design project data archive CDG files provide construction supervision staff and anyone else wishing to review the project data, a very easy method of producing views of all design elements that directly relate to the major, minor, sideline and access/intersection curve horizontal alignments.

Separate CDG files must be created for the major, minor, sideline and access/intersection curve horizontal alignments with associated detail. For example the CDG files generated for the major L100A1 horizontal alignment would include the following detail:

L100A1 PLAN CDG File

Archive Requirement

- Preliminary Design – No
- Functional Design – Yes
- Detailed Design – Yes
- Construction – Yes

- All related survey points (with cells) and survey chains (with patterning)
- All related AutoCAD DWG background image files
- All related Trim Mapping DGN background image files

L100A1 GEOMETRY CDG File

Archive Requirement

- Preliminary Design – No
- Functional Design – Yes
- Detailed Design – Yes
- Construction – Yes

- Major horizontal alignment L100A1
- All related ditch horizontal alignments D10, D11, D12, etc.
- All related structure horizontal alignments S20, S21, S22, etc.
- All related design fragment application geometry chains 100PSHR65, 100PLEL79, etc.
- All 3D driveway chains (CAiCE survey chains) 100PDWR117, 100PDWL57, etc.
- All related right of way geometry chains PRW43, PRW57, etc.
- All related temporary license for construction access geometry chains PTLCA32, PTLCA46, etc.
- All related clearing and grubbing geometry chains PCLGR18, PCLGR23, etc.
- All related cut/fill toe geometry chains 100PTCL23, 100PTFR43, 100PTOL76, etc.
- All related vertical cutoff geometry chains 100PVCL12, 100PVCR27, etc.
- All gutter geometry chains 100PGUR87, 100PGUL99, etc.
- All back of sidewalk (outermost) geometry chains 100PSWR14, 100PSWL53, etc.
- All barrier (not controlled by edge of pavement) geometry chains 100PNEB34, 100PNEB147, etc.
- All island curb (curb and pavement intersect) geometry chains 100PIC47, 100PIC253, etc.
- All asphalt curb (curb and pavement intersect) geometry chains 100PAC47, 100PAC253, etc.
- All raised median curb (curb & pavement intersect) geometry chains 100PRMC48, 100PRMC254, etc.
- All concrete median centre divider (curb and pavement intersect) geometry chains 100PMC26, etc.
- All related geometry chains not identified above

MoT Section	1270	TAC Section	Not Applicable
-------------	------	-------------	----------------

L100A1 PROFILES CDG File

Archive Requirement

- Preliminary Design – No
- Functional Design – Yes
- Detailed Design – Yes
- Construction – Yes

- All related profiles L100A1P1 etc.
- All related design fragment application profiles 100PDCR75, 100PBEL88, etc.

L100A1 UNDERGROUND CDG File

Archive Requirement

- Preliminary Design – No
- Functional Design – No
- Detailed Design – Yes
- Construction – Yes

- All related storm drain / storm sewer line pipe geometry chains PDS25, PDS342, etc.
- All related sanitary sewer line pipe geometry chains PSU13, PSU134, etc.
- All related water line pipe geometry chains PWR17, PWR589, etc.

The basic design project data archive CDG file naming convention that must be used is to prefix the name with the horizontal alignment followed by one of four descriptive names (PLAN, GEOMETRY, PROFILES or UNDERGROUND) that describe the graphics snapshot of that specific aspect of the project.

L100A1 PLAN.CDG

L100A1 GEOMETRY.CDG

L100A1 PROFILES.CDG

L100A1 UNDERGROUND.CDG

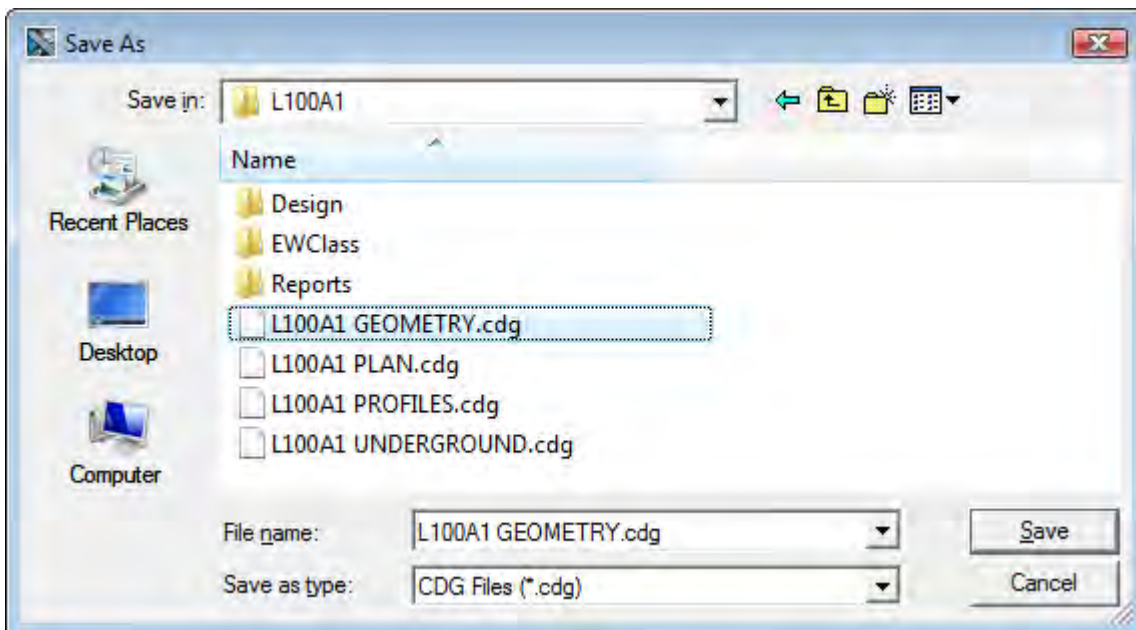

MoT Section	1270	TAC Section	Not Applicable
-------------	------	-------------	----------------

1270.08 DESIGN PROJECT DATA ARCHIVE: CONTENT AND NAMING CONVENTIONS

Many CAiCE database elements and files are required to complete the design project. These requirements are detailed throughout this section. As the CAiCE design project progresses, without the implementation of the strict naming conventions detailed in this section, it would be very difficult for anyone apart from the designer to review and work with the completed project.

To improve the general use of completed CAiCE design projects, designers must provide the following design project data archive content and follow the required CAiCE database element and file naming conventions.

CAiCE Project Name

Archive Requirement

- Preliminary Design – Yes
- Functional Design – Yes
- Detailed Design – Yes
- Construction – Yes

CAiCE project names can be created to a maximum of 7 characters. The CAiCE project name chosen must reflect the name of the design project as much as possible within the 7 character limit. The Ministry may choose to assign the CAiCE project name and if so, it will appear in the design contract terms of reference.

Design Project Specific Feature Table and Cell Library File

Archive Requirement

- Preliminary Design – Yes
- Functional Design – Yes
- Detailed Design – Yes
- Construction – Yes

The Ministry Standard BC Global Feature Table file and BC Global Cell Library file must be copied to the project Miscellaneous folder for use with the project. If the designer has the requirement to make modifications, the feature table file and/or cell library file must be renamed so that it reflects the project as shown in the example below:

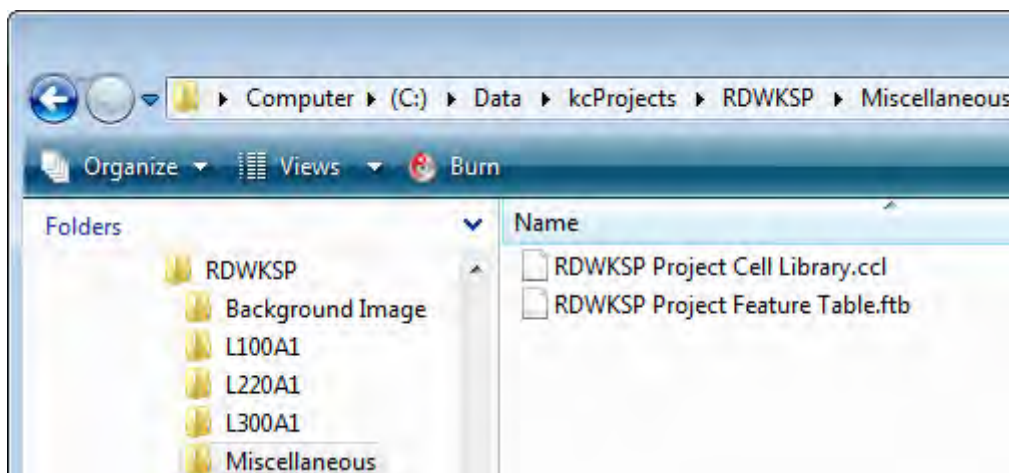

MoT Section	1270		TAC Section	Not Applicable
-------------	------	--	-------------	----------------

Project Cadastral

Archive Requirement

- Preliminary Design – Yes
- Functional Design – Yes
- Detailed Design – Yes
- Construction – Yes

The designer must provide AutoCAD DWG background image files generated as part of the completed survey project that can be used to display the project cadastral while working within CAiCE. These are to be saved in the CAiCE project Background Image folder.

The basic CAiCE project cadastral file naming convention that must be used is to prefix the file name(s) with “CADASTRAL”.

CADASTRAL @@@@.DWG

Plan Detail

Archive Requirement

- Preliminary Design – No
- Functional Design – Yes
- Detailed Design – Yes
- Construction – Yes

The designer must provide AutoCAD DWG and Microstation DGN (Trim Mapping) background image files optionally created for use with the design. These files may have been generated as part of the completed survey project or as a supplement to the survey during the design process.

The basic CAiCE Project Plan Detail file naming convention that must be used is to prefix the file name(s) with “PLAN DETAIL”.

PLAN DETAIL @@@@.DWG

PLAN DETAIL @@@@.DGN

MoT Section	1270		TAC Section	Not Applicable
-------------	------	--	-------------	----------------

CAiCE Database Element and File Naming Descriptions

Archive Requirement

- Preliminary Design – Yes
- Functional Design – Yes
- Detailed Design – Yes
- Construction – Yes

Generally most of the CAiCE database elements provide an input field for description. The designer should make full use of these input fields, if there is additional information needed to describe an element beyond what is required by the element naming conventions described in this section. The designer should make full use of long file naming when creating files within a CAiCE project. Descriptions and file names can contain such things as alignment references, DTM names, stations, dates, links to other files, etc.

Horizontal Alignment Geometry Chains

The purpose of implementing naming conventions for horizontal alignments is to ensure that all alignments have **unique names and stationing**, therefore reducing any chance of confusion.

Contract drawings that represent horizontal alignments must have the horizontal alignment names match the names used within the CAiCE design project. This will ensure consistency between CAiCE designs and the resulting contract drawings.

A CAiCE horizontal alignment geometry chain has a 10 character limit. Working within this limit, designers must now implement the following database element naming conventions:

L100 – Major Alignment

Archive Requirement

- Preliminary Design – Yes
- Functional Design – Yes
- Detailed Design – Yes
- Construction – Yes

This is the basic naming convention for horizontal alignments where there are no design alternatives being considered. The start station of the L100 alignment would be 100+00 or 100+000 for very long alignments.

MoT Section	1270		TAC Section	Not Applicable
-------------	------	--	-------------	----------------

L100A1, L100A2, L100A3 etc. – Major Alignment Alternatives

Archive Requirement

- Preliminary Design – Yes
- Functional Design – Yes
- Detailed Design – Yes
- Construction – Yes

This is the basic naming convention for a horizontal alignment where different design alternatives are being considered.

L200, L225, L250, L275, L300 etc. – Minor or Sideline Horizontal Alignments

Archive Requirement

- Preliminary Design – Yes
- Functional Design – Yes
- Detailed Design – Yes
- Construction – Yes

This is the basic naming convention for a horizontal alignment defining minor alignments or sidelines. The start station of these alignments would be the same as the convention used for a major alignment. The start station of the L200 alignment would be 200+00 or if the station format has been changed on the major alignment to accommodate an extra long alignment then 200+000. The start station of the L225 alignment would be 225+00 or if the station format has been changed on the major alignment to accommodate an extra long alignment then 225+000.

The designer must ensure that stationing being used on a minor or sideline horizontal alignment is unique to that alignment. If there is any chance of a stationing overlap, for example with stationing on alignment L200 overlapping stationing on alignment L225, then the alignment L225 should not be used and the higher alignment name used such as L300.

C1, C2, C3 etc. – Access/Intersection Curve Horizontal Alignments (Curb Return)

Archive Requirement

- Preliminary Design – No
- Functional Design – No
- Detailed Design – Yes
- Construction – Yes

There will be no requirement for access/intersection curve horizontal alignments in situations where the curve radius is less than 10 metres and/or the length of horizontal alignment would be less than 20 metres. Beyond these criteria, access/intersection curve horizontal alignments and associated details are required unless otherwise specified through consultation with Ministry Field Services.

This is the basic naming convention for a access/intersection curve horizontal alignment. The start station of these access/intersection curve horizontal alignments would be the same as the convention used for a minor alignment or sideline. The designer must ensure that the stationing being used on the access/intersection curve horizontal alignment is unique to that access/intersection curve for the same reasons described above for minor and sideline horizontal alignments.

MoT Section	1270		TAC Section	Not Applicable
-------------	------	--	-------------	----------------

D10, D11, D12 etc. – Ditch Horizontal Alignments

Archive Requirement

- Preliminary Design – No
- Functional Design – No
- Detailed Design – Yes
- Construction – Yes

This is the basic naming convention for a ditch horizontal alignment. The start station of these ditches would be the same as the convention used for a minor or sideline horizontal alignment. The designer must ensure that the stationing being used on the ditch horizontal alignment is unique to that ditch for the same reasons described above for minor and sideline horizontal alignments.

S20, S21, S22, etc. – Structure Horizontal Alignments

Archive Requirement

- Preliminary Design – No
- Functional Design – Yes
- Detailed Design – Yes
- Construction – Yes

This is the basic naming convention for a structure horizontal alignment. The start station of these structures would be the same as the convention used for a minor or sideline horizontal alignment. The designer must ensure that the stationing being used on the structure horizontal alignment is unique to that structure for the same reasons described above for minor and sideline horizontal alignments.

Horizontal Alignment Elements – Points, Curves, Spirals, Spiral Curve Spirals

Archive Requirement

- Preliminary Design – Yes
- Functional Design – Yes
- Detailed Design – Yes
- Construction – Yes

The basic horizontal alignment element naming conventions that must be used are what have been defined by the Ministry standard CAiCE object defaults. The object defaults are found in CAiCE using the **Settings → Object Defaults** command.

MoT Section	1270	TAC Section	Not Applicable
-------------	------	-------------	----------------

Points – HGPNT

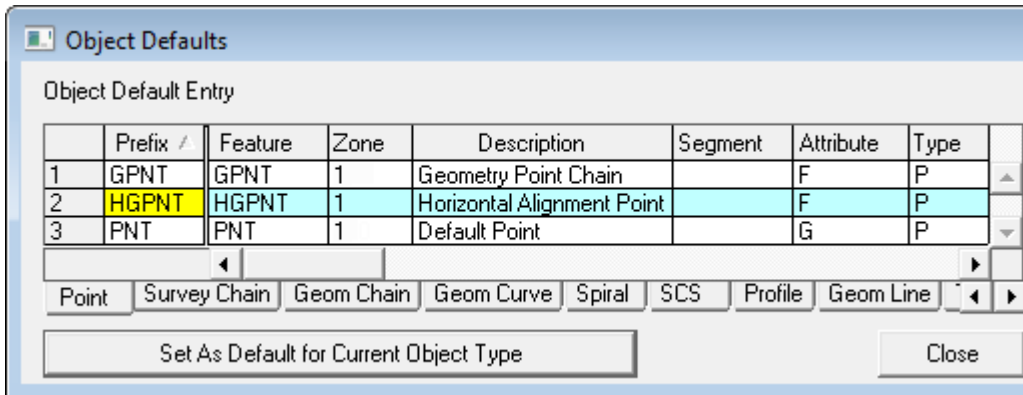

Spirals – SPRL

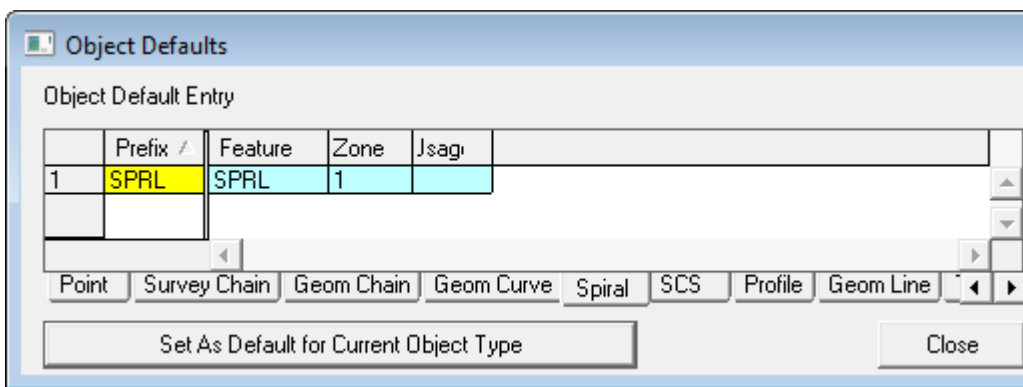

Spiral Curve Spiral – SCS

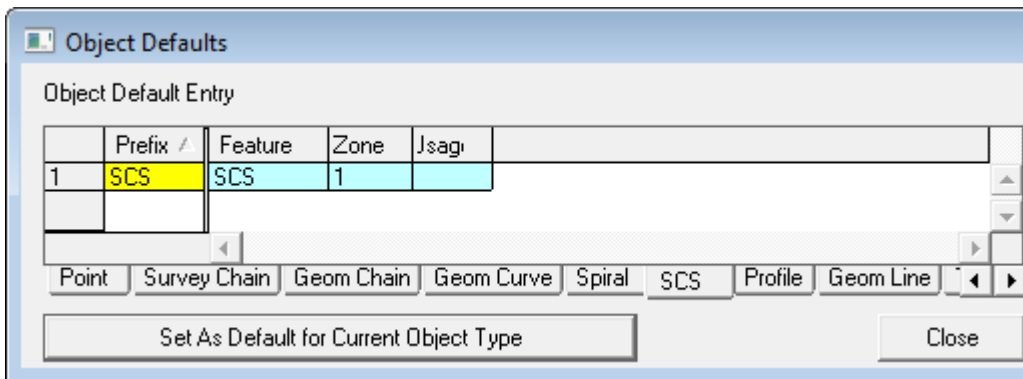

Curves – CURV

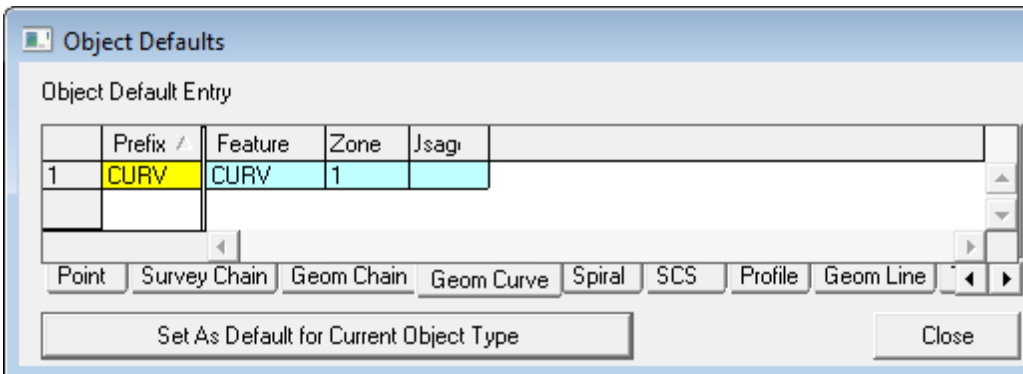

MoT Section	1270	TAC Section	Not Applicable
-------------	------	-------------	----------------

Design Element Feature Codes

Archive Requirement

- Preliminary Design – Yes
- Functional Design – Yes
- Detailed Design – Yes
- Construction – Yes

If it has not been specified elsewhere in this document, design element feature codes must be applied as set out in the project object defaults for such elements as profiles, horizontal alignments etc.

Superelevation Lines

Archive Requirement

- Preliminary Design – No
- Functional Design – Yes
- Detailed Design – Yes
- Construction – Yes

The superelevation line element prefix must include the Horizontal Alignment Name followed by SE. The letter “L” may be dropped if there is a requirement for more than 99 superelevation lines on a specific horizontal alignment.

L100A1SE or 100A1SE

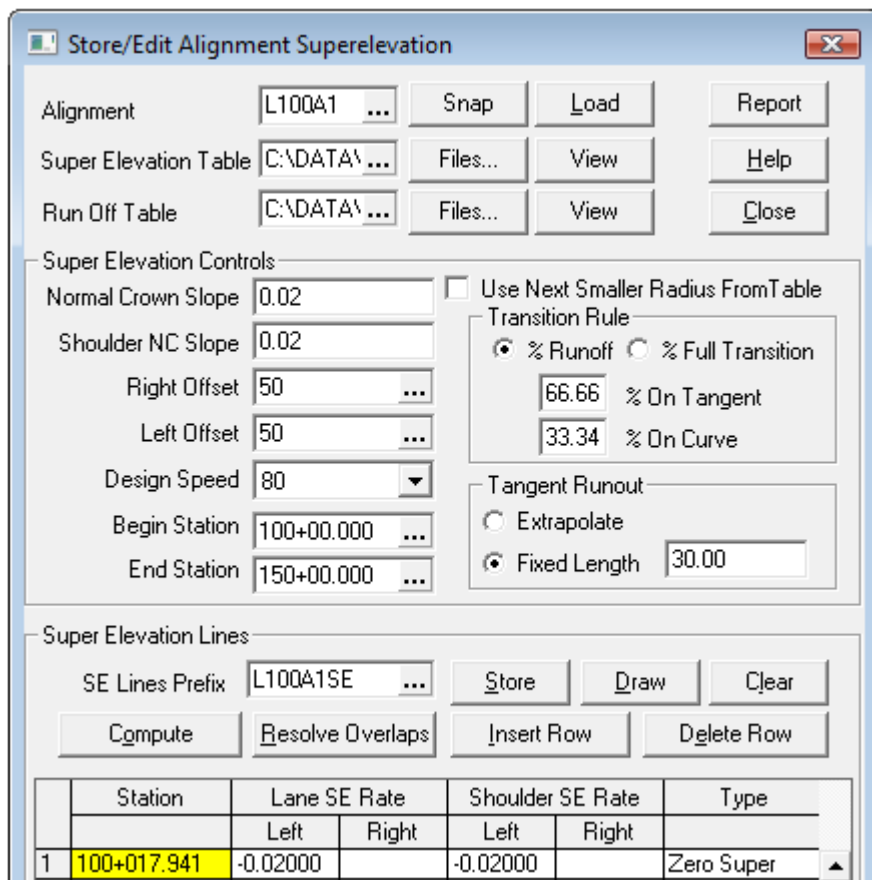

MoT Section	1270		TAC Section	Not Applicable
-------------	------	--	-------------	----------------

Cross Section Stations Text Files

Archive Requirement

- Preliminary Design – No
- Functional Design – Yes
- Detailed Design – Yes
- Construction – Yes

The designer must create and maintain cross section stations text files that may be required to generate cross section scanlines. The files must include station intervals and individual stations such as those shown below:

Functional Design

- Station interval maximum of 20m
- Any other miscellaneous odd stations generated and used by the designer

Detailed Design

- All roadway width change stations
- All crossfall/superelevation change stations
- All roadway template change stations – gravel, ditch widths, slopes, etc.
- All vertical alignment high and low point break stations
- Station Intervals that reflect material types, 5m, 10m, 20m, etc. A maximum 10 metre interval is to be used unless otherwise specified through consultation with Ministry Field Services.
- Any other miscellaneous odd stations generated and used by the designer in the calculation of final design volumes.
- All horizontal alignment curve and spiral transition stations
- All contract drawing spot elevation locations
- All structure stations – bridge abutments, retaining walls, etc. A maximum 5 metre interval is to be used unless otherwise required by the structure design. Bridge and wall drawings on the following pages provide an indication of the cross section stations that are required for structure situations.

Structure stations are not required if structure construction is to be paid for by facial area or by an all inclusive cost. In these situations, cross section stations are still required at 5 metre intervals for approximate wall structure excavation and backfill quantity calculations used for project tender reference purposes.

MoT Section	1270	TAC Section	Not Applicable
-------------	------	-------------	----------------

Detailed Design Cont.

- All structure stations – cont.

Plan View of Cross Section Locations at Skewed Bridge Abutments

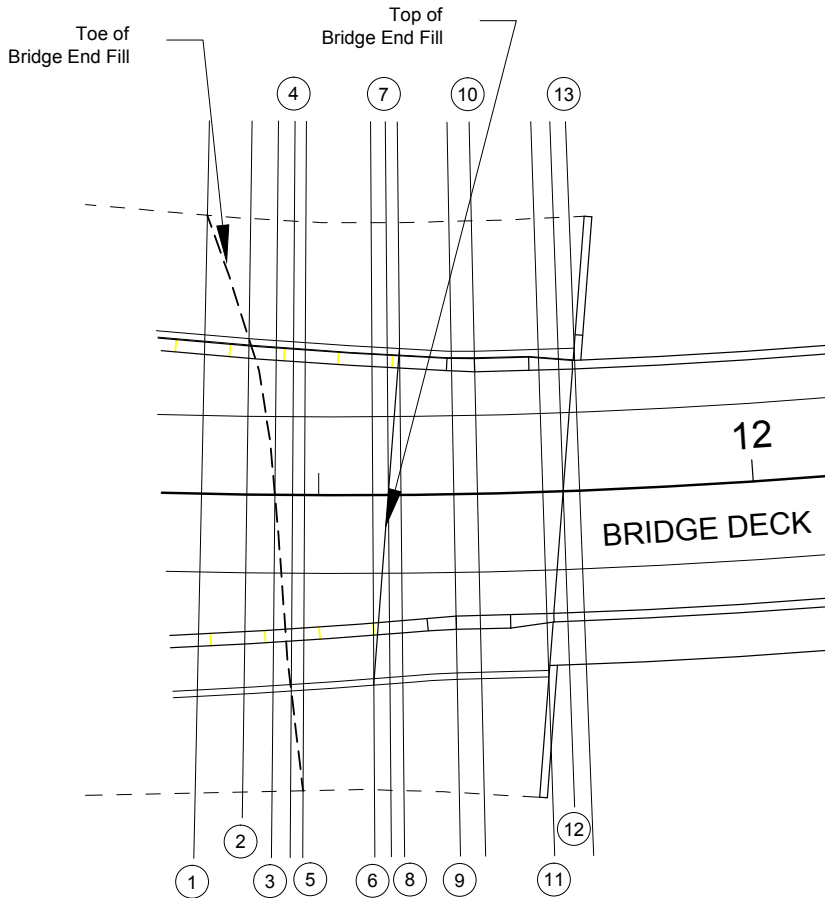

1. Intersection of left toe with chain from site design (toe of endfill)
2. Intersection of left gravel shoulder with chain from site design (toe of endfill)
3. Intersection of centerline with chain from site design (toe of endfill)
4. Intersection of right gravel shoulder with chain from site design (toe of endfill)
5. Intersection of right toe with chain from site design (toe of endfill)
6. Intersection of offset from back of abutment (top of endfill) with right gravel shoulder.
7. Intersection of offset from back of abutment (top of endfill) with centerline.
8. Intersection of offset from back of abutment (top of endfill) with left gravel shoulder.
9. End of CRB flare taper right.
10. End of CRB flare taper left.
11. Intersection of gravel shoulder with back of bridge abutment right.
12. Intersection of centerline with back of bridge abutment.
13. Intersection of gravel shoulder with back of bridge abutment left.

MoT Section	1270	TAC Section	Not Applicable
-------------	------	-------------	----------------

Detailed Design Cont.

- All structure stations – cont.

Additional cross sections should be extracted at the ends of wing walls, bends in wing walls etc.

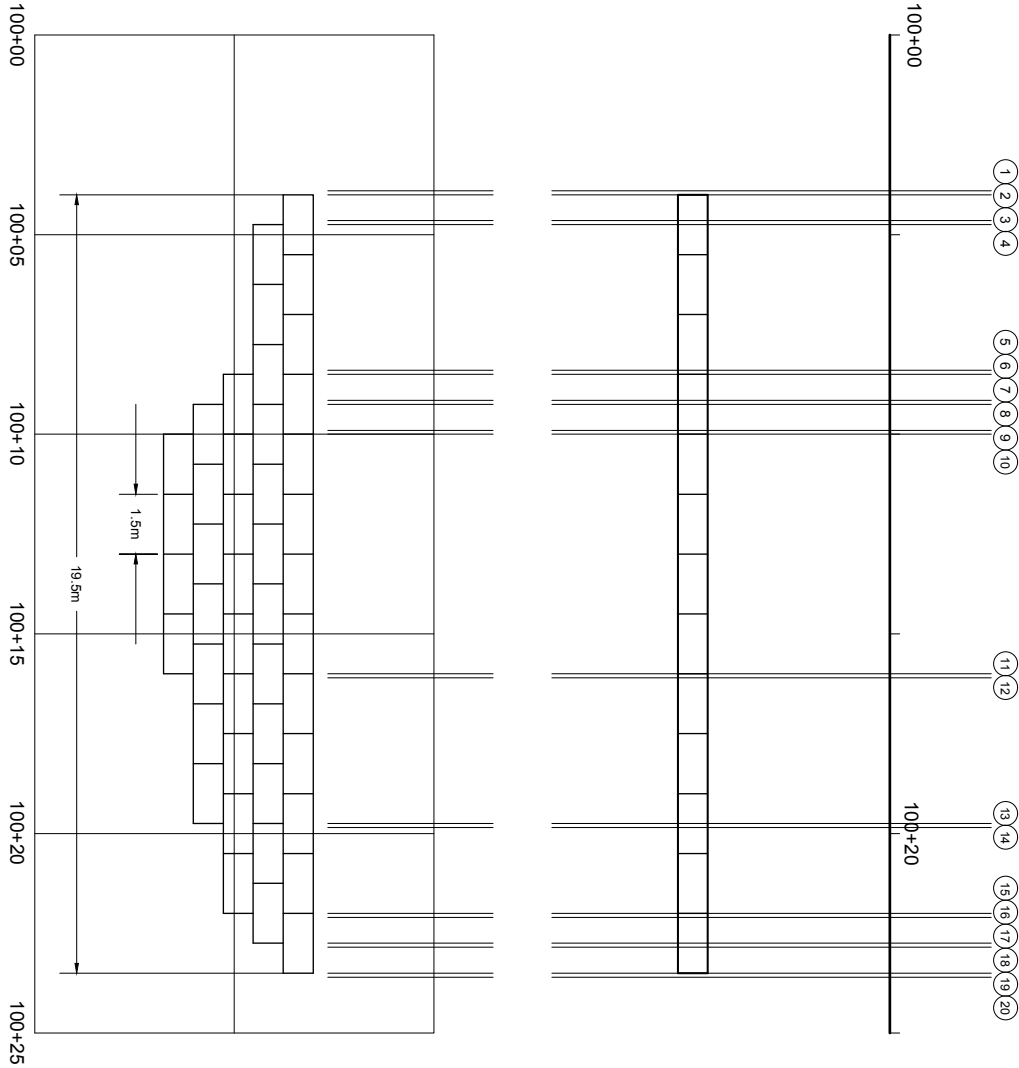

CROSS-SECTION STATIONS AT WALLS

5m INCREMENTS ALONG WALL BEGINNING AND END STATIONS OF WALL BEGINNING AND END STATIONS OF ANY STEPS IN WALL 0.1m BEFORE BEGINNING OF WALL AND STEPS IN WALL 0.1m BEYOND END OF WALL AND STEPS IN WALL

EXAMPLE SHOWN

- 1) STA 100+03.90 (0.1m BEFORE BEGIN WALL)
- 2) STA 100+04.00 (BEGINNING OF WALL)
- 3) STA 100+04.65 (0.1m BEFORE STEP)
- 4) STA 100+04.75 (STEP IN WALL)
- 5) STA 100+08.40 (0.1m BEFORE STEP)
- 6) STA 100+08.50 (STEP IN WALL)
- 7) STA 100+09.15 (0.1m BEFORE STEP)
- 8) STA 100+09.25 (STEP IN WALL)
- 9) STA 100+09.90 (0.1m BEFORE STEP)
- 10) STA 100+10.00 (STEP IN WALL)
- 11) STA 100+15.00 (5m INCREMENT)
- 12) STA 100+16.00 (END OF LOWER TIER)
- 13) STA 100+16.10 (0.1m BEYOND LOWER TIER)
- 14) STA 100+19.75 (STEP IN WALL)
- 15) STA 100+19.85 (0.1m BEYOND STEP)
- 16) STA 100+22.00 (STEP IN WALL)
- 17) STA 100+22.10 (0.1m BEYOND STEP)
- 18) STA 100+22.75 (STEP IN WALL)
- 19) STA 100+22.85 (0.1m BEYOND STEP)
- 20) STA 100+23.50 (END OF WALL)
- 20) STA 100+23.60 (0.1m BEYOND WALL)

MoT Section	1270		TAC Section	Not Applicable
-------------	------	--	-------------	----------------

Detailed Design Cont.

- All intersection stations – access/intersection curves, etc.

The designer must supply vertical cutoff stations through an intersection, where major, minor, sideline and access/intersection curve horizontal alignment stations are coincident. These stations will include all key locations necessary for layout and to provide an accurate representation of earthwork quantities through an intersection. Key stations will include beginning and end of access/intersection curves, paint line convergences and island corners.

The following drawings show the typical requirements for spot elevations and design cross section stations required for construction supervision layout and earthwork calculations through an intersection. Cross section stations are to be supplied at the beginning and end of an intersection (Sta. 106+85.624 & 107+85.717) with full roadway width and a station 1cm outside of each of these stations at the vertical cutoff offset.

MoT Section	1270	TAC Section	Not Applicable
-------------	------	-------------	----------------

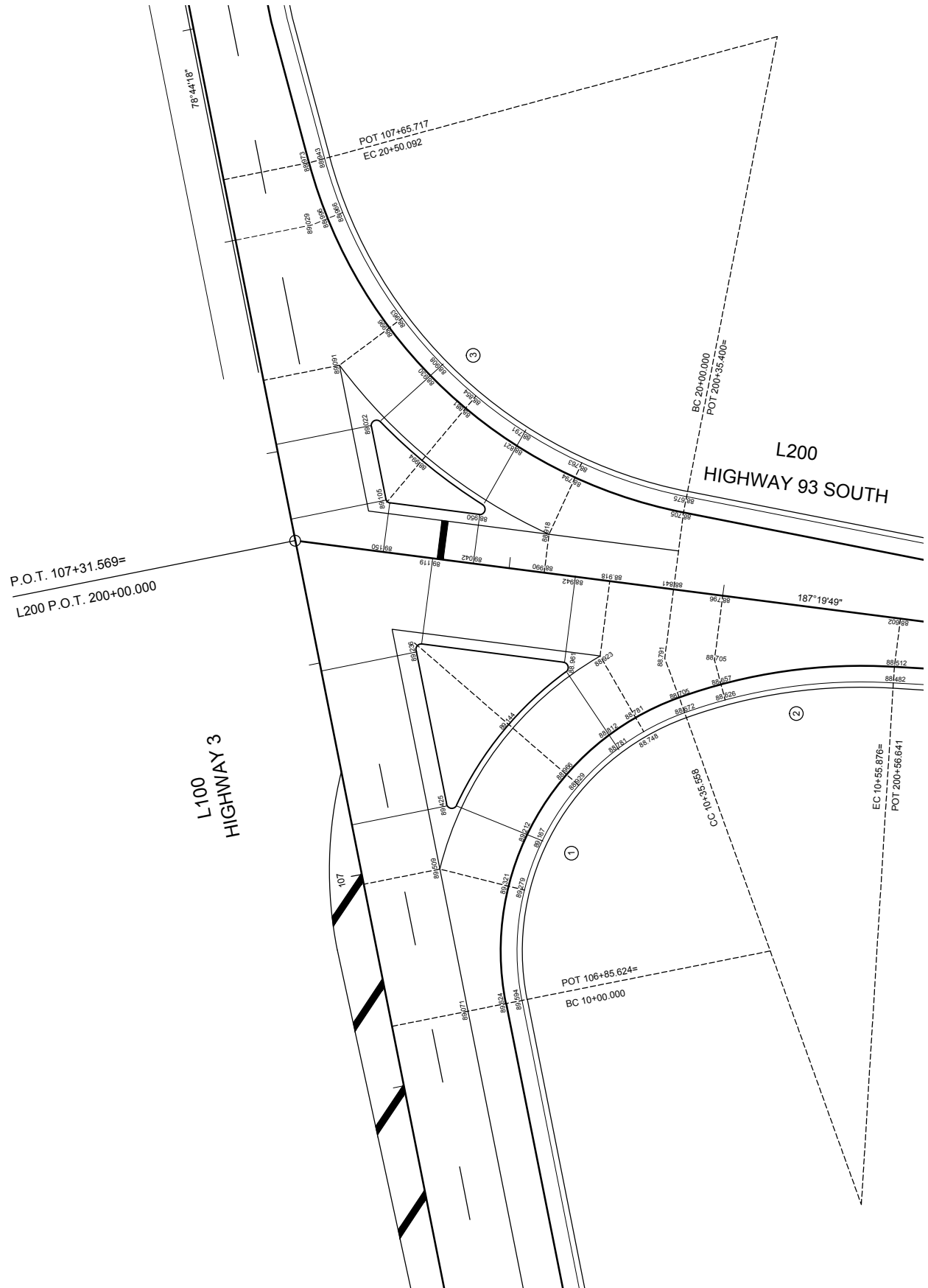

MoT Section	1270	TAC Section	Not Applicable
-------------	------	-------------	----------------

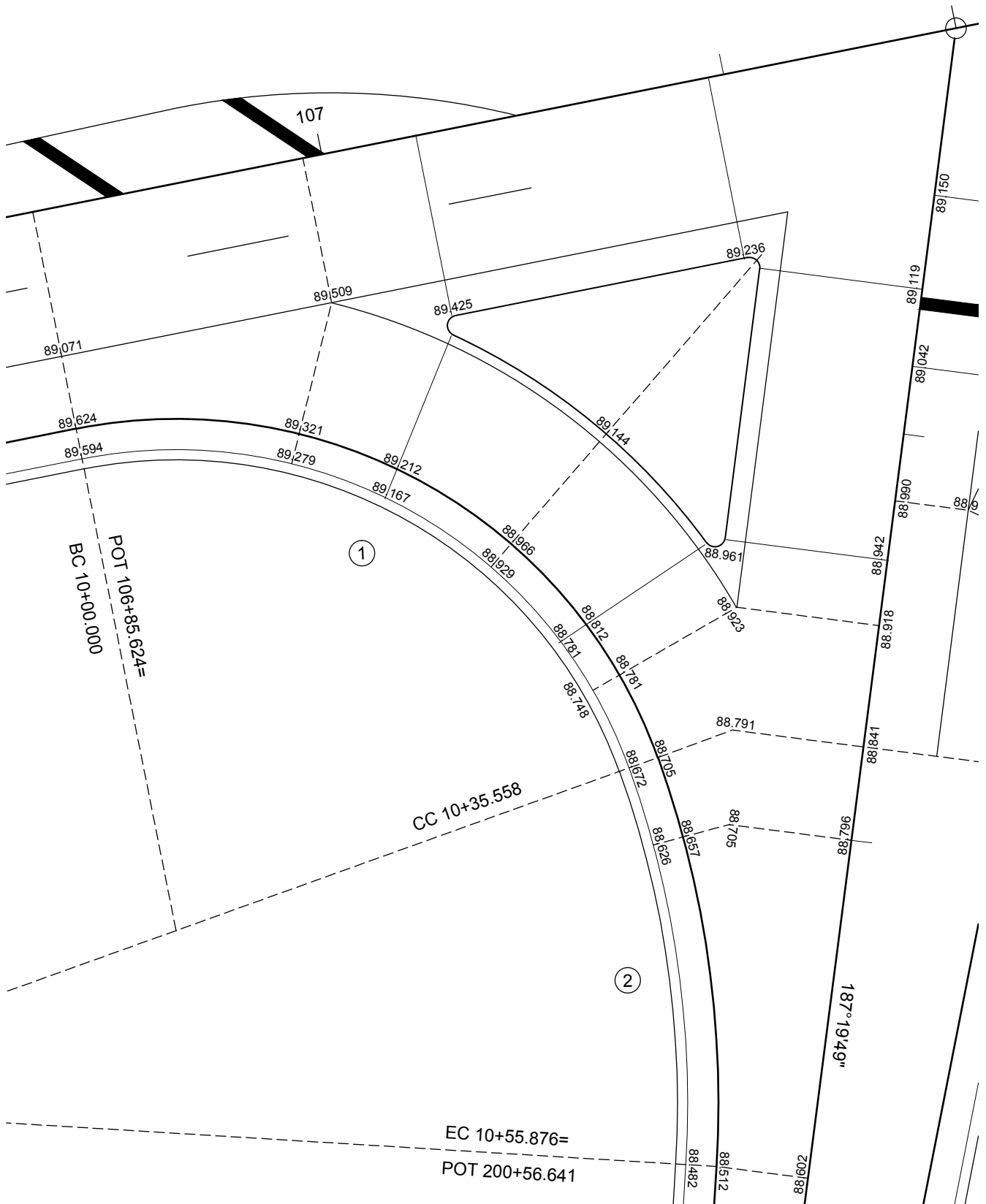

MoT Section	1270	TAC Section	Not Applicable
-------------	------	-------------	----------------

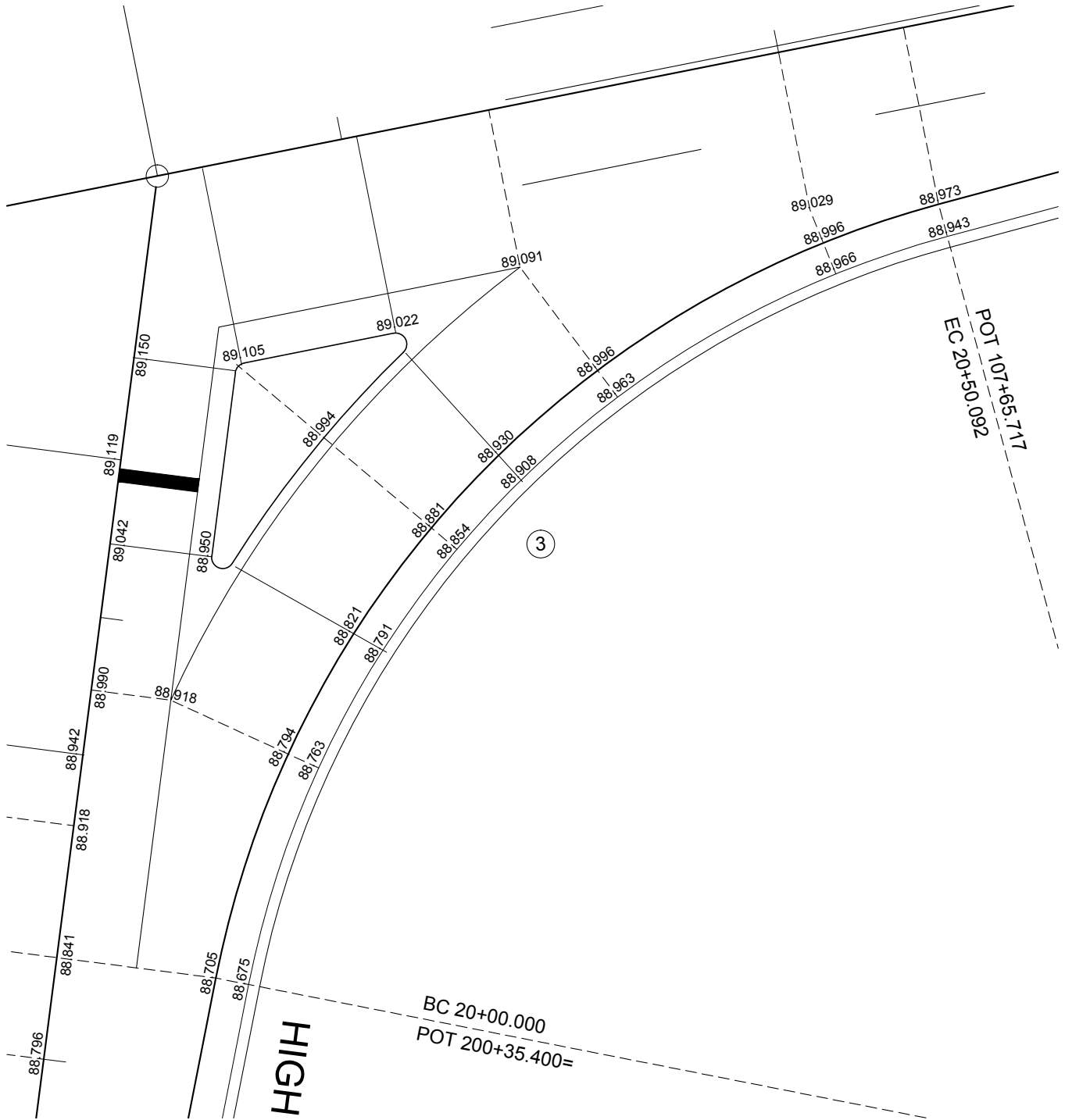

MoT Section	1270	TAC Section	Not Applicable
-------------	------	-------------	----------------

Cross Section Stations Text Files Cont.

Detailed Design Cont.

- All abrupt stations for cutoffs. Examples of abrupt stationing for cutoffs are reflected on the previous drawings detailing access/intersection curve requirements. Earthwork quantities will start and end abruptly at each end of the access/intersection curve as they are vertically tied to the 2 main alignments. There is no running in or out of the quantities (CAICE exceptions) as this is only a construction supervision remeasure concern.

The file naming convention that must be used for the designer created text files containing cross section station lists, is to prefix the file name with the name of the associated horizontal alignment and "STATIONS". For example the filename to be used for the L100A1 horizontal alignment stations list would be as follows:

L100A1 STATIONS.LIS

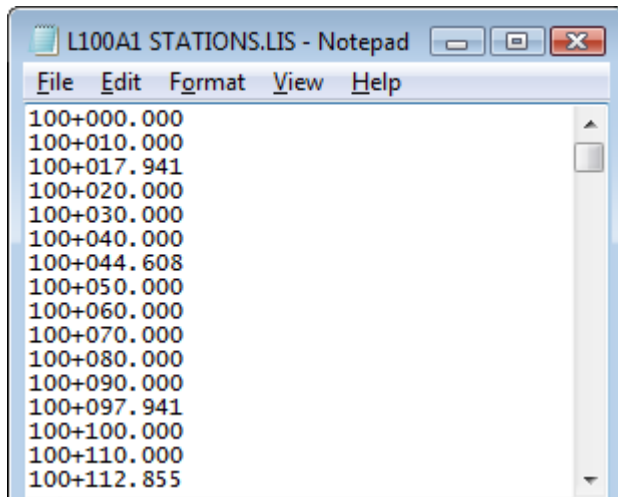

DTM Naming

Archive Requirement

- Preliminary Design – Yes
- Functional Design – Yes
- Detailed Design – Yes
- Construction – Yes

The basic design DTM surface naming conventions that must be used are to prefix all location survey and design created DTMs with an "S" for survey and a "D" for design. The remaining part of the DTM name must be limited to a maximum of 6 Characters.

Guidelines for naming DTMs and assigning corresponding feature codes are shown in the examples below:

Name "SOG"	Feature "OG"	Survey Original Ground
Name "DTYPEA"	Feature "TYPE-A"	Design TYPE-A Sub-surface
Name "DTYPEA1"	Feature "TYPE-A1"	Design TYPE-A1 Sub-surface
Name "DTYPEB"	Feature "TYPE-B"	Design TYPE-B Sub-surface
Name "DTYPEC3"	Feature "TYPE-C3"	Design TYPE-C3 Sub-surface

MoT Section	1270	TAC Section	Not Applicable
-------------	------	-------------	----------------

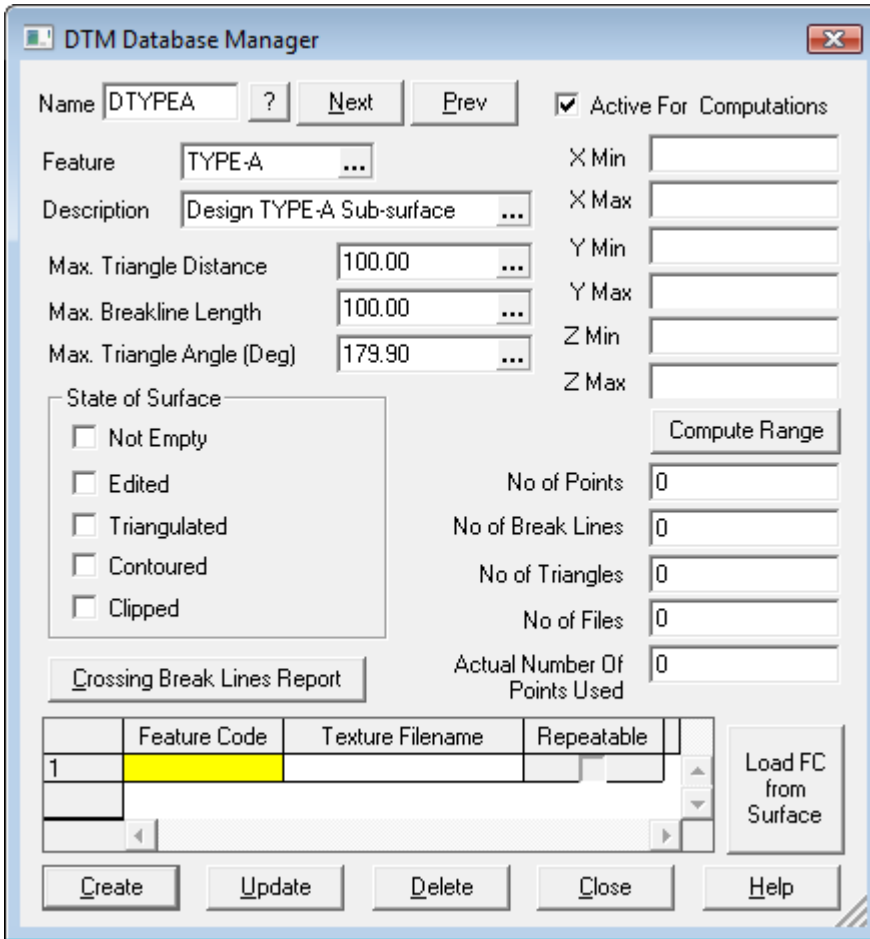

Data Source and Extent Boundary Definition

Archive Requirement

- Preliminary Design – Yes
- Functional Design – Yes
- Detailed Design – Yes
- Construction – Yes

Survey points and chains data source, extent boundary survey chains, are only to be generated by the designer if additional data is being added to the base original ground for design purposes. These survey chains must be generated in CAiCE using points from the survey database vs. digitized points.

These survey chains will provide anyone reviewing the project, a clear indication of what aspects of the base original ground have been collected from each data source, such as ground surveys, digital mapping, 3D laser scanning, LiDAR, etc. The basic naming convention that must be used is to prefix the survey chain name with “SURVEY”, “MAPPING”, “3DLASER, LiDAR” etc. The designer must assign the survey chain a feature code of BD. The designer should make full use of the description field if there is additional information needed to describe the element beyond what is required by the element naming convention.

This type of survey chain may already exist in the CAiCE survey data base, generated during the original location survey phase of the project.

SURVEY23, MAPPING19, 3DLASER303, LIDAR72

MoT Section	1270	TAC Section	Not Applicable
-------------	------	-------------	----------------

Terrain Profile PF\$ Files

Archive Requirement

- Preliminary Design – Yes
- Functional Design – Yes
- Detailed Design – Yes
- Construction – Yes

The basic CAiCE terrain profile file naming convention that must be used is to make the file name the same as the horizontal alignment name with an indication of what DTM was used. For example, the terrain profile file name to be used for a profile generated using the L100A1 horizontal alignment and the SOG DTM would be as follows:

L100A1-SOG

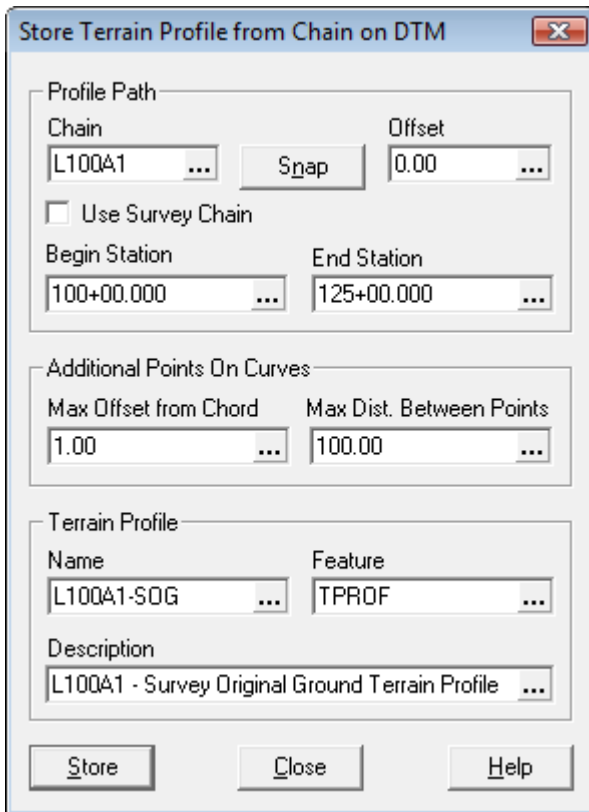

MoT Section	1270		TAC Section	Not Applicable
-------------	------	--	-------------	----------------

Base Cross Section EAR Files

Archive Requirement

- Preliminary Design – No
- Functional Design – Yes
- Detailed Design – Yes
- Construction – Yes

Base cross section EAR files must include all relevant geotechnical sub-surfaces used to complete the final design. In areas where there are clearly overhangs, the designer must make sure the necessary work is completed to introduce the overhangs into the base cross section files for design and construction supervision purposes. An example of overhang definition is shown in the Ministry General Survey Guide Section 900 CAiCE Survey Project Data Format Terms of Reference.

Design base cross section EAR files must contain cross sections for design and construction supervision purposes as detailed earlier in this section for the creation of cross section stations text files.

Below is the basic naming convention that must be used when creating a base cross section EAR file. The EAR file name is to be prefixed with the horizontal alignment name and then followed by the word “Base” and an optional description if there is additional information needed to describe a file’s contents. Example base EAR file names and descriptions are shown below:

L100A1 Base Stripping and Stripping Limits.EAR

L100A1 Base Milling.EAR

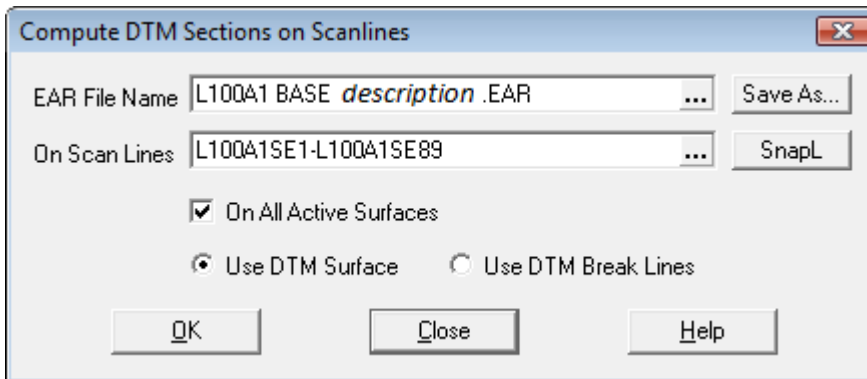

MoT Section	1270	TAC Section	Not Applicable
-------------	------	-------------	----------------

Design Profiles

Archive Requirement

- Preliminary Design – Yes
- Functional Design – Yes
- Detailed Design – Yes
- Construction – Yes

The basic CAiCE design profile element naming convention that must be used is to prefix the name with the horizontal alignment name as described earlier in this section and append the prefix with the design profile alternative indicator as shown below:

L100A1P1, L200A1P4, L300A1P5 etc.

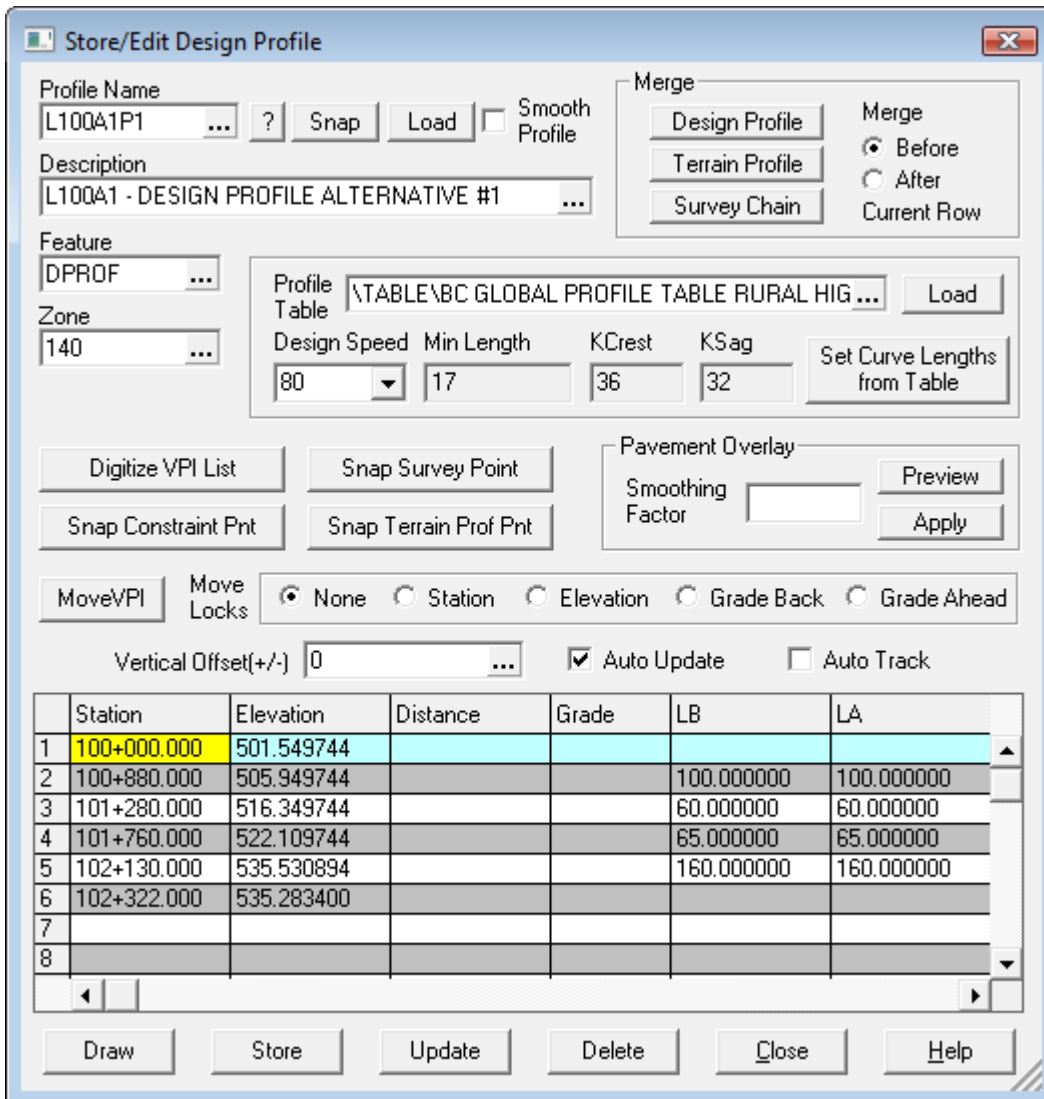

MoT Section	1270		TAC Section	Not Applicable
-------------	------	--	-------------	----------------

Design Cross Section EAR Files

Archive Requirement

- Preliminary Design – No
- Functional Design – Yes
- Detailed Design – Yes
- Construction – Yes

Final design cross section EAR files must contain cross sections at all stations required for construction supervision as detailed earlier in this section for the creation of cross section stations text files. Final design cross section EAR files must include those stations that are hard copied for project tender reference documents.

The designer must provide the complete detail for structures such as bridge abutments and walls etc. using the Ministry generic link fragments or specialized Ministry structure fragments when available, if structure construction is to be paid for by cubic metre. The included structures must be provided in sufficient detail that will allow construction supervision staff to calculate the different material volumes associated with the different structure configurations. The first set of wall structure drawings that follow, provide an indication of the structure related cross section surfaces to be created by the designer, their associated design surface names, and associated materials.

If structure construction is to be paid for by facial area or by an all inclusive cost, then only limited wall design detail is required to approximate wall structure excavation and backfill quantity calculations used for project tender reference purposes. The second set of wall structure drawings that follow, provide an indication of the structure excavation and backfill related cross section surfaces to be created by the designer, their associated design surface names, and associated materials.

If specific project typical section requirements cannot be accommodated by the Ministry standard fragments sets, then the Ministry generic link fragments must be used to complete the design. **No manual cross section editing is permitted in the completion of a CAICE design cross section EAR file.**

Below is the basic naming convention that must be used when creating a design cross section EAR file. The EAR file name is to be prefixed with the combined horizontal alignment and profile name. This is followed by an optional description if there is additional information needed to describe the file’s contents.

L100A1P1 description.EAR – Design Cross Section EAR File

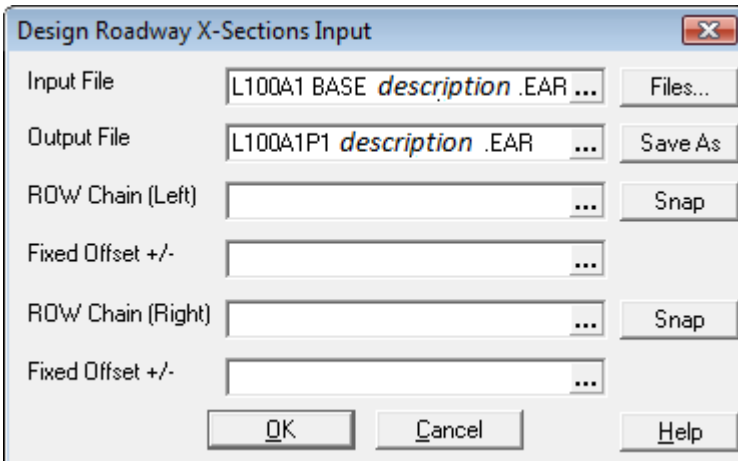

Input Name: L100A1 BASE description.EAR

Output Name: L100A1P1 description.EAR

MoT Section	1270	TAC Section	Not Applicable
-------------	------	-------------	----------------

**Breast Wall
Excavation Surfaces and Materials**

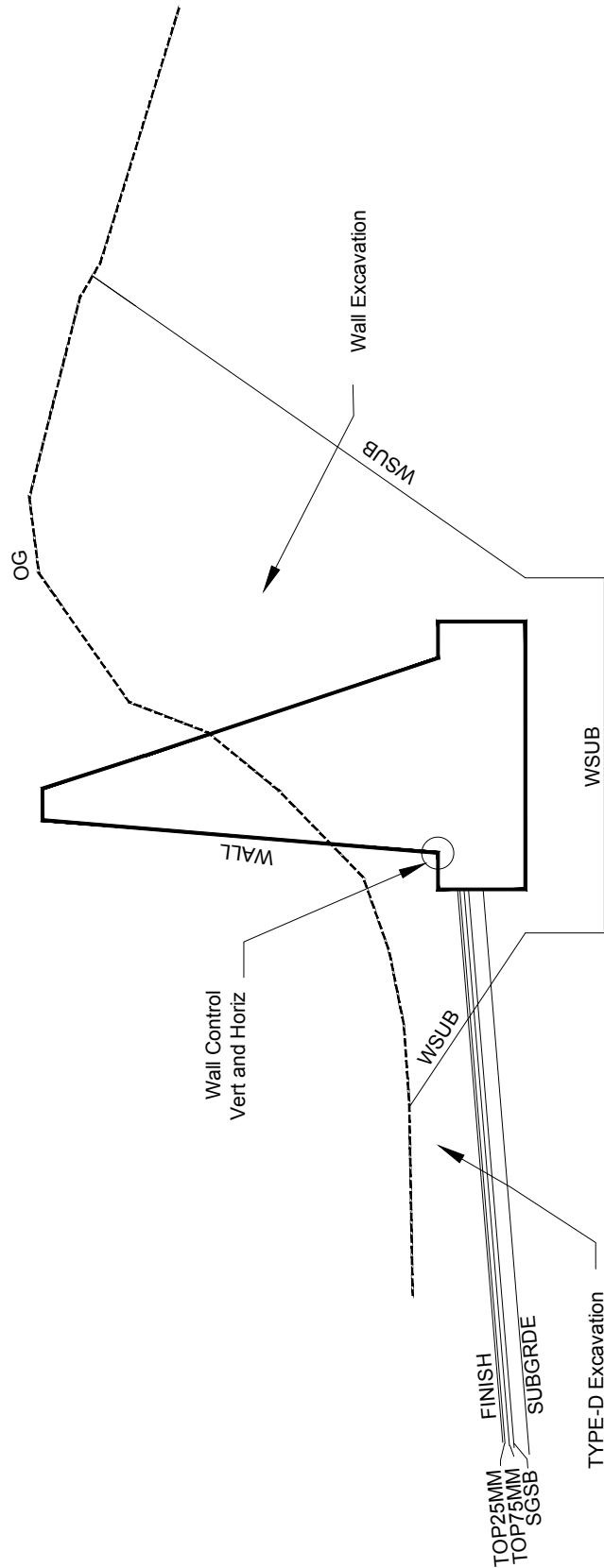

**Breast Wall
Excavation Surfaces and Materials**

**Breast Wall
Fill Surfaces and Materials**

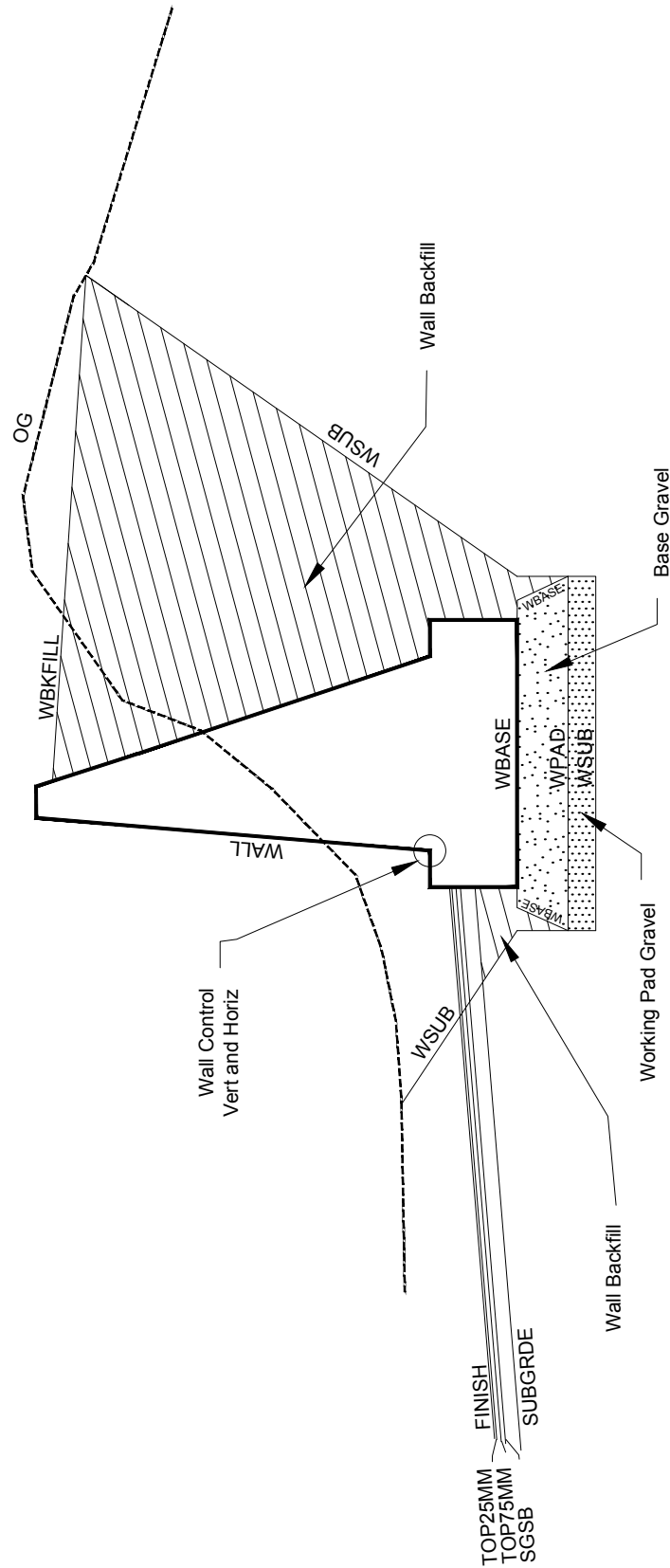

**Breast Wall
Fill Surfaces and Materials**

MoT Section	1270	TAC Section	Not Applicable
-------------	------	-------------	----------------

**Gravity Wall (Cut Scenario)
Excavation Surfaces and Materials**

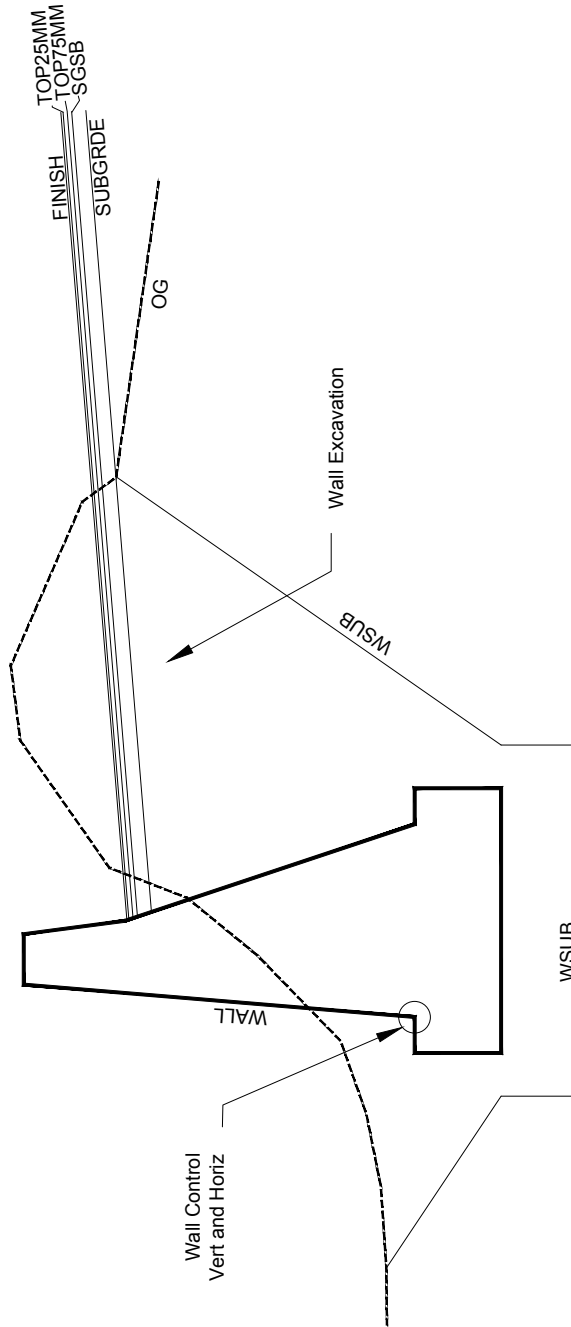

**Gravity Wall (Cut Scenario)
Excavation Surfaces and Materials**

MoT Section	1270	TAC Section	Not Applicable
-------------	------	-------------	----------------

**Gravity Wall (Cut Scenario)
Fill Surfaces and Materials**

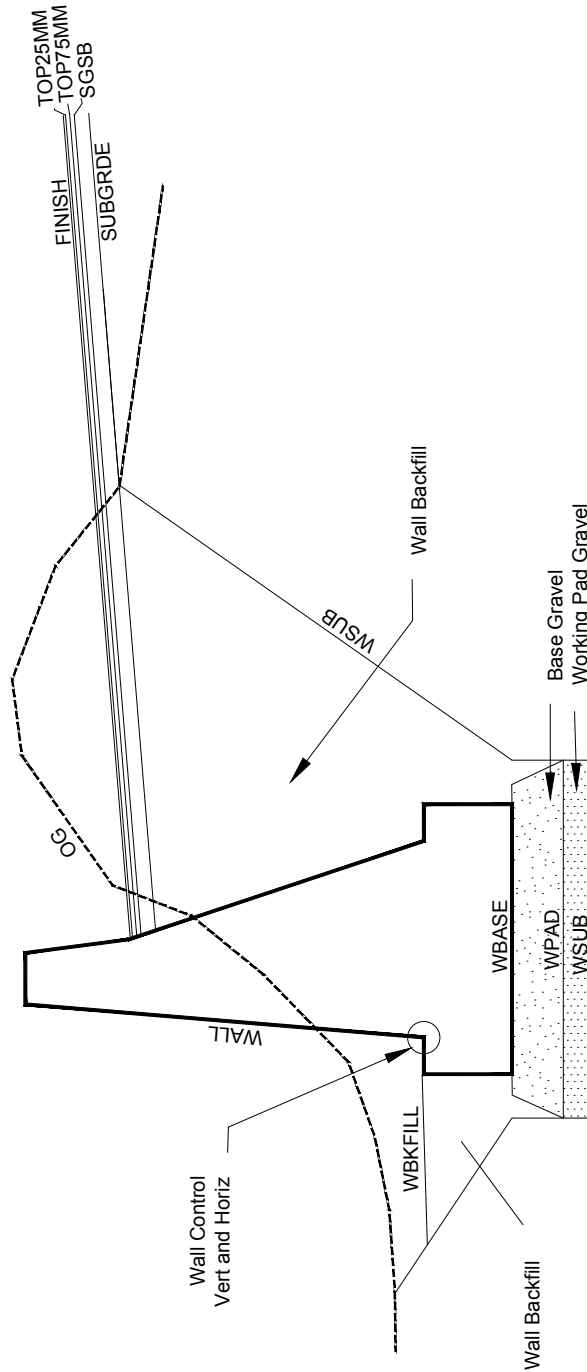

**Gravity Wall (Cut Scenario)
Fill Surfaces and Materials**

MoT Section	1270	TAC Section	Not Applicable
-------------	------	-------------	----------------

**Gravity Wall (Fill Scenario)
Excavation Surfaces and Materials**

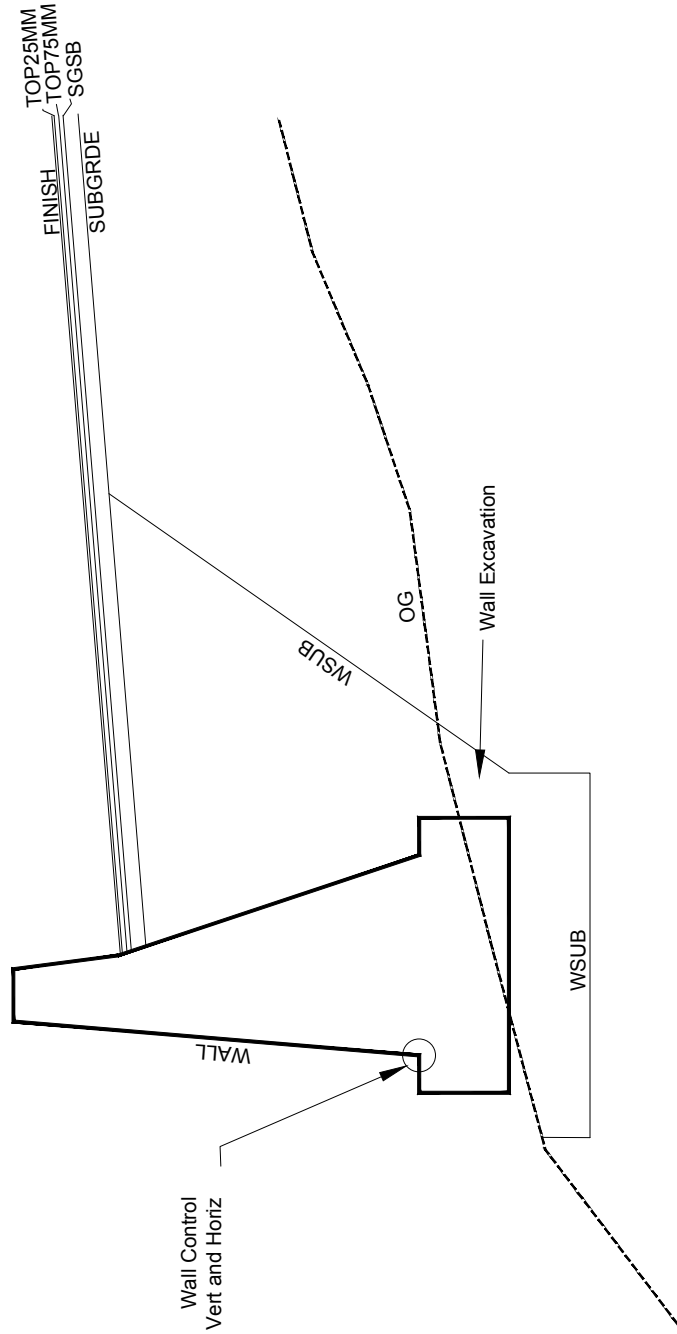

**Gravity Wall (Fill Scenario)
Excavation Surfaces and Materials**

MoT Section	1270	TAC Section	Not Applicable
-------------	------	-------------	----------------

**Gravity Wall (Fill Scenario)
Fill Surfaces and Materials**

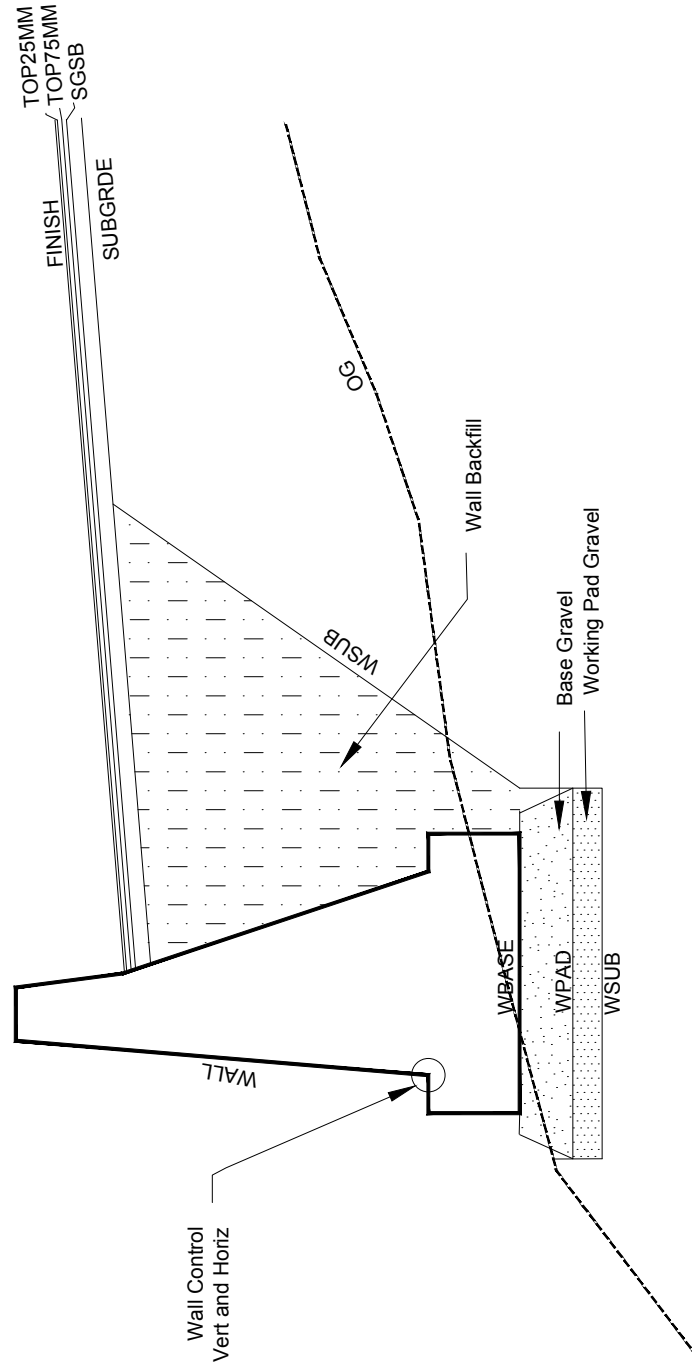

**Gravity Wall (Fill Scenario)
Fill Surfaces and Materials**

MoT Section	1270	TAC Section	Not Applicable
-------------	------	-------------	----------------

**Modular Concrete Wall (Flat Pad)
Excavation Surfaces and Materials**

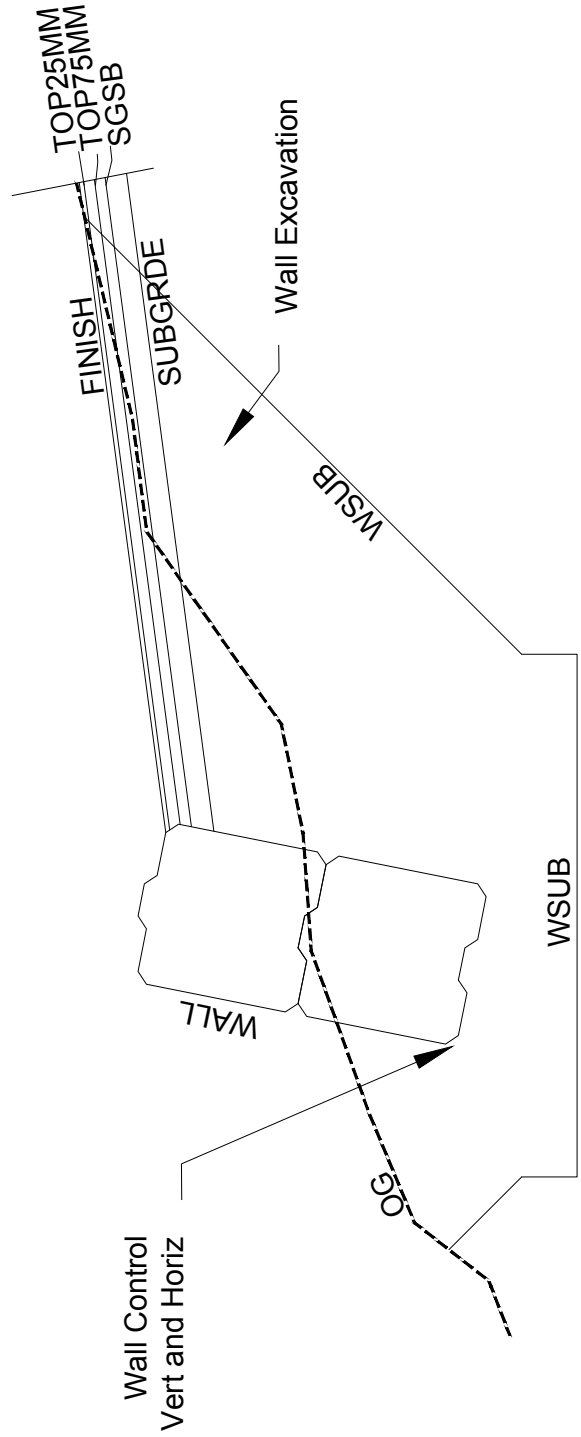

**Modular Concrete Wall (Flat Pad)
Excavation Surfaces and Materials**

MoT Section	1270	TAC Section	Not Applicable
-------------	------	-------------	----------------

**Modular Concrete Wall (Flat Pad)
Fill Surfaces and Materials**

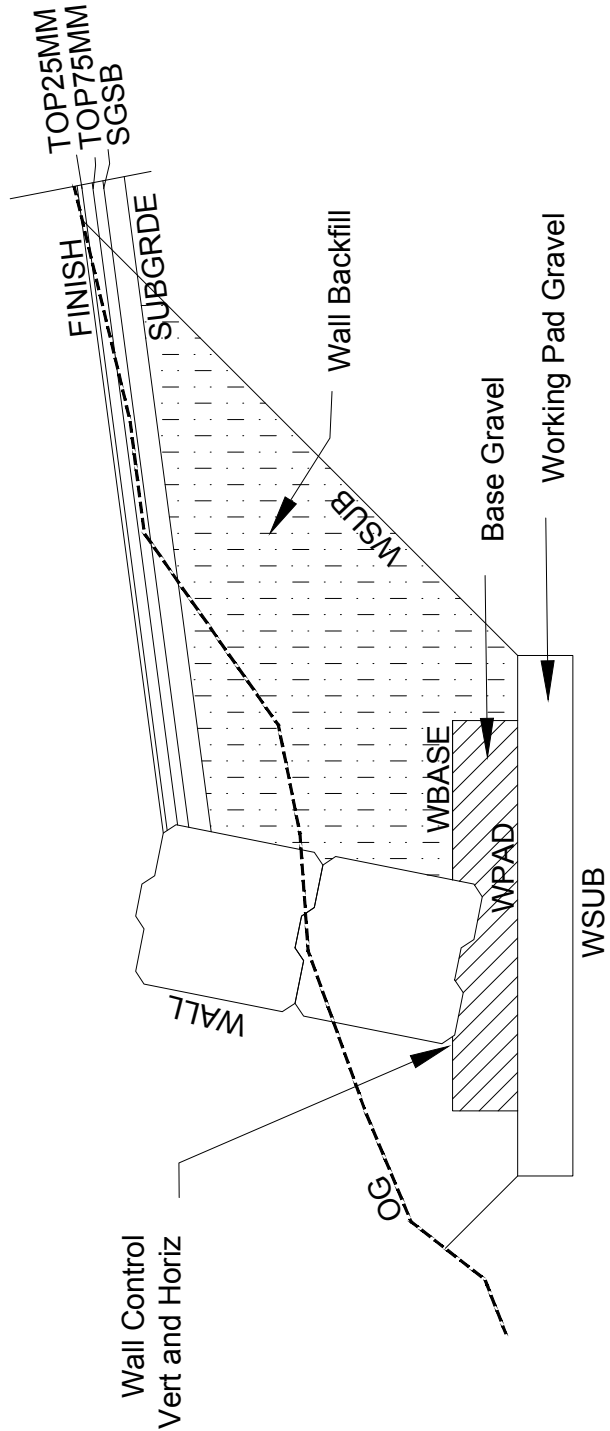

**Modular Concrete Wall (Flat Pad)
Fill Surfaces and Materials**

MoT Section	1270	TAC Section	Not Applicable
-------------	------	-------------	----------------

**Modular Concrete Wall (Sloped Pad)
Fill Surfaces and Materials**

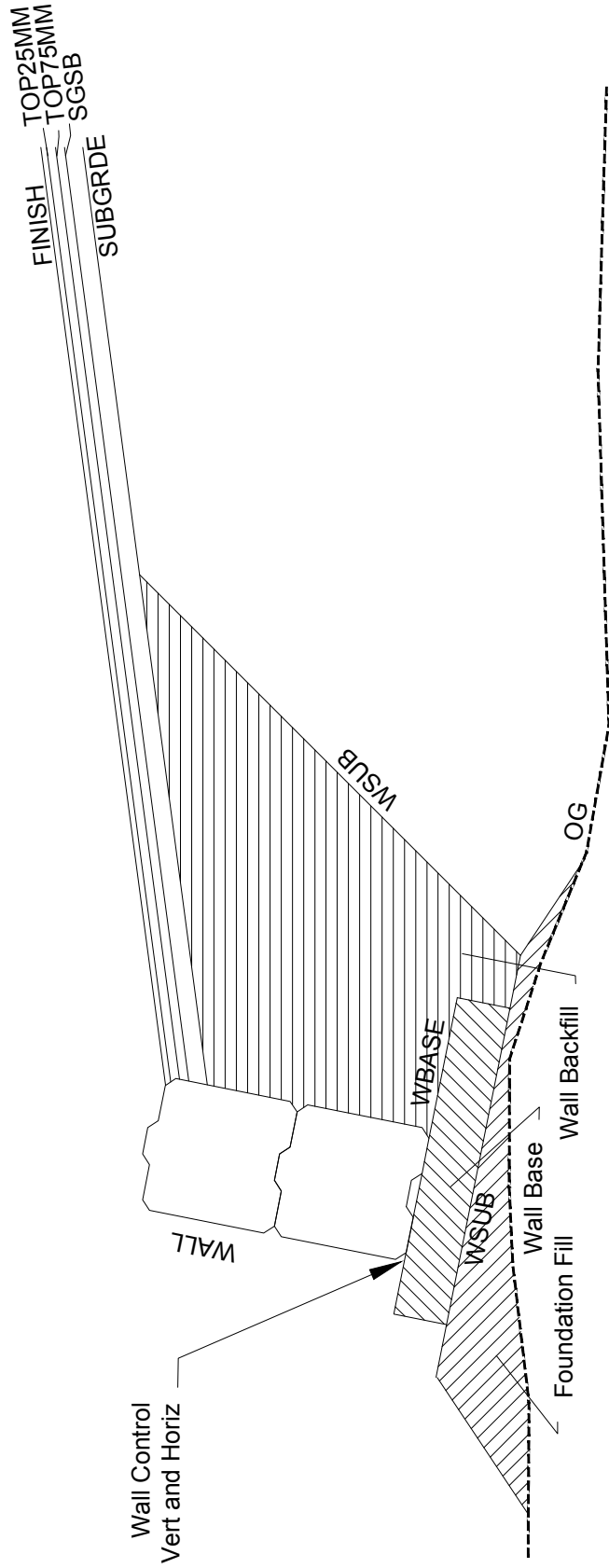

**Modular Concrete Wall (Sloped Pad)
Fill Surfaces and Materials**

MoT Section	1270	TAC Section	Not Applicable
-------------	------	-------------	----------------

Reinforced Earth Wall
Excavation Surfaces and Materials

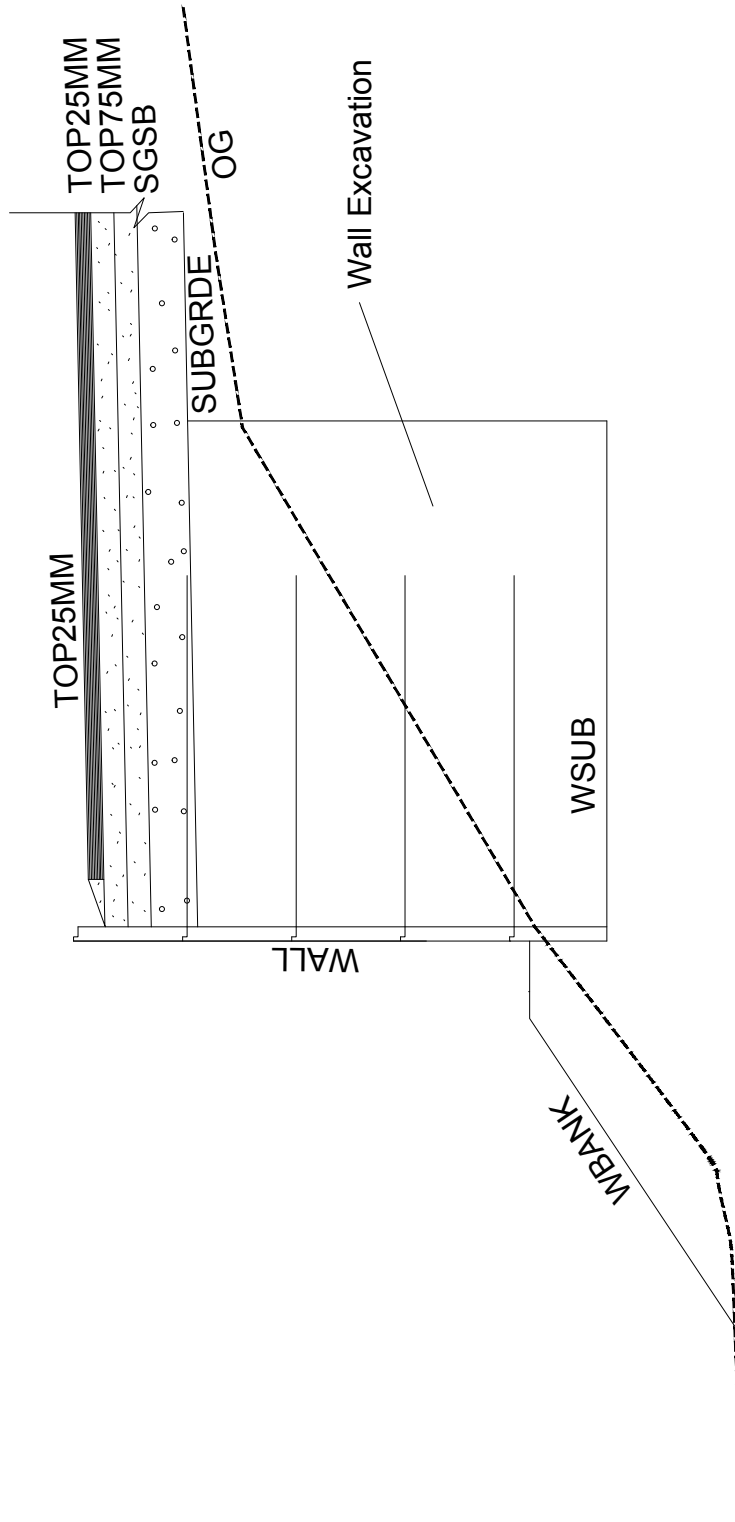

Reinforced Earth Wall
Excavation Surfaces and Materials

MoT Section	1270	TAC Section	Not Applicable
-------------	------	-------------	----------------

Reinforced Earth Wall
Fill Surfaces and Materials

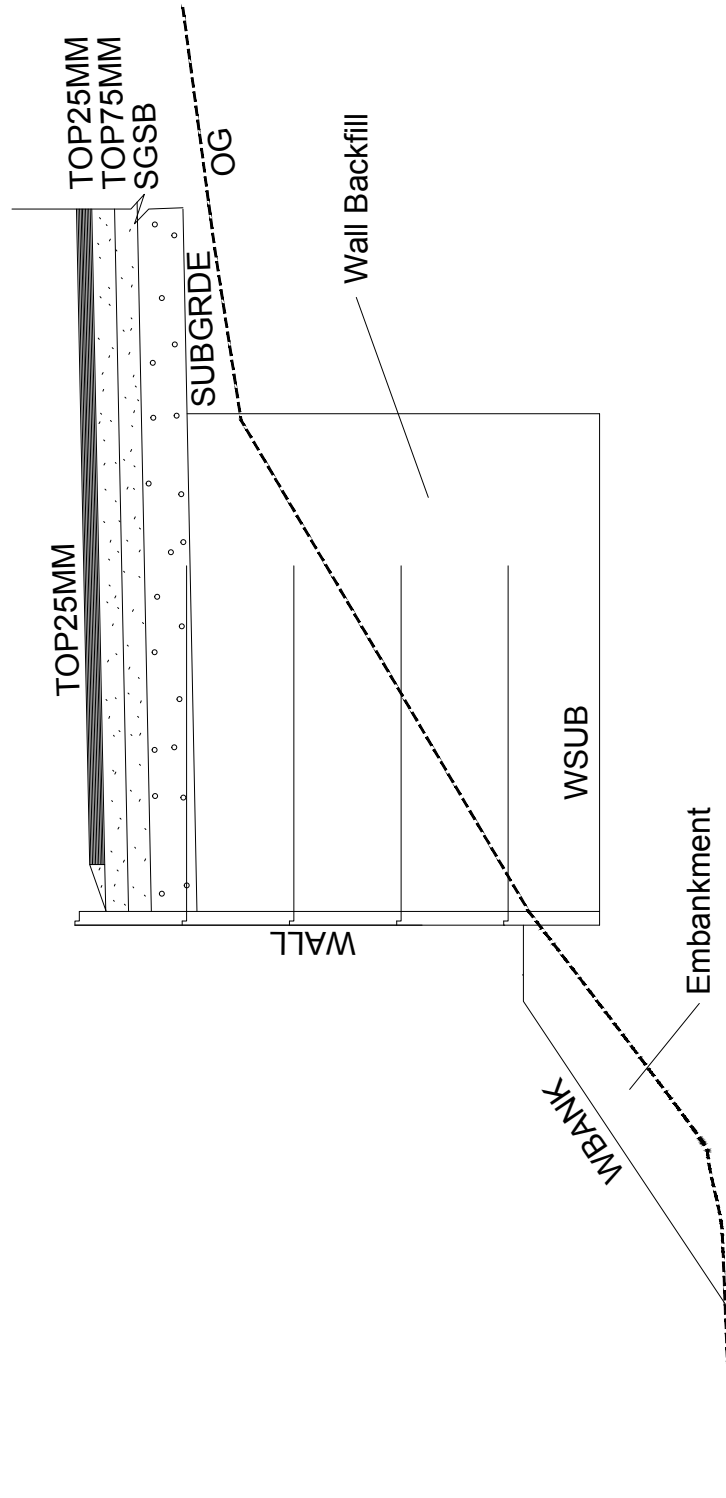

Reinforced Earth Wall
Fill Surfaces and Materials

MoT Section	1270	TAC Section	Not Applicable
-------------	------	-------------	----------------

Breast Wall
Excavation, Backfill and Gravels Included in Wall Price

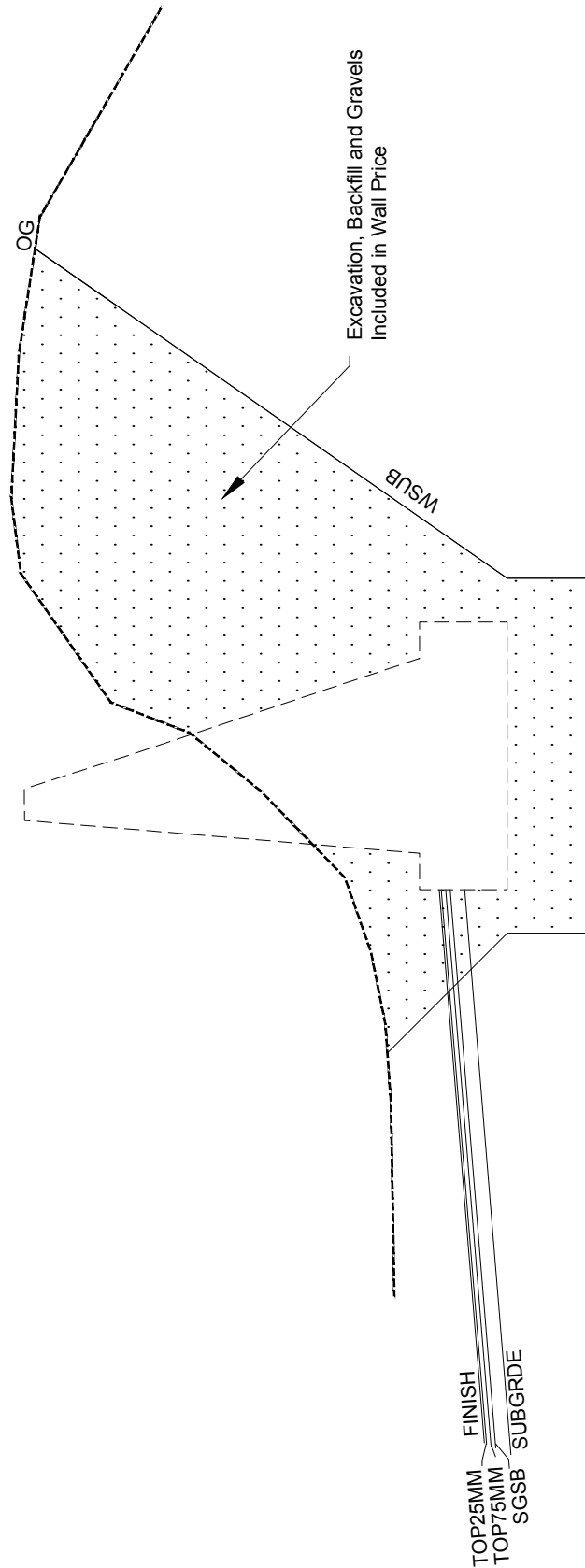

Breast Wall
Excavation, Backfill and Gravels Included in Wall Price

MoT Section	1270	TAC Section	Not Applicable
-------------	------	-------------	----------------

Gravity Wall (Cut Scenario)
Excavation, Backfill and Gravels Included in Wall Price

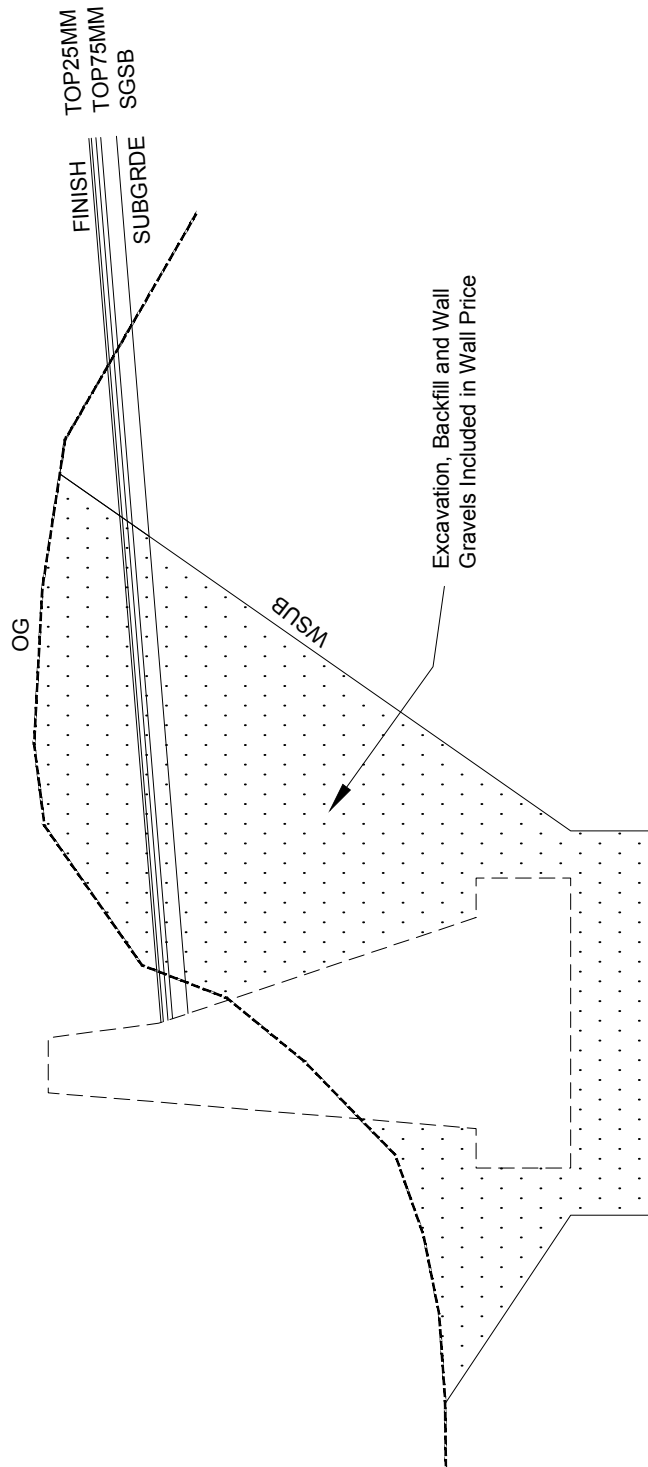

Gravity Wall (Cut Scenario)
Excavation, Backfill and Gravels Included in Wall Price

MoT Section	1270	TAC Section	Not Applicable
-------------	------	-------------	----------------

Gravity Wall (Fill Scenario)
Excavation, Backfill and Gravels Included in Wall Price

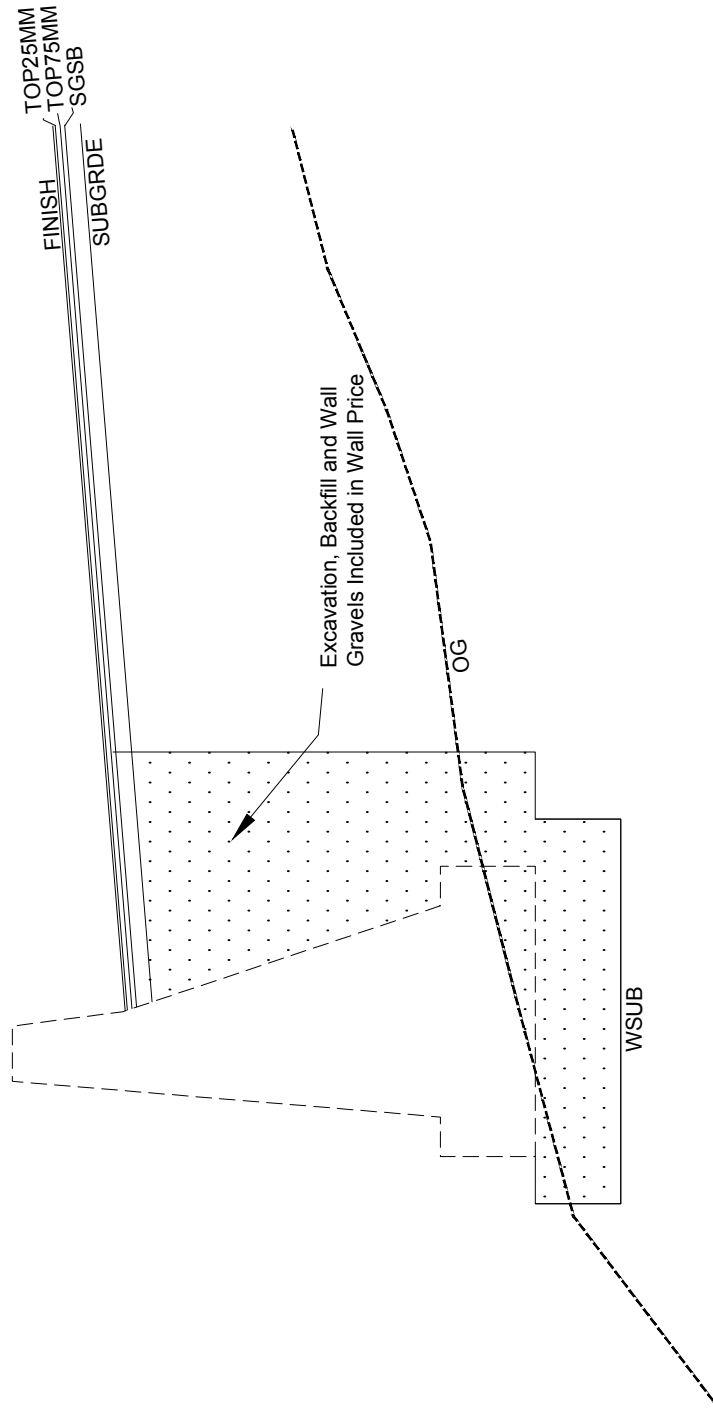

Gravity Wall (Fill Scenario)
Excavation, Backfill and Gravels Included in Wall Price

MoT Section	1270	TAC Section	Not Applicable
-------------	------	-------------	----------------

Modular Concrete Wall (Flat Pad)
Excavation, Backfill and Gravels Included in Wall Price

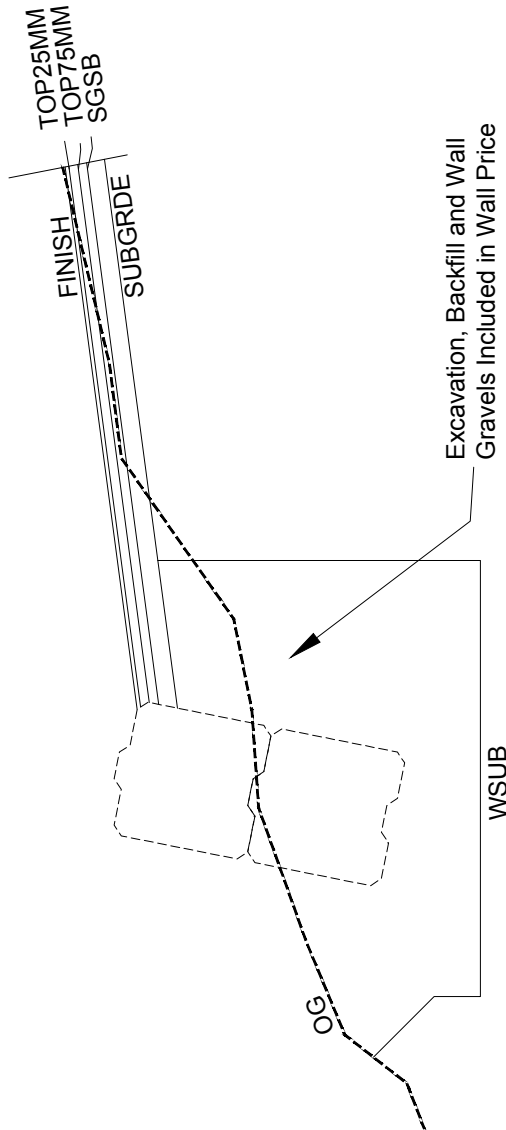

Modular Concrete Wall (Flat Pad)
Excavation, Backfill and Gravels Included in Wall Price

MoT Section	1270	TAC Section	Not Applicable
-------------	------	-------------	----------------

Modular Concrete Wall (Sloped Pad)
Excavation, Backfill and Gravels Included in Wall Price

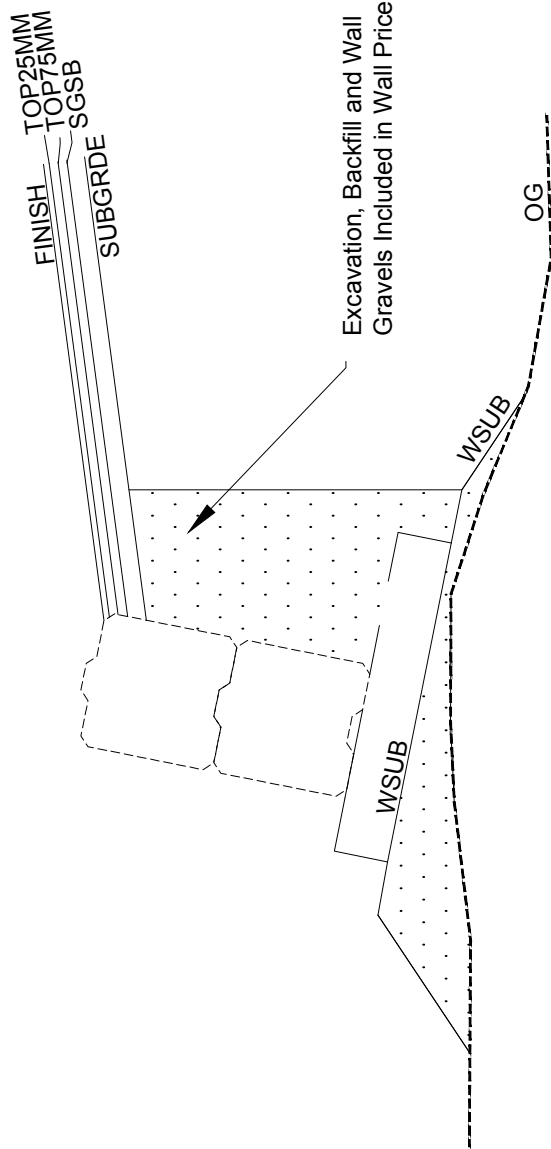

Modular Concrete Wall (Sloped Pad)
Excavation, Backfill and Gravels Included in Wall Price

MoT Section	1270		TAC Section	Not Applicable
-------------	------	--	-------------	----------------

Design Cross Section Surface Names

Archive Requirement

- Preliminary Design – No
- Functional Design – Yes
- Detailed Design – Yes
- Construction – Yes

The basic design cross section surface naming conventions that must be used are those that have been defined by the Ministry standard Rural, Urban, Pavement Overlay, Barrier, Miscellaneous and Labelling Annotation fragment input parameter defaults. Renaming of the design cross section surfaces by changing fragment input parameter defaults, should only be done if there is a legitimate requirement for the design situation to deviate from the Ministry standard conventions.

An example of this would be when there is no 75mm crushed base course gravel available and 50mm crushed base course gravel is being used in its place. In this example, the design cross section surface name that defaults to "TOP75MM" would be changed to something descriptive such as "TOP50MM".

If a designer must deviate from the standard defaults, then the design cross section surface names used must be descriptive, maximum of 7 characters and added as new line features into the project feature table.

Generic Link Design Cross Section Surface Names

Archive Requirement

- Preliminary Design – No
- Functional Design – Yes
- Detailed Design – Yes
- Construction – Yes

When a designer requires the use of the generic link fragments to define a complex design situation, the designer must rename the default design cross section surface name input parameter from "LINK" to something descriptive. This may be either a new surface name or a name that already exists as a line feature in the project feature table.

If new design cross section surface names are used, they must be descriptive, maximum of 7 characters and added as new line features into the project feature table.

MoT Section	1270	TAC Section	Not Applicable
-------------	------	-------------	----------------

Design Fragment Application Geometry Chains

Archive Requirement

- Preliminary Design – No
- Functional Design – Yes
- Detailed Design – Yes
- Construction – Yes

Ministry design fragments provide the capability to define specific typical section widths using longitudinal geometry chains. For widths, this functionality is used when there is a requirement to introduce roadway tapers. Examples of some of these geometry chains are as follows:

- Geometry chain to control depressed median widths
- Geometry chain to control lane width
- Geometry chain to control sidewalk width
- Geometry chain to control edge of pavement width for barrier flares

The basic design fragment application geometry chain naming convention that must be used is to prefix the geometry chain name with the alignment name, geometry chain type and left or right side. Geometry chain type would be the proposed roadway feature that is being generated such as PSH for proposed shoulder or PLE for proposed lane edge to identify the geometry chain. The designer should make full use of the description field if there is additional information needed to describe the element beyond what is required by the element naming convention.

100PSHR65, 100PLEL79, etc.

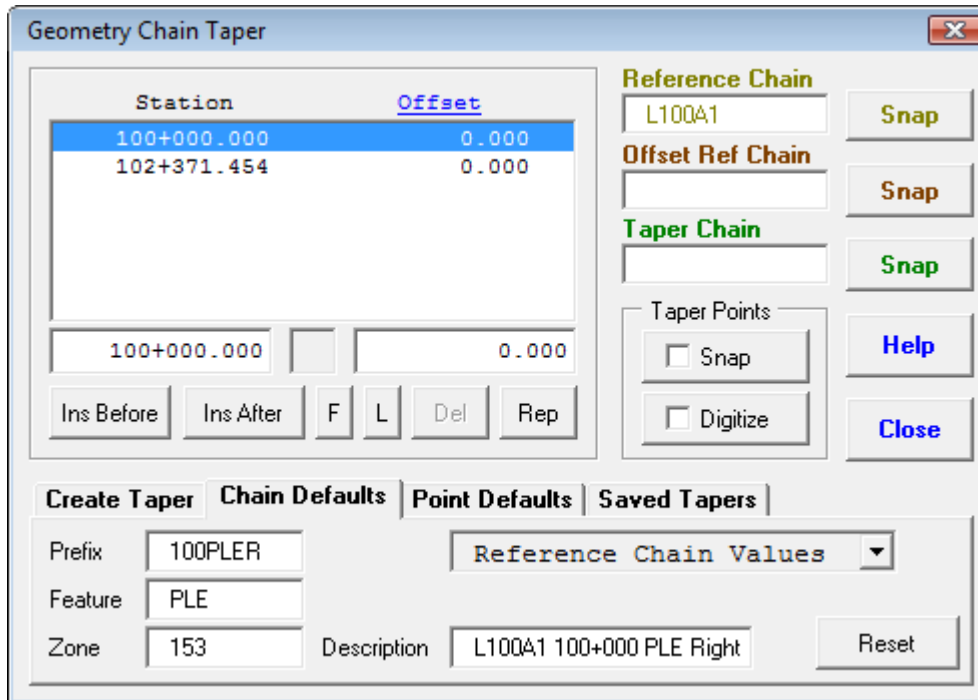

It is preferable that design fragment application geometry chains be generated in CAICE using the BCMoT Geometry Chain Taper macro, but geometry chains created in AutoCAD and then imported into CAICE are acceptable. The BCMoT Geometry Chain Taper macro will generate a more accurate spiral and curve representation.

MoT Section	1270	TAC Section	Not Applicable
-------------	------	-------------	----------------

Design Generated Points

Archive Requirement

- Preliminary Design – No
- Functional Design – Yes
- Detailed Design – Yes
- Construction – Yes

When creating design related points in the CAiCE survey database, the point name must be prefixed with the proposed point feature. The point feature must reflect the type of feature being defined such as proposed shoulder (PSH), proposed edge of pavement (PEP) and horizontal geometry point (HGPNT) etc. The example below shows the BCMoT Geometry Chain Taper macro generating points on a geometry chain created with a point name prefix of PSH, feature of PSH and a point description input as proposed gravel shoulder point.

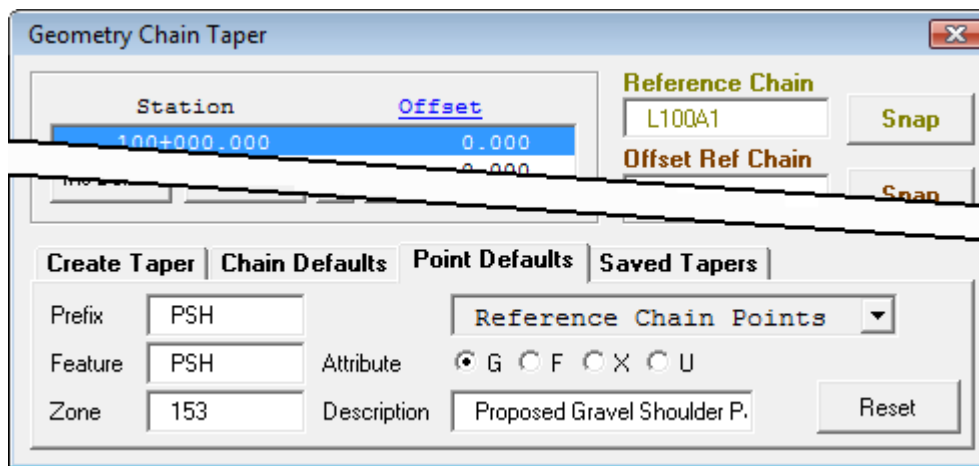

Design Fragment Marked Point Names

Archive Requirement

- Preliminary Design – No
- Functional Design – Yes
- Detailed Design – Yes
- Construction – Yes

Ministry design fragments provide the capability to mark specific typical section points. This capability is provided to assist the designer in using the generic link fragments to define typical section details that cannot be accommodated by the current Ministry suite of rural, urban and pavement overlay design fragments.

The designer is encouraged to use marked points, as it will significantly reduce the time spent working with generic links. The basic naming convention that must be used is to prefix all marked points with “Z” followed by a descriptive 6 character maximum name.

ZEPL (Edge of Pavement Left), ZDCR (Ditch Centre Right), etc.

MoT Section	1270	TAC Section	Not Applicable
-------------	------	-------------	----------------

Design Fragment Application Profiles

Archive Requirement

- Preliminary Design – Yes
- Functional Design – Yes
- Detailed Design – Yes
- Construction – Yes

Ministry design fragments provide the capability to define specific typical section elevations using a longitudinal profile. Examples of some of these profiles are as follows:

- Profile to control the depressed median centre depth elevations
- Profile to control the depth of ditches in cut
- Profile to control the elevation of berms in cut and fill

The basic design fragment application profile naming convention that must be used is to prefix the profile name with the alignment name, profile type and left or right side. Profile type would be the proposed roadway feature that is being generated such as PDC for proposed centre of ditch or PBE for proposed berm to identify the profile. The designer should make full use of the description field if there is additional information needed to describe the element beyond what is required by the element naming convention.

100PDCR75, 100PBEL88, etc.

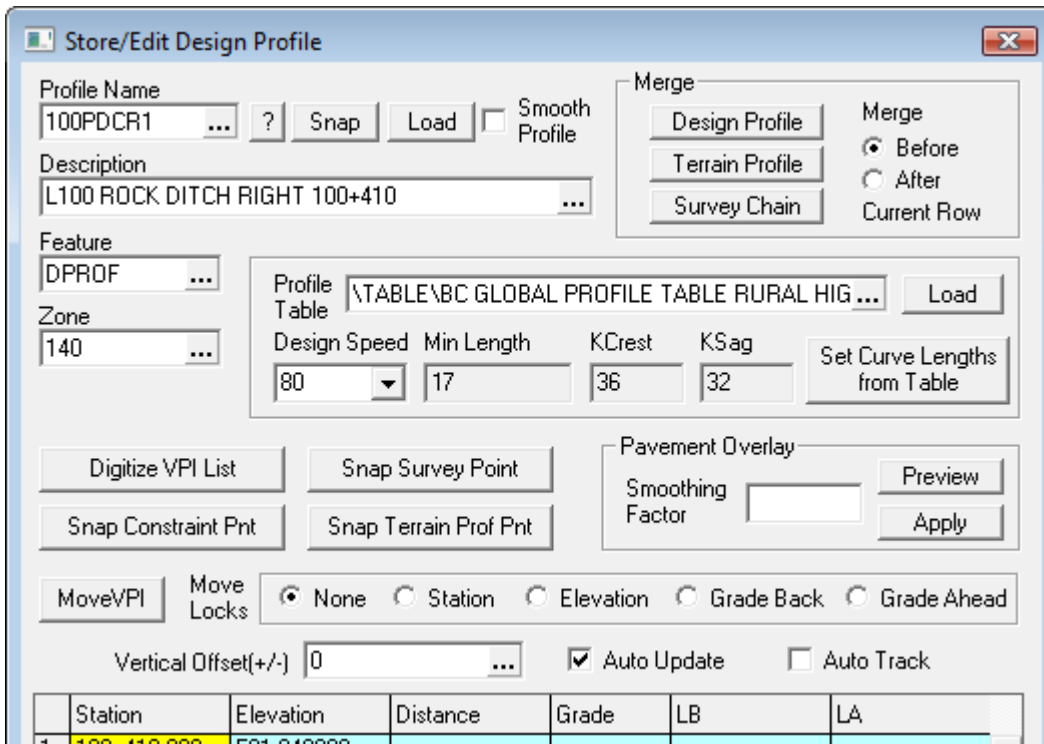

MoT Section	1270	TAC Section	Not Applicable
-------------	------	-------------	----------------

Design VRS Files

Archive Requirement

- Preliminary Design – No
- Functional Design – Yes
- Detailed Design – Yes
- Construction – Yes

The basic design VRS File naming convention that must be used is to prefix the name with the combined horizontal alignment and profile name followed by a descriptive name that describes the design.

L100A1P3 description.VRS

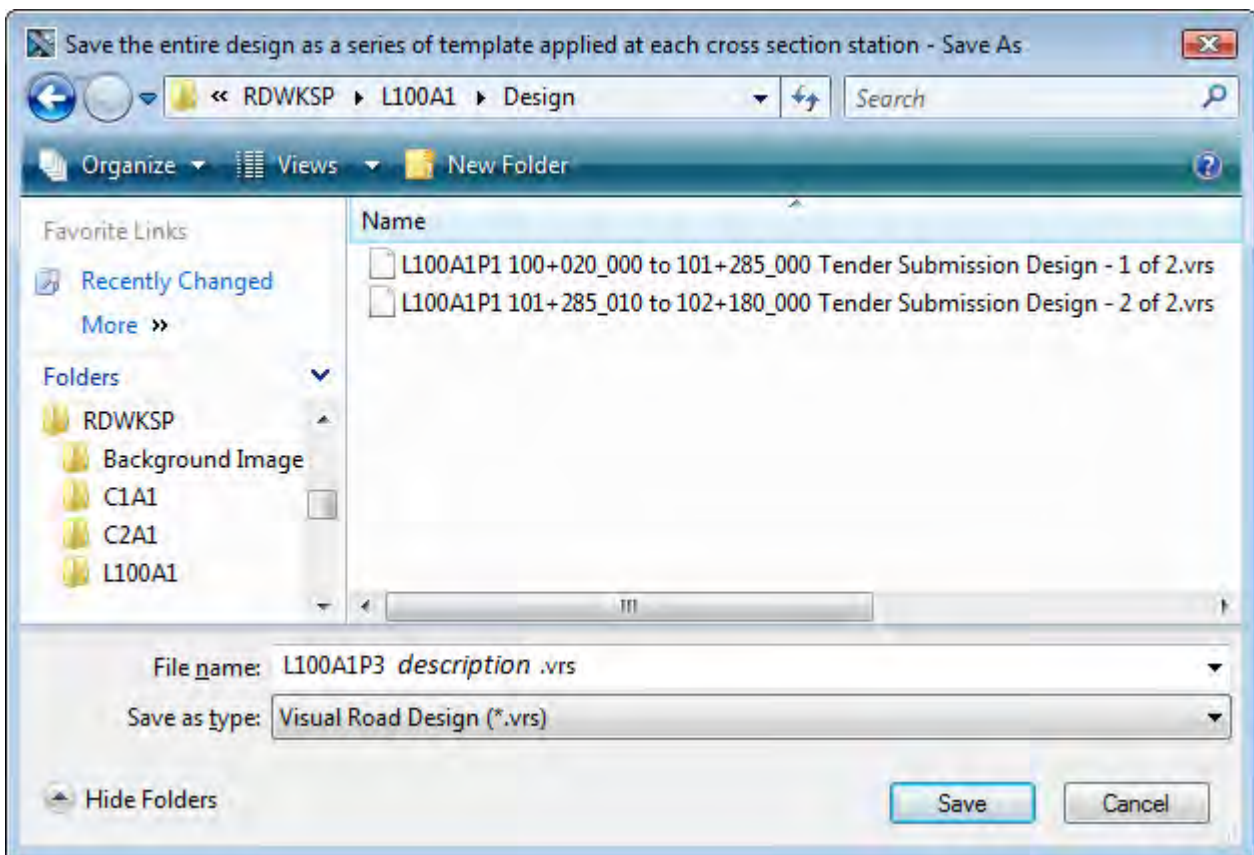

MoT Section	1270	TAC Section	Not Applicable
-------------	------	-------------	----------------

Design Earthwork Classification Table Files

Archive Requirement

- Preliminary Design – No
- Functional Design – Yes
- Detailed Design – Yes
- Construction – Yes

The basic design earthwork classification table file naming convention that must be used is to prefix the name with “EWCLASS”, the combined horizontal alignment, profile name, station range (if there are multiple tables for an alignment), material types and then followed by an optional description if there is additional information needed to describe the file’s contents.

EWCLASS L100A1P3 101+55 to 120+60 ASPHALT and GRAVELS Description.TBL

EWCLASS L100A1P3 101+55 to 120+60 EXCAVATION and EMBANKMENT Description.TBL

EWCLASS L100A1P3 101+55 to 120+60 STRIPPING Description.TBL

EWCLASS L100A1P3 101+55 to 120+60 STRUCTURES EXCAVATION Description.TBL

The only exception to this would be if an earthwork classification table is used for multiple horizontal alignments. If this is the case, then the table must be prefixed with “EWCLASS”, any horizontal alignments the table is associated with, the material types and then followed by an optional description if there is additional information needed to describe the file’s contents. For this situation, because the file is generic, it must be saved in the project miscellaneous folder.

EWCLASS L100A1P3 L100A1P4 ASPHALT and GRAVELS Description.TBL

EWCLASS L100A1P3 L100A1P4 EXCAVATION and EMBANKMENT Description.TBL

EWCLASS L100A1P3 L100A1P4 STRIPPING Description.TBL

EWCLASS L100A1P3 L100A1P4 STRUCTURES EMBANKMENT Description.TBL

MoT Section	1270	TAC Section	Not Applicable
-------------	------	-------------	----------------

Driveway Requirements

Archive Requirement

- Preliminary Design – No
- Functional Design – No
- Detailed Design – Yes
- Construction – Yes

In the past, typically there has been insufficient information supplied for construction supervision to indicate how and where a driveway would tie to the existing original ground. For the sake of driveway requirements of the CAiCE Design Project Data Format Policy: Terms of Reference, driveways will be broken down into three different types: simple, intermediate and advanced.

- Simple Driveway Design

When there is minimal grade difference between the new highway construction and the property requiring access and minimal material is required to tie to the existing original ground, then there will be no special CAiCE design deliverable driveway requirement.

- Intermediate Driveway Design

When there is a difference in grade between the new highway construction and the property requiring access and there is a requirement to move material to tie the driveway to the existing original ground, then there is a special CAiCE design deliverable driveway requirement.

If the difference in grade, length of driveway and driveway complexity do not warrant a driveway design utilizing similar criteria as a minor or sideline roadway, then a special 3D Driveway Chain (CAiCE Survey Chain) must be generated to provide sufficient tie-in information for construction supervision. Refer to the diagram below:

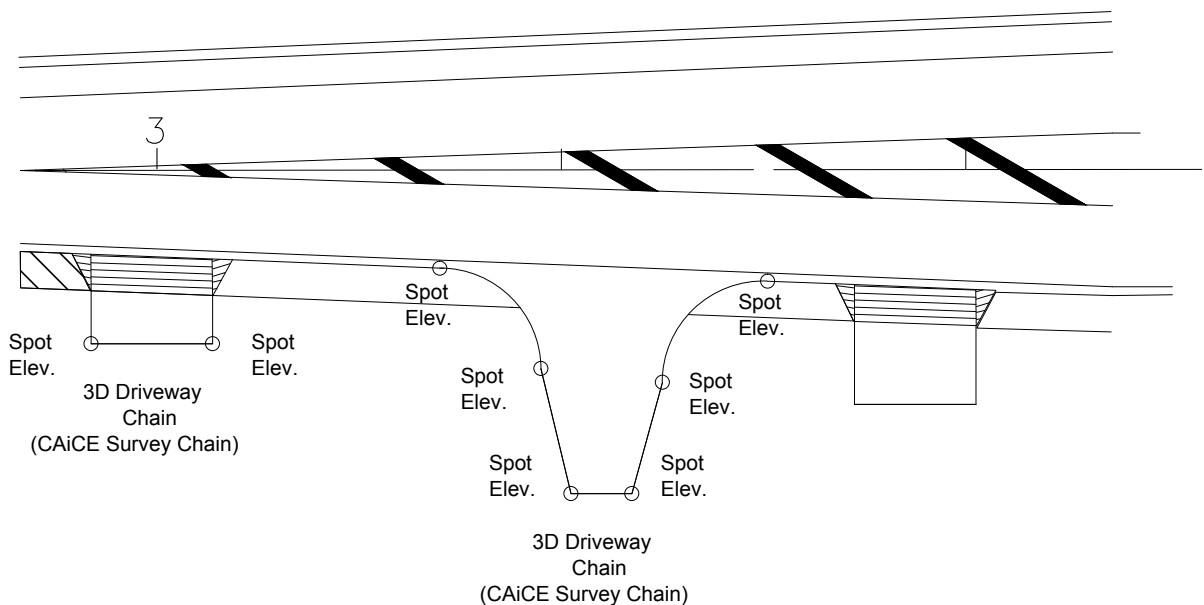

MoT Section	1270		TAC Section	Not Applicable
-------------	------	--	-------------	----------------

The basic naming convention that must be used is to prefix the survey chain with the alignment name, the proposed feature code “PDW” (proposed driveway) and left or right side. The designer must assign the survey chain a feature of PDW. The designer should make full use of the description field if there is additional information needed to describe the element beyond what is required by the element naming convention.

100PDWR117, 100PDWL57, etc.

- **Advanced Driveway Design**

If the difference in grade, the length of driveway and driveway complexity warrant an actual driveway design, then the same design practices as utilized for minor or sideline roads should be used and identified as a minor or sideline alignment design.

Right of Way Geometry Chains

Archive Requirement

- Preliminary Design – No
- Functional Design – No (Unless used in VRS file)
- Detailed Design – Yes
- Construction – Yes

The basic naming convention that must be used is to prefix the geometry chain name with “PRW”. The designer must assign the geometry chain a feature of PRW. The designer should make full use of the description field if there is additional information needed to describe the element beyond what is required by the element naming convention.

PRW43, PRW57, etc.

Right of way geometry chains must not be closed (not cross a roadway) at any of the limits of construction and therefore the project may require the creation of multiple right of way geometry chains.

MoT Section	1270		TAC Section	Not Applicable
-------------	------	--	-------------	----------------

T.L.C.A. Temporary License for Construction Access Geometry Chains

Archive Requirement

- Preliminary Design – No
- Functional Design – No (Unless used in VRS file)
- Detailed Design – Yes
- Construction – Yes

The basic naming convention that must be used is to prefix the geometry chain name with “PTLCA”. The designer must assign the geometry chain a feature of PTLCA. The designer should make full use of the description field if there is additional information needed to describe the element beyond what is required by the element naming convention.

PTLCA32, PTLCA46, etc.

T.L.C.A. temporary license for construction geometry chains must not be closed (not cross a roadway) at any of the limits of construction and therefore the project may require the creation of multiple T.L.C.A. geometry chains.

Clearing and Grubbing Geometry Chains

Archive Requirement

- Preliminary Design – No
- Functional Design – No (Unless used in VRS file)
- Detailed Design – Yes
- Construction – Yes

The basic naming convention that must be used is to prefix the geometry chain name with “PCLGR”. The designer must assign the geometry chain a feature of PGC. The designer should make full use of the description field if there is additional information needed to describe the element beyond what is required by the element naming convention.

PCLGR18, PCLGR23, etc.

Clearing and grubbing geometry chains must not be closed (not cross a roadway) at any of the limits of construction and therefore the project may require the creation of multiple clearing and grubbing geometry chains.

MoT Section	1270	TAC Section	Not Applicable
-------------	------	-------------	----------------

Cut/Fill Toe Geometry Chains

Archive Requirement

- Preliminary Design – Yes
- Functional Design – Yes
- Detailed Design – Yes
- Construction – Yes

The basic naming convention that must be used is to prefix the geometry chain name with the alignment name, one of three proposed feature codes “PTC” (proposed toe of cut), “PTF” (proposed toe of fill), “PTO” (proposed toe) and left or right side. The designer must assign the geometry chain a feature of PTC, PTF or PTO. The designer should make full use of the description field if there is additional information needed to describe the element beyond what is required by the element naming convention.

100PTCL23, 100PTFR43, 100PTOL76, etc.

Vertical Cutoff Geometry Chains

Archive Requirement

- Preliminary Design – No
- Functional Design – Yes
- Detailed Design – Yes
- Construction – Yes

The basic naming convention that must be used is to prefix the geometry chain name with the alignment name, the proposed feature code “PVC” (proposed vertical cutoff) and left or right side. The designer must assign the geometry chain a feature of PVC. The designer should make full use of the description field if there is additional information needed to describe the element beyond what is required by the element naming convention.

100PVCL12, 100PVCR27, etc.

Gutter Geometry Chains

Archive Requirement

- Preliminary Design – No
- Functional Design – No (Unless used in VRS file)
- Detailed Design – Yes
- Construction – Yes

The basic naming convention that must be used is to prefix the geometry chain name with the alignment name, the proposed feature code “PGU” (proposed gutter) and left or right side. The designer must assign the geometry chain a feature of PGU. The designer should make full use of the description field if there is additional information needed to describe the element beyond what is required by the element naming convention.

100PGUR87, 100PGUL99, etc.

MoT Section	1270		TAC Section	Not Applicable
-------------	------	--	-------------	----------------

Back of Sidewalk (Outermost) Geometry Chains

Archive Requirement

- Preliminary Design – No
- Functional Design – No (Unless used in VRS file)
- Detailed Design – Yes
- Construction – Yes

The basic naming convention that must be used is to prefix the geometry chain name with the alignment name, the proposed feature code “PSW” (proposed sidewalk) and left or right side. The designer must assign the geometry chain a feature of PSW. The designer should make full use of the description field if there is additional information needed to describe the element beyond what is required by the element naming convention.

100PSWR14, 100PSWL53, etc.

Barrier (Not Controlled by Edge of Pavement) Geometry Chains

Archive Requirement

- Preliminary Design – No
- Functional Design – No (Unless used in VRS file)
- Detailed Design – Yes
- Construction – Yes

The designer must describe the insertion point, insertion left side, centre or right side of barrier in the CAiCE Design Project Data Archive Log File.

The basic naming convention that must be used is to prefix the geometry chain name with the alignment name and the proposed feature code “PNEB” (proposed barrier). The designer must assign the geometry chain a feature of PNEB. The designer should make full use of the description field if there is additional information needed to describe the element beyond what is required by the element naming convention.

100PNEB34, 100PRNEB147, etc.

Island Curb (Curb and Pavement Intersect) Geometry Chains

Archive Requirement

- Preliminary Design – No
- Functional Design – No (Unless used in VRS file)
- Detailed Design – Yes
- Construction – Yes

The basic naming convention that must be used is to prefix the geometry chain name with the alignment name and the proposed feature code “PIC” (proposed island curb). The designer must assign the geometry chain a feature of PIC. The designer should make full use of the description field if there is additional information needed to describe the element beyond what is required by the element naming convention.

100PIC47, 100PIC253, etc.

MoT Section	1270		TAC Section	Not Applicable
-------------	------	--	-------------	----------------

Asphalt Curb (Curb and Pavement Intersect) Geometry Chains

Archive Requirement

- Preliminary Design – No
- Functional Design – No (Unless used in VRS file)
- Detailed Design – Yes
- Construction – Yes

The basic naming convention that must be used is to prefix the geometry chain name with the alignment name and the proposed feature code “PAC” (proposed asphalt curb). The designer must assign the geometry chain a feature of PAC. The designer should make full use of the description field if there is additional information needed to describe the element beyond what is required by the element naming convention.

100PAC47, 100PAC253, etc.

Raised Median Curb (Curb and Pavement Intersect) Geometry Chains

Archive Requirement

- Preliminary Design – No
- Functional Design – No (Unless used in VRS file)
- Detailed Design – Yes
- Construction – Yes

The basic naming convention that must be used is to prefix the geometry chain name with the alignment name and the proposed feature code “PRMC” (proposed raised median curb). The designer must assign the geometry chain a feature of PRMC. The designer should make full use of the description field if there is additional information needed to describe the element beyond what is required by the element naming convention.

100PRMC48, 100PRMC254, etc.

Concrete Median Centre Divider Geometry Chains

Archive Requirement

- Preliminary Design – No
- Functional Design – No (Unless used in VRS file)
- Detailed Design – Yes
- Construction – Yes

The basic naming convention that must be used is to prefix the geometry chain name with the alignment name and the proposed feature code “PMC” (proposed median centre). The designer must assign the geometry chain a feature of PMC. The designer should make full use of the description field if there is additional information needed to describe the element beyond what is required by the element naming convention.

100PMC26, 100PMC365, etc.

MoT Section	1270		TAC Section	Not Applicable
-------------	------	--	-------------	----------------

Storm Drain / Storm Sewer Line Pipe Geometry Chains

Archive Requirement

- Preliminary Design – No
- Functional Design – No (Unless used in VRS file)
- Detailed Design – Yes
- Construction – Yes

The basic naming convention that must be used is to prefix the geometry chain name with the proposed feature code “PDS”. The designer must assign the geometry chain a feature of PDS. The designer should make full use of the description field if there is additional information needed to describe the element beyond what is required by the element naming convention.

PDS25, PDS342, etc.

Sanitary Sewer Line Pipe Geometry Chains

Archive Requirement

- Preliminary Design – No
- Functional Design – No (Unless used in VRS file)
- Detailed Design – Yes
- Construction – Yes

The basic naming convention that must be used is to prefix the geometry chain name with the proposed feature code “PSU”. The designer must assign the geometry chain a feature of PSU. The designer should make full use of the description field if there is additional information needed to describe the element beyond what is required by the element naming convention.

PSU13, PSU134, etc.

Water Line Pipe Geometry Chains

Archive Requirement

- Preliminary Design – No
- Functional Design – No (Unless used in VRS file)
- Detailed Design – Yes
- Construction – Yes

The basic naming convention that must be used is to prefix the geometry chain name with the proposed feature code “PWR”. The designer must assign the geometry chain a feature of PWR. The designer should make full use of the description field if there is additional information needed to describe the element beyond what is required by the element naming convention.

PWR17, PWR589, etc.

MoT Section	1270		TAC Section	Not Applicable
-------------	------	--	-------------	----------------

Report Files

Archive Requirement

- Preliminary Design – No
- Functional Design – Yes
- Detailed Design – Yes
- Construction – Yes

These include such reports as volumes, horizontal alignment, vertical alignment, superelevation, cross section design logs etc. When creating design related report files, they must be generated using descriptive names that relate directly to the design function performed and the data being used.

Any reports produced in CAiCE for the hardcopy design folders must be retained in the CAiCE project saved in their appropriate alignment folder.

Parameter Files

Archive Requirement

- Preliminary Design – No
- Functional Design – Yes
- Detailed Design – Yes
- Construction – Yes

When using a CAiCE command or BCMoT macro and an option is used to save the parameter settings (.INI, .TXT, PXS, PPF etc.) for repetitive use, then they must be generated using descriptive names that directly relate to the design function performed and the data being used.

1270.09 ZONE DESIGNATIONS

Archive Requirement

- Preliminary Design – Yes
- Functional Design – Yes
- Detailed Design – Yes
- Construction – Yes

CAiCE zones are a method of segregating data within a design project that can be used to select information for viewing, editing, reporting etc. The designer must use only zones 101-499. Zone numbers 1-100 will be used for survey and zones 500 and above will be used for construction supervision purposes.

For survey data, surveyors must make use of these working zones to segregate individual survey segments because of the CAiCE restriction that when elements are edited they are automatically removed from the original segment.

The CAiCE Design Project Data Archive Log File Generator macro described in [Section 1270.06](#) populates the log file spreadsheet with all zones found in the CAiCE project. The zones identified in the log file must be supplemented with sufficient descriptive detail by the designer so that construction supervision staff and anyone reviewing the completed design can understand what zones have been utilized and what is contained in each zone.

MoT Section	1270		TAC Section	Not Applicable
-------------	------	--	-------------	----------------

For the CAiCE project data archives, zone assignments must be made as follows to provide an easy method of isolating data within the final design.

Major Alignment and Associated Details

The major horizontal alignment and its associated detail must be assigned to a specific range of zones within zones 101 to 499. Associated details may include, but are not limited to the following:

- Design profile L100A1P1 etc.
- All related design fragment application profiles 100PDCR75, 100PBEL88, etc.
- All related ditch horizontal alignments D10, D11, D12, etc.
- All related structure horizontal alignments S20, S21, S22, etc.
- All related design fragment application geometry chains 100PSHR65, 100PLEL79, etc.
- All 3D driveway chains (CAiCE survey chains) 100PDWR117, 100PDWL57, etc.
- All related right of way geometry Chains PRW43, PRW57, etc.
- All related temporary license for construction access geometry chains PTLCA32, PTLCA46, etc.
- All related clearing and grubbing geometry chains PCLGR18, PCLGR23, etc.
- All related cut/fill toe geometry chains 100PTCL23, 100PTFR43, 100PTOL76, etc.
- All related vertical cutoff geometry chains 100PVCL12, 100PVCR27, etc.
- All gutter geometry chains 100PGUR87, 100PGUL99, etc.
- All back of sidewalk (outermost) geometry chains 100PSWR14, 100PSWL53, etc.
- All barrier (not controlled by edge of pavement) geometry chains 100PNEB34, 100PNEB147, etc.
- All island curb (curb and pavement intersect) geometry chains 100PIC47, 100PIC253, etc.
- All asphalt curb (curb and pavement intersect) geometry chains 100PAC47, 100PAC253, etc.
- All raised median curb (curb and pavement intersect) geometry chains 100PRMC48, etc.
- All concrete median centre divider (curb and pavement intersect) geometry chains 100PMC26, etc.
- All related storm drain / storm sewer line pipe geometry chains PDS25, PDS342, etc.
- All related sanitary sewer line pipe geometry chains PSU13, PSU134, etc.
- All related water line pipe geometry chains PWR17, PWR589, etc.
- All related geometry chains not identified above
- All related superelevation lines L100A1SE, etc.
- All related design generated points 100PLER1, 100PEPL1, etc.

Minor, Sideline and Access/Intersection Curve Horizontal Alignment and Associated Details

Each minor, sideline and access/intersection curve horizontal alignment and its associated detail must be assigned to its own specific range of zones. Associated details would normally be the same as what has been described above for the major horizontal alignment.

MoT Section	1270	TAC Section	Not Applicable
-------------	------	-------------	----------------

1270.10 DESIGN PROJECT DATA ARCHIVE: PREPARATION

Archive Requirement

- Preliminary Design – Yes
- Functional Design – Yes
- Detailed Design – Yes
- Construction – Yes

The Survey Project Data Archive and Survey Project Data Archive Log File as required by the CAiCE Survey Project Data Format TOR will be kept separate from the design project archives and log files. Only a clean copy of the project survey (survey, mapping, 3DLaser, LiDAR) database elements, related survey DTM databases and related survey DTMs, are to be included in the design project archive files.

A copy of the CAiCE Survey Project Data Archive and CAiCE Survey Project Data Archive Log File must be supplied with all completed design project archives and log files on separate CD.

A project archive file is the standard format used by the Ministry to retain completed projects in a repository of engineering data that can be easily utilized in the future. The archive file is also the format used to transfer completed projects from the designer to a construction supervision office, whether that design has been completed by the Ministry or by a design consultant. The designer after completing the design assignment, depending on the project lifecycle phase, must supply a PRELIMINARY DESIGN , FUNCTIONAL DESIGN, DETAILED DESIGN and/or CONSTRUCTION archive(s) submitted on compact disk.

Project data archive preparation should be based on the strict adherence to the project data archive content and naming conventions detailed in the following sections:

[1270.05 Design Project: Folders and Organization](#)

[1270.07 Design Project Data Archive: CDG Files](#)

[1270.08 Design Project Data Archive: Content and Naming Conventions](#)

MoT Section	1270	TAC Section	Not Applicable
-------------	------	-------------	----------------

To assist the designer with cleaning up their CAiCE project data prior to the creation of an archive file, the Ministry has developed a CAiCE Project Cleanup macro. This macro can be used to clean up CAiCE project folders, files and database elements. The macro will display a list of all files in the CAiCE project with an explanation of each file. The folders and files can be sorted by different criteria and folders and/or files can be deleted that are not required in the archive. The macro provides the capabilities to display project database elements sorted by various criteria and delete any that are not required in the archive.

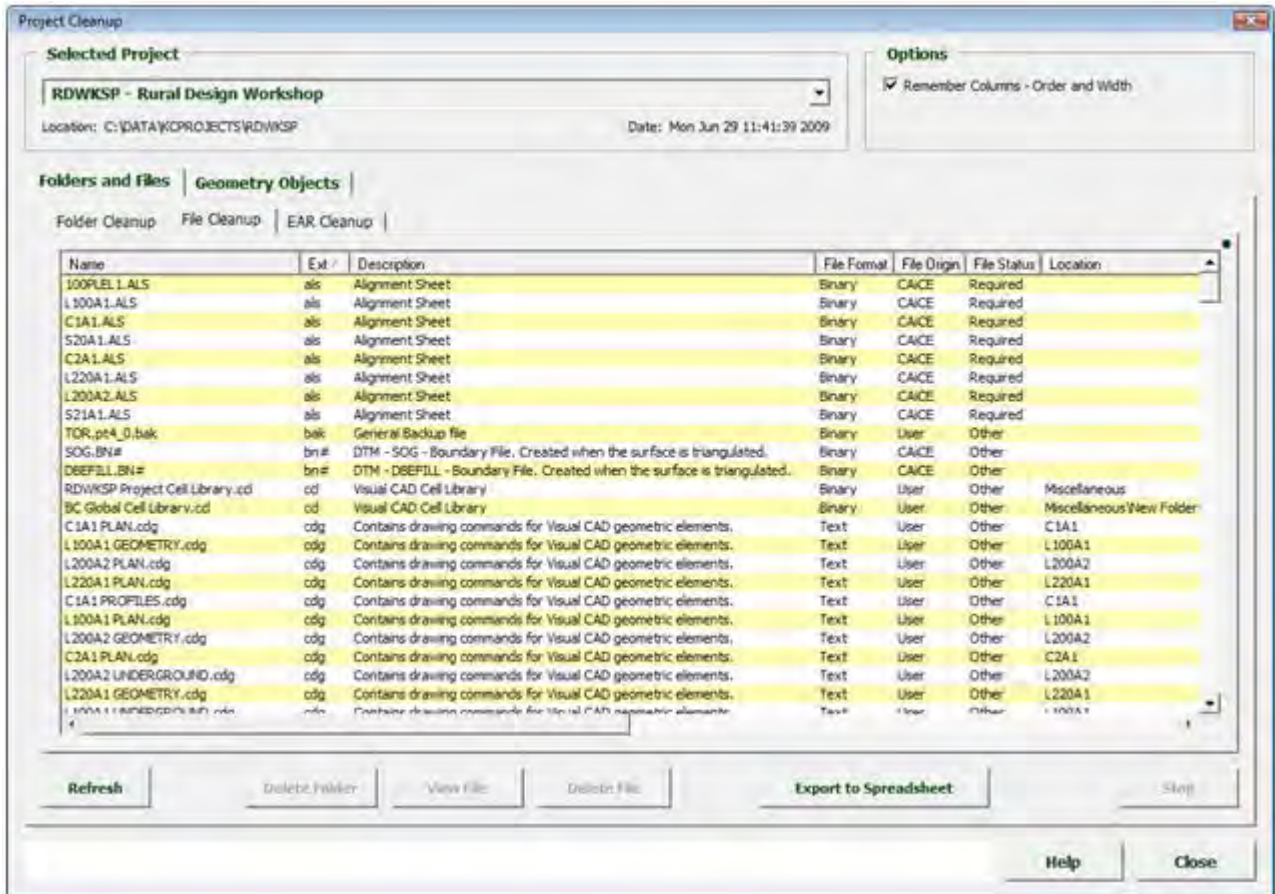

PRELIMINARY, FUNCTIONAL and DETAILED DESIGN Archive

The PRELIMINARY, FUNCTIONAL and DETAILED DESIGN archive files are required by the Ministry to retain an electronic record of all additional design options/alternatives included in the contract design report. These options/alternatives will include anything shown to the public, municipal councils and prepared as part of the environmental review process.

The archive file name must be prefixed by the project name, design type and “DESIGN”:

- @@@@@@-PRELIMINARY DESIGN.ZIP
- @@@@@@-FUNCTIONAL DESIGN.ZIP
- @@@@@@-DETAILED DESIGN.ZIP

MoT Section	1270		TAC Section	Not Applicable
-------------	------	--	-------------	----------------

CONSTRUCTION Archive

The CONSTRUCTION archive containing only the final design is required by the Ministry as a detailed record of the final design and to provide the necessary information for Ministry construction supervision purposes.

The CONSTRUCTION archive file must be cleaned up so that it only contains the final design and related work. All data related to preliminary iterations or rejected design alternatives must be deleted from the project database and project folders.

The data that is to be deleted will typically include, but not be limited to, items such as:

- CAiCE database elements such as horizontal alignments, geometry chains, profiles, design points, superelevation lines, cross section scanlines, etc.
- CAiCE project files such as design/template VRS/VRD, earthwork classification table, report, text, etc.

It is important to note that the designer must ensure that all relevant data that is used by the final design VRS files, to generate the final design cross section EAR files, are not deleted. This will include items such as the horizontal alignments, design profiles, fragment application geometry chains and fragment application profiles.

The archive file name must be prefixed by the project name and “CONSTRUCTION”:

@@@@@@-CONSTRUCTION.ZIP

The consultant must provide a completed Design Project Electronic Deliverables Quality Checklist as detailed in [Section 1270.13](#).

1270.11 CONTRACT DRAWINGS

Typical Sections

As all designs must be completed as described in the CAiCE Design Project Data Format Policy: Terms of Reference document, contract typical section drawings must be based on the designs completed in CAiCE and the corresponding content of the design cross section EAR files.

Any typical section exceptions that do not directly relate to the requirements of these terms of reference must be noted in the design project data archive project log file.

Contract AutoCAD DWG Drawings

Contract design drawings and location survey plan drawings must be saved to a separate compact disk other than the one(s) supplying the CAiCE design project archive files. The compact disk must utilize subfolders to separate major classes of drawings such as plans, profiles, typical sections etc.

Contract drawings that represent horizontal alignments must have the horizontal alignment names match the names used within the CAiCE design project. This will ensure consistency between CAiCE designs and the resulting contract drawings.

1270.12 CONTRACT MATERIAL VOLUMES

All final design neat line volumes must be calculated directly from CAiCE design cross sections only.

MoT Section	1270	TAC Section	Not Applicable
-------------	------	-------------	----------------

1270.13 DESIGN PROJECT ELECTRONIC DELIVERABLES: QUALITY CHECKLIST

The designer must provide a completed and signed Design Project Electronic Deliverables Quality Checklist to ensure that the project has been reviewed and that the CAiCE Design Project Data Format Policy: Terms of Reference requirements have been met.

Checklist items refer to specific sections of the CAiCE Design Project Data Format Policy: Terms of Reference and must be initialled by the designer or marked as N/A if the item does not apply to the specific design assignment.

To establish a standard for the creation of all Design Project Electronic Deliverable Quality Checklists, the Ministry has developed the Design Project Electronic Deliverables Quality Checklist Generator macro that will generate an EXCEL spreadsheet checklist.

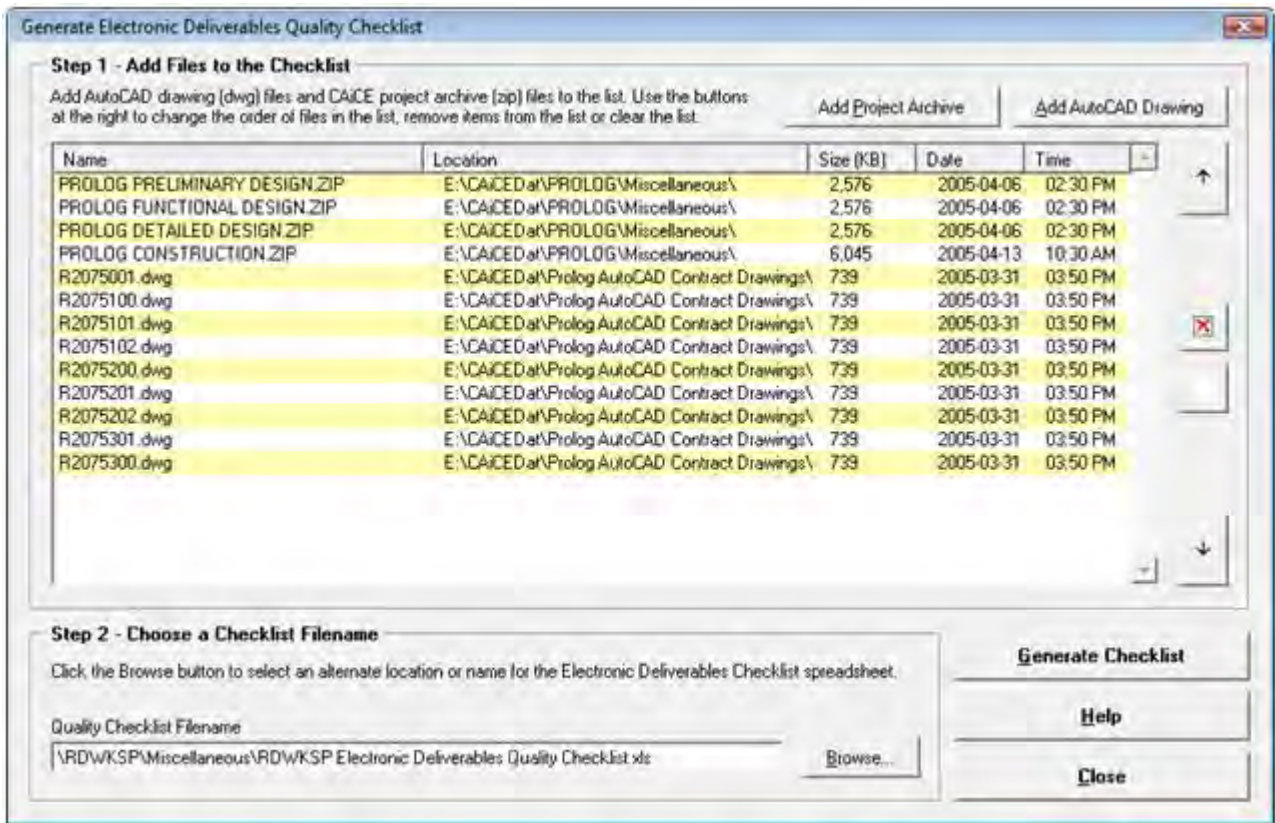

MoT Section	1270		TAC Section	Not Applicable
-------------	------	--	-------------	----------------

Designer Initials

Project Folders and Organization	_____
Project Data Archive Project Log Files	_____
Project Data Archive CDG Files	_____
Project Data Archive Content and Naming Conventions	
CAiCE Project Name	_____
Design Project Specific Feature Table and Cell Library File	_____
Cadastral	_____
Plan Detail	_____
CAiCE Database Element and File Naming Descriptions	_____
Horizontal Alignment Geometry Chains	_____
Horizontal Alignment Elements	_____
Design Element Feature Codes	_____
Superelevation Lines	_____
Cross Section Stations Text Files	_____
DTM Naming	_____
Data Source and Extent Boundary Definition	_____
Terrain Profile PFS Files	_____
Base Cross Section EAR Files	_____
Design Profiles	_____
Design Cross Section EAR Files	_____
Design Cross Section Surface Names	_____
Generic Link Design Cross Section Surface Names	_____
Design Fragment Application Geometry Chains	_____
Design Generated Points	_____
Design Fragment Marked Point Names	_____
Design Fragment Application Profiles	_____
Design VRS Files	_____
Design Earthwork Classification Tables Files	_____
Driveway Requirements	_____
Right of Way Geometry Chains	_____
T.L.C.A. Temporary License for Construction Access Geometry Chains	_____
Clearing and Grubbing Geometry Chains	_____
Cut/Fill Toe Geometry Chains	_____
Vertical Cutoff Geometry Chains	_____
Gutter Geometry Chains	_____
Back of Sidewalk (Outermost) Geometry Chains	_____
Barrier (Not Controlled by Edge of Pavement) Geometry Chains	_____
Island Curb (Curb and Pavement Intersect) Geometry Chains	_____
Asphalt Curb (Curb and Pavement Intersect) Geometry Chains	_____
Raised Median Curb (Curb and Pavement Intersect) Geometry Chains	_____
Concrete Median Centre Divider Geometry Chains	_____
Storm Drain / Storm Sewer Line Pipe Geometry Chains	_____
Sanitary Sewer Line Pipe Geometry Chains	_____
Water Line Pipe Geometry Chains	_____
Report Files	_____
Parameter Files	_____
Zone Designations	_____
Project Data Archive Preparation	
Preliminary Design Archive	_____
Functional Design Archive	_____
Detailed Design Archive	_____
Construction Archive	_____
Contract Drawings	
Typical Sections	_____
Contract AutoCAD DWG Drawings	_____
Contract Material Volumes	_____

MoT Section	1270		TAC Section	Not Applicable
-------------	------	--	-------------	----------------

The designer must complete the tables on the following pages identifying the Design Project CAiCE and AutoCAD Contract Drawing Electronic Deliverables that are being provided with the completed design assignment.

The Design Project CAiCE Electronic Deliverables table identifies the CAiCE Project Data Archives file name, file size, date/ time the file was created and the initials of the designer that has generated the archive files. Design revisions and the resultant CAiCE Design Project Data Archive versions, must be added to the table and the revised Design Project Electronic Deliverables Quality Checklist provided with the revised Design Project CAiCE Electronic Deliverables. An example table has been provided in this section.

For the Design Project CAiCE Electronic Deliverables table, any entries that identify a new version of a CAiCE Project Data Archive File should be documented in the Design Project Data Archive Project Log File. The designer must provide sufficient detail to allow anyone reviewing the project to understand why revisions have been made and, specifically related to construction, what new CAiCE database elements and files have been created or revised.

The Design Project AutoCAD Contract Drawing Electronic Deliverables table identifies the AutoCAD Drawings file name, file size, data/time the file was created and the initials of the designer that has generated the drawing files. Design revisions and the resultant AutoCAD Contract Drawing versions, must be added to the table and a revised Design Project Electronic Deliverables Quality Checklist provided with the revised Design Project AutoCAD Drawing Electronic Deliverables. An example table has been provided in this section.

MoT Section	1270	TAC Section	Not Applicable
-------------	------	-------------	----------------

Design Project CAiCE Electronic Deliverables Table

Rev	CAiCE Project Data Archive File Name	Size (KB)	Date (yyyy-mm-dd)	Time (### am/pm)	Designer Initials

Design Project AutoCAD Contract Drawing Electronic Deliverables Table

Rev	AutoCAD Contract Drawing File Name	Size (KB)	Date (yyyy-mm-dd)	Time (### am/pm)	Designer Initials

Checklist Verification

Design Office: _____

Designer Name and Signature: _____

Date Signed: _____

Reviewed By: _____

Date Reviewed: _____

MoT Section	1270	TAC Section	Not Applicable
-------------	------	-------------	----------------

Example Design Project CAiCE Electronic Deliverables Table

Rev	CAiCE Project Data Archive	Size (KB)	Date (yyyy-mm-dd)	Time (#:## am/pm)	Designer Initials
	@@@@@-PRELIMINARY DESIGN.ZIP	5,356	2005-02-05	1:15 pm	<i>JS</i>
	@@@@@-FUNCTIONAL DESIGN.ZIP	7,356	2005-03-05	2:15 pm	<i>JS</i>
	@@@@@-DETAILED DESIGN.ZIP	12,356	2005-04-05	3:15 pm	<i>JS</i>
	@@@@@-CONSTRUCTION.ZIP	9,356	2005-05-05	4:15 pm	<i>JS</i>
A	@@@@@-DETAILED DESIGN.ZIP	12,356	2005-04-05	3:15 pm	<i>JS</i>
A	@@@@@-CONSTRUCTION.ZIP	9,356	2005-05-05	4:15 pm	<i>JS</i>

Example Design Project AutoCAD Contract Drawing Electronic Deliverables Table

Rev	CAiCE Project Data Archive	Size (KB)	Date (yyyy-mm-dd)	Time (#:## am/pm)	Designer Initials
	R2075001.DWG	5,356	2005-02-05	1:15 pm	<i>JS</i>
	R2075100.DWG	7,356	2005-03-05	2:15 pm	<i>JS</i>
	R2075200.DWG	12,356	2005-04-05	3:15 pm	<i>JS</i>
	R2075300.DWG	9,356	2005-05-05	4:15 pm	<i>JS</i>
A	R2075200.DWG	5,356	2005-02-05	1:15 pm	<i>JS</i>
A	R2075300.DWG	7,356	2005-03-05	2:15 pm	<i>JS</i>

MoT Section	1270		TAC Section	Not Applicable
-------------	------	--	-------------	----------------

This page is intentionally blank