

MoT Section	1500		TAC Section	Not Applicable
-------------	------	--	-------------	----------------

## 1500 ALPINE SKI VILLAGE ROADS CHAPTER

### 1510 ALPINE SKI VILLAGE ROAD CONSTRUCTION SPECIFICATIONS.. 1510-1

1510.00	Preamble .....	1510-1
1510.01	General.....	1510-1
1510.02	Clearing and Grubbing.....	1510-5
1510.03	Roadway Drainage Excavation.....	1510-5
1510.04	Earth Embankments .....	1510-5
1510.05	Rock Embankments .....	1510-5
1510.06	Special Slope Treatments.....	1510-5
1510.07	Granular Surfacing, Base and Sub-bases .....	1510-5
1510.08	Construction.....	1510-7
1510.09	Storm Drainage .....	1510-7
1510.10	Cul-de-sacs and Hammerheads.....	1510-8
1510.11	Paving .....	1510-8

### 1520 ALPINE SKI VILLAGE ROAD DESIGN PARAMETERS ..... 1520-1

1520.01	Considerations.....	1520-1
1520.02	Road Classification .....	1520-1
1520.03	Drawings .....	1520-1
1520.04	Accommodating Pedestrians and Cyclists .....	1520-2
1520.05	Snow Storage .....	1520-2
1520.06	On-Street Parking.....	1520-3
1520.07	Alignment .....	1520-5
1520.08	Intersections/Accesses .....	1520-13
1520.09	Utility Setback .....	1520-13
1520.10	Driveways .....	1520-14
1520.11	Bridges .....	1520-17
1520.12	Signing .....	1520-17
1520.13	Speed.....	1520-17
1520.14	Overhead Clearance .....	1520-17

MoT Section	1500	TAC Section	Not Applicable
-------------	------	-------------	----------------

**1500 ALPINE SKI VILLAGE ROADS CHAPTER  
TABLES**

1510.A	Right-of-Way Width.....	1510-3
1520.B	Design Parameters .....	1520-5
1520.C	Finished Top and Shoulder Widths.....	1520-5

**1500 ALPINE SKI VILLAGE ROADS CHAPTER  
FIGURES**

1510.A	Right-of-Way Requirements.....	1510-4
1520.A	On-Street Parking.....	1520-4
1520.D	Typical Two-Lane, Curb and Gutter, Alpine Ski Village Road .....	1520-6
1520.E	Typical Two-Lane, Paved, Open Shoulder, Alpine Ski Village Road .....	1520-7
1520.F	Typical Two-Lane, Gravel, Open Shoulder, Alpine Ski Village Road .....	1520-8
1520.G	Collector/Local Open Shoulder Cul-de-sac .....	1520-10
1520.H	Collector/Local Curb and Gutter Cul-de-sac .....	1520-11
1520.I	Typical Hammerhead.....	1520-12
1520.J	Modified Hammerhead .....	1520-12
1520.K	Culvert Installation.....	1520-15
1520.L	Driveway Cross Section.....	1520-15
1520.M	Driveway and Culvert Installation Layout.....	1520-16

MoT Section	1510	TAC Section	Not Applicable
-------------	------	-------------	----------------

# 1510 ALPINE SKI VILLAGE ROAD CONSTRUCTION SPECIFICATIONS

Where there are existing agreements the Ministry of Transportation (MoT) and other parties, those agreements shall prevail. Where excerpts from the Standard Specifications for Highway Construction or from the BC Supplement to the TAC Geometric Design Guide are different from the said current version, the actual publications shall prevail.

These guidelines only apply to the construction of Alpine Ski Village roads. They do not apply to the construction of the access roads leading up to Alpine Ski Villages.

Exceptions to these guidelines shall be directed through the District Manager, Transportation to the Regional Director

## 1510.00 PREAMBLE

### 1510.00.01 Project Teams

For Districts regularly involved in alpine ski village road developments and approvals, a Project team should be created with the mandate of addressing ski village road developments. The Project team shall be responsible for setting the design criteria including the right-of-way requirements. A formal design criteria sheet shall be completed as part of the project documentation. The Project team should consist of a local developer(s) and/or consultant(s), a District development approvals representative\*, appropriate Regional engineering representative(s), appropriate District representative(s), a maintenance contractor representative and others, as is seen fit. This Project team could be put together on a project by project basis, although the creation of a permanent Project team would be more desirable.

\* *District development approvals representatives should liaise with Provincial Approving Officers.*

### 1510.00.02 Design Criteria Variance and Dispute Resolution Process

If exceptions to geometric design guidelines are desired, a design criteria sheet must be submitted to the Regional Manager of Engineering requesting approval. If the requested exception is a substantial variation from Ministry guidelines, the Regional Manager of Engineering may forward the criteria sheet to the Chief Engineer for a decision. The design criteria sheet shall list the MoT guidelines criteria and the proposed criteria along with supporting rationale of the variance signed by a Professional Engineer registered in British Columbia.

The District shall formally notify all parties when the dispute resolution process is initiated. Any disputes that arise within the Project team shall first be adjudicated by the Regional Manager of Engineering. If this adjudicated decision is not agreeable to both parties, it becomes the responsibility of the Proponent and District Manager Transportation or Regional Manager of Engineering to each prepare a "Briefing Note for Decision" that describes the issue and their recommendation. The Decision is to be signed off by the MoT Chief Engineer within 14 working days from the submission. The Chief Engineer may discuss the issues with Headquarters engineering staff, the Regional Manager of Engineering, the District and the Proponent, as he sees fit, for the purpose of clarification and decision. The formal decision shall be provided to the Proponent by the final sign off authority.

### 1510.01 GENERAL

1. All construction practices and procedures shall conform to the **current** edition of the Ministry's **Standard Specifications for Highway Construction** unless specified otherwise in the text below or by the Ministry Representative. Copies of the Standard Specifications can be obtained from the MoT website ([www.gov.bc.ca/tran](http://www.gov.bc.ca/tran)) by going to the Site Index, then to Standard Specifications.
2. The developer shall conform to the conditions contained in the Standard Specifications as well as any Special Provisions specified by the Ministry. These Special Provisions shall take precedence over the Standard Specifications.
3. The Developer must follow the Quality Management section of the Standard Specifications. For any construction started prior

MoT Section	1510	TAC Section	Not Applicable
-------------	------	-------------	----------------

to the District approval of design plans, the Developer must have an accepted Quality Control Plan and a Quality Control Manager in place. If not, the MoT may hire a 3<sup>rd</sup> party Quality Control engineer at the Developer’s expense.

4. Roadways shall not be accepted if any one of the following occurs:
  - a) If road construction has been undertaken during periods of snow, heavy rains, freezing, or other such unsuitable weather conditions.
  - b) If granular aggregate has been placed upon a frozen, wet, muddy, or rutted subgrade or base course.
  - c) If a design plan has not been accepted by the Ministry.
  - d) For reasons other than those outlined above, as per the discretion of the Ministry representative. Justification from the Ministry representative will be required if a roadway is not accepted.

**1510.01.01 Right-of-Way Width**

In order to optimize land use within an alpine ski development area, MoT is prepared to accept a “dedicated” right-of-way width sufficient to contain, but not limited to: roadway lanes, shoulders, parking aisles (if applicable), necessary utilities (including setbacks), dedicated snow storage aisles, and sidewalks. It is left to the Project team to discuss, define, and agree upon the extents of the dedicated right-of-way, including which roadway features are to be encompassed within this right-of-way width. The dedicated right-of-way must be viewed on an intersection to intersection basis only, rather than parcel by parcel, in order to maintain a consistent right-of-way width over the corridor.

In addition to the dedicated right-of-way width, there shall also be a requirement for a “statutory” right-of-way width. This statutory right-of-way is required at the developmental stage and must be of sufficient width to contain all works<sup>1</sup> plus 3 metres beyond the top of cut or toe of fill.

Based on the definitions outlined in the above paragraphs, the “total” right-of-way shall be defined as the dedicated right-of-way plus the statutory right-of-

<sup>1</sup> Includes, but not limited to: roadway lanes, shoulders, parking aisles (if applicable), necessary utilities (including setbacks), dedicated snow storage aisles, sidewalks, ditches, cut slopes, and fill slopes.

way (refer to Figure 1510.A). This total right-of-way will allow MoT to freely carry out its responsibilities to ensure a safe and effective roadway is maintained. This concept of total right-of-way (dedicated plus statutory) will require Project team flexibility in developing a mutually agreeable combination of both dedicated and statutory rights-of-way.

For zoning purposes, the intent is that the setback would be from the dedicated right-of-way; however, property owners will not be permitted to erect a building within the statutory right-of-way until the Ministry is satisfied that the cut and fill slopes adjacent to the road have been stabilized. The setback would either be the Provincial requirement of a minimum 5 metre building setback or the Regional District or local government setback requirement, whichever is greater.

As described above, the purpose of the statutory right-of-way is to provide MoT with unencumbered access to all parts of the roadway works to carry out any necessary maintenance or remedial works. If, after completion of the development infrastructure (i.e. residential, commercial construction), the property owners have fully resolved the Ministry’s concerns, the Ministry will then be prepared to have the statutory right-of-way released from the Title. Until this time, or if the property owner chooses not to stabilize or infill the slopes, the statutory right-of-way will remain registered against the Title to allow the Ministry continued access to the roadway works, if and when required.

The Ministry may consider the posting of the road rights-of-way and the statutory rights-of-way adjacent to Crown Land after construction, subject to assurances that the pinning will be completed after and upon satisfactory approval of the construction.

MoT concerns, including but not limited to: cut and fill sections, geotechnical instability, storm/flood hazards, future widening, and maintenance including snow/ice storage will need to be addressed prior to the release or partial release of the statutory right-of-way. These situations may require the construction of mitigative works, satisfactory to the Ministry, first being completed at the owner’s cost, before release or partial release of the statutory right-of-way would be considered.

MoT Section	1510		TAC Section	Not Applicable
-------------	------	--	-------------	----------------

See Table 1510.A for minimum right-of-way widths. These minimum widths were developed as guidelines based on the minimum width required to encompass a basic roadway cross-section. Provincial Approving Officers may request additional dedicated right-of-way width to ensure all roadway features are adequately encompassed within the dedicated right-of-way envelope.

*NOTE: Additional Right-of-Way may be required for bridges to adequately accommodate bridge guardrail flares.*

**Table 1510.A – Right-of-Way Width**

	<b>MINIMUM DEDICATED RIGHT-OF-WAY</b>
Local Urban	14 m
Local Rural	18 m
Collector Urban	18 m
Collector Rural	20 m

MoT Section	1510	TAC Section	Not Applicable
-------------	------	-------------	----------------

Figure 1510.A Right-of-Way Requirements

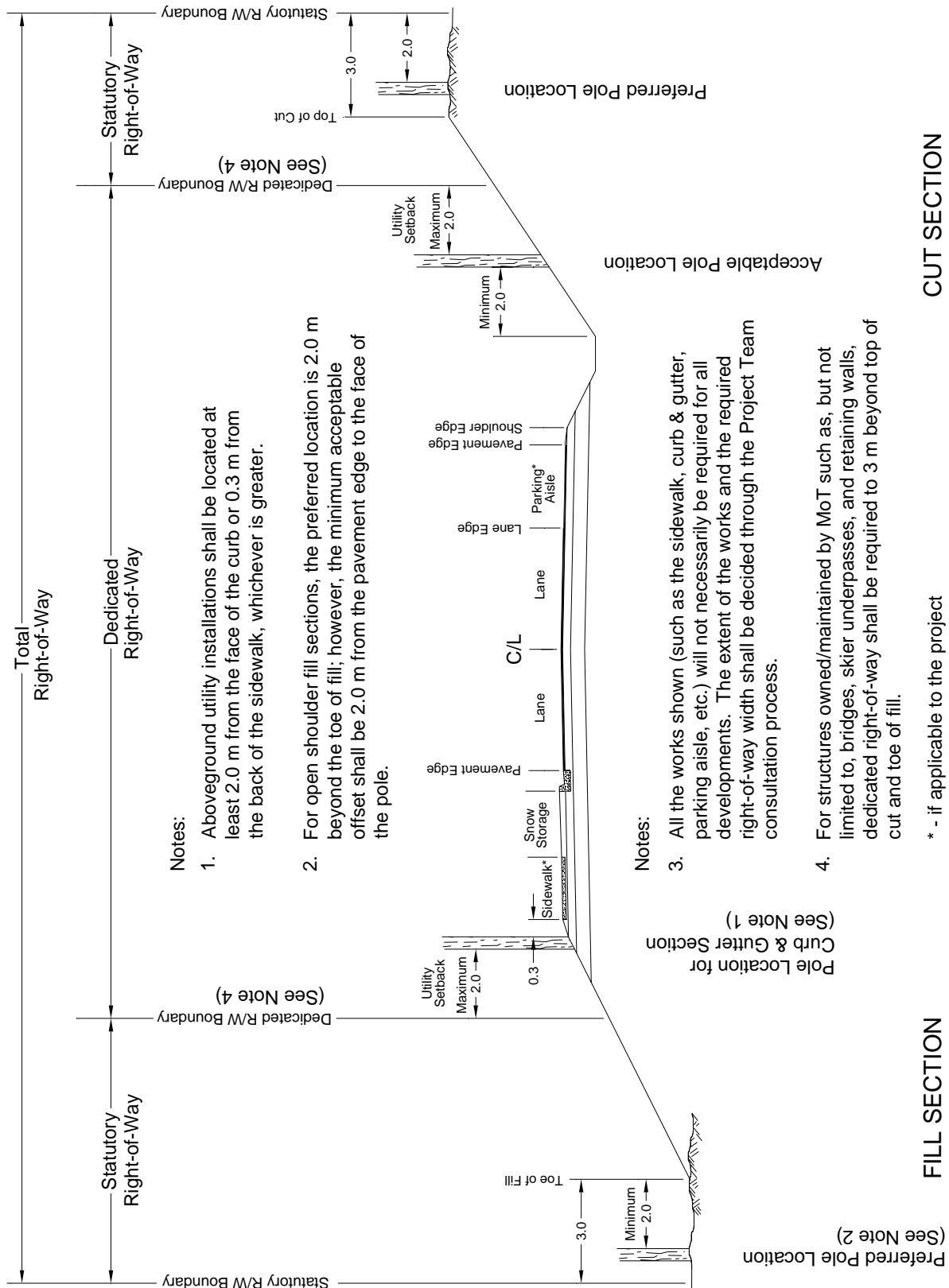

MoT Section	1510	TAC Section	Not Applicable
-------------	------	-------------	----------------

### 1510.01.02 Inspections

Inspections shall be carried out upon completion of each of the following stages of construction:

- a) Clearing and Grubbing and Subgrade Slope Staking
- b) Roadway and Drainage Excavation and Subgrade Construction Slope Stakes
- c) Select Granular Sub-Base Construction and Slope Stakes for Surface Course Construction
- d) Paving (when required)
- e) Completion (signs, pavement markings, etc.)

The developer shall give a minimum of one (1) week's notice prior to completion of each stage to allow for the scheduling of inspections. If required notice is not given, the roadways may not be accepted.

A Letter(s) of Assurance is required at the end of construction. This letter(s) must be signed on behalf of the Developer by the responsible Professional Engineer.

Testing and/or inspections shall be carried out by the Ministry representative. Testing and/or inspections by an independent testing agency with a qualified Professional Engineer or Limited Licensee, practicing in this scope of engineering and registered with APEGBC, shall be considered as an acceptable alternative if agreed to by the Ministry Representative and the Developer.

### 1510.01.03 Other Regulating Agencies

The developer shall comply with any and all statutory regulations and bylaws and all applicable Federal, Provincial, Regional District, and Improvement District regulations during construction work.

### 1510.01.04 Miscellaneous

All roads shall be slope staked as requested by the Ministry Representative.

All utility lines as part of new subdivisions shall be inspected by the Ministry Representative for appropriateness of location.

## 1510.02 CLEARING AND GRUBBING

Clearing and grubbing shall be in accordance with Section 200 of the Standard Specifications. No debris shall be buried within the fill.

*NOTE: Inspection and approval of clearing and grubbing by the Ministry Representative are required prior to proceeding with sub-grade construction.*

### 1510.03 ROADWAY DRAINAGE EXCAVATION

Roadway and Drainage Excavation shall be in accordance with Subsection 201.01 of the Standard Specifications.

### 1510.04 EARTH EMBANKMENTS

Earth embankments shall be in accordance with Subsections 201.37 and 201.38 of the Standard Specifications.

### 1510.05 ROCK EMBANKMENTS

Rock embankments shall be in accordance with Subsection 201.36 of the Standard Specifications.

### 1510.06 SPECIAL SLOPE TREATMENTS

Slopes shall be treated in accordance with Drawing SP201-01 in the Standard Specifications. Hydro seeding shall be done as directed by the Ministry Representative.

### 1510.07 GRANULAR SURFACING, BASE AND SUB-BASES

#### 1510.07.01 Aggregate Quality

Aggregate quality shall conform to Section 202 of the Standard Specifications.

#### 1510.07.02 Pavement Design Standards

Pavement structure shall be designed by a Registered Member of APEGBC with appropriate qualifications in geotechnical design. Technical Circular T-01/04 "Pavement Structure Design Guidelines" (available on-line at: <http://www.th.gov.bc.ca/publications/Circulars/lister.asp?set=Current&circ=T&year=2004>) shall be used by the pavement designer as a guide.

Four Design Standards, (Types A, B, C and D) based on general roadway classification, are used to categorize British Columbia's provincial road network. Twenty (20) year design Equivalent Single Axle Loads (ESALs) are the primary criteria used for selection of the guideline base.

MoT Section	1510		TAC Section	Not Applicable
-------------	------	--	-------------	----------------

For alpine ski village roads, Type “A” and Type “B” design standards are not applicable as the 20 year design criteria (> 100,000 ESAL) will not be met.

*NOTE: one ESAL = one standard axle load = 8,165 kg (18,000 lb.)(i.e. Benkelman Beam Truck)*

Applicable designs to be considered by the Pavement Designer are summarized as follows:

STANDARD TYPE	ROADWAY DESIGNATION	20 YEAR DESIGN ESAL CRITERIA
TYPE “C”	LOW VOLUME ROADS	< 100,000
TYPE “D”	SUBDIVISION ROADS	< 100,000

**1. TYPE “C”** (see Type “D” below)  
**LOW VOLUME ROADS**

**2. TYPE “D”** (See Figures 1520.D & E)  
**SUBDIVISIONS ROADS < 100,000 ESAL’s**

50 mm A.P.  
225 mm C.B.C (25 mm MAXIMUM size)  
S.G.S.B. (See 1510.07.03)

*NOTE: Gravel depths are the compacted measurements.*

**1510.07.03 Aggregate Gradation and Surfacing**

The Ministry Representative, in consultation with the Regional Geotechnical and Materials Engineer, may specify alternative designs than stated below in consideration of local soils and climatic conditions. Granular surfacing, base and sub bases shall be in accordance with Section 202 of the Standard Specifications.

Regional Geotechnical and Materials Engineers shall review alternate pavement design specifications and material selection on an individual project basis, if requested from the developer’s engineer with valid rationale.

There are typically two gravel courses for paved roads and three for gravel roads:

1. The lower course (S.G.S.B). shall consist as follows:
  - A minimum thickness of 300 mm of S.G.S.B. shall be applied over fine-grained subgrade (Unified Soils Classification System - ML-CL-OL-MH-CH-OH)
  - A minimum thickness of 150 mm of S.G.S.B. shall be applied over coarse grained subgrade (Unified Soils Classification System - GW-GP-GM-GC-SW-SP-SM-SC) where ground water

does not pose a drainage problem and frost penetration does not affect the structure.

- A minimum 150 mm S.G.S.B. shall be applied over rock.
- No S.G.S.B. is required in exceptional circumstances where the following criteria has been met:
  - Structural Design Criteria is satisfied and
  - Subgrade material consists of clean granular deposits that satisfy the S.G.S.B. gradation and construction criteria of Section 202 of the Standard Specifications.

*NOTE: All leveling materials applied directly to blasted rock cuts shall be of S.G.S.B. quality.*

2. For gravel roads, the mid course shall consist of 150 mm of 25 mm Crushed Base Course (C.B.C.) in accordance with Section 202 of the Standard Specifications.
3. For paved roads, the upper course shall consist of 225 mm of 25 mm C.B.C. in accordance with Section 202 of the Standard Specifications.

For gravel roads, the upper course shall consist of 150 mm of Crushed Surfacing Aggregate in

MoT Section	1510	TAC Section	Not Applicable
-------------	------	-------------	----------------

accordance with Section 202 of the Standard Specifications.

- Subject to local conditions, the Ministry Representative may request additional gravel depths or confirmation of pavement structure design as specified in **1510.07.02**.
- Roadways shall be graded and compacted with crossfall for road drainage as follows:
  - a) For paved roads - 0.02 m/m crossfall (normal crown) on tangents and appropriate superelevation as specified on curves.
  - b) For gravel roads - 0.04 m/m crossfall on tangents and appropriate superelevation as specified on curves.
- Gravel shall be spread and compacted in lifts not exceeding 150 mm in depth or as specified by the Ministry Representative. If requested by the Ministry Representative, water shall be applied during gravel compaction to achieve 100% proctor density as specified in Section 202 of the Standard Specifications.
- The owner/contractor shall hire a qualified inspector (see **1510.01.02**), to provide written confirmation of compliance with Section 202 of the Standard Specifications.

THE S.G.S.B. THICKNESS MUST BE ACCEPTED BY THE REGIONAL GEOTECHNICAL AND MATERIALS ENGINEER.

NOTE: *Inspection and approval by the Ministry Representative (or at their request, a qualified Professional Engineer or Limited Licensee practicing in this scope of engineering) of granular material used for each gravel course is required prior to placement of the upper gravel courses (see 1510.01.02)*

### 1510.08 CONSTRUCTION

All cut and fill slopes shall be designed by a registered member of APEGBC or Limited Licensee practicing in that scope of engineering. The following guidelines shall be considered:

1. Back (cut) slopes shall be 1.5:1 or flatter, except in sand or similar material which shall be 2:1 or flatter, unless otherwise specified by the Ministry Representative. For rock ditches refer to **Figure 1520.F**.
2. All embankment (fill) slopes shall be 2:1 or flatter. Slopes up to 1.5:1 shall be considered by the

Ministry Representative upon request and the appropriate documentation from the designer. The Ministry Representative must approve slopes steeper than 2:1 prior to construction. The Ministry will not unreasonably withhold approval.

3. All embankment materials and gravel base courses shall be laid in 150 mm lifts. The contractor should use the appropriate equipment required to obtain the compaction as specified in the Standard Specifications for Highway Construction. Watering shall be carried out as required to provide optimum water content during compaction. Grades containing soft spots will not be accepted until such sections have been excavated and backfilled with suitable material and compacted. Other methods of compaction will be considered by the Ministry Representative upon request and must be approved by the Ministry Representative prior to implementation.

### 1510.09 STORM DRAINAGE

#### 1510.09.01 General

When information is presented in two locations or publications, difficulties can arise if both are not synchronized for changes. Rather than run that risk, Drainage Design is discussed as part of Chapter 1000, Hydraulics and Structures of the *BC Supplement to TAC Geometric Design Guide*.

A detailed Master Drainage Plan must be submitted with the design drawings unless previously provided in a Master Plan. The construction shall be in accordance with the storm water practices identified in the Master Drainage Plan. An update to the Master Drainage Plan may be required if local drainage issues are not adequately addressed by the Plan.

Drainage shall be adequately designed and meet the satisfaction of the Ministry Representative. All ditches and storm drainage pipes are to be carried to a natural drainage course. The original drainage pattern for the site shall not be altered without permission of any government agency that may have regulatory jurisdiction.

Drainage easements or statutory Rights-of-Way may be required. Drainage easements shall be a minimum of 6 metres in width or as determined by the Ministry Representative.

1. Only Ministry approved Corrugated Steel, Concrete, PVC or High Density Polyethylene pipe may be used for storm sewers. PVC may be used for storm lines in the road but is not to be used for culverts.

MoT Section	1510	TAC Section	Not Applicable
-------------	------	-------------	----------------

2. The minimum size driveway culvert shall be 400 mm diameter with a minimum required cover of 300 mm. The minimum size culvert for a collector (network) road shall be 500 mm diameter with a minimum cover of 450 mm. The actual proposed culvert sizes must be determined by the calculated hydraulic requirements, but must be no smaller than the minimums mentioned above. See Table 1040.A for a comprehensive listing of minimum cover requirements for network roads. These minimum dimensions may be increased at the discretion of the Ministry Representative.
3. Culvert grade shall be a minimum of 0.5% percent unless otherwise approved by the Ministry Representative.
4. Culverts shall be bedded and backfilled within the subgrade zone with a fine graded gravel free of rock over 25 mm.
5. The ditch invert grade shall be a minimum of 150 mm below the bottom of select granular sub base but shall be deep enough to ensure adequate cover, regardless of pipe size. Design flood frequencies should be considered when determining the minimum depth of cover.
6. All cul-de-sacs and hammerheads must be drained and all accumulated drainage that is conveyed across private property shall be carried on registered easements or statutory Rights-of-Way.
7. The inlet and/or outlet of culverts subject to erosion shall have sandbags or a headwall respecting clear zone principles and shall not introduce a further hazard.

### 1510.09.02 Curb and Gutter

Installation of curb and gutter storm systems shall only be considered after full and complete consultation with the Project team outlined in **1510.00**.

If curb and gutter storm systems are decided on by the Project team, the following issues should be considered:

- Areas behind the curb and gutter shall have adequate snow storage within the Right-of-Way.
- Erosion control measures should be put into place to eliminate and/or limit damage from run off and/or snow melt behind the curb and gutter section.
- All commencement/terminal points of curbs and catch basins should be marked by sufficient means to prevent plow damage to curbs and allow catch basins to be easily located.

### 1510.09.03 Requirements for Drainage Design

The Ministry's design approach for alpine ski village storm drainage is such that all storm drainage facilities be designed according to the major/minor storm drainage concept, as per the *BC Supplement to TAC Geometric Design Guide*.

The alpine ski village Master Drainage Plan must provide sufficient information to allow the reviewer to understand the developer's objectives and to thoroughly assess the hydraulic impacts of the development.

Post development storm drainage issues may be handled on a site by site basis or, if the Master Drainage Plan addresses it, they may be handled on a broader system/sector wide basis.

### 1510.09.04 Hydrology and Design Flow Calculations

For Hydrology and Design Flow Calculations, see Section 1020 of the *BC Supplement to TAC Geometric Design Guide*.

*NOTE: Inspection and approval of drainage and subgrade construction are required prior to gravelling (see 1510.01.02).*

### 1510.10 CUL-DE-SACS AND HAMMERHEADS

Cul-de-sac or hammerhead turnarounds shall be constructed on all dead end roads that cannot be further extended or are not to be further extended until a future phase of construction. Construction shall be in accordance with **1520.07.04** of this Guideline.

*NOTE: Although Chapter 1400 of the BC Supplement to the TAC Geometric Design Guide stipulates that hammerhead turnarounds shall only be considered in place of cul-de-sacs in rural situations where it is reasonable to expect a road extension within five years, the same does not apply to alpine ski village developments, where hammerheads are allowed as a permanent feature.*

### 1510.11 PAVING

1. In most circumstances, priming will be required and surfaces shall be primed prior to paving in accordance with Subsection 501.31 of the Standard Specifications. Priming will not be required only in those situations whereby schedule concerns, due to unfavorable weather conditions, would override considerations of the time required for prime to be

MoT Section	1510		TAC Section	Not Applicable
-------------	------	--	-------------	----------------

distributed and set. Discussion should be undertaken with the Project team, outlined in **1510.00.01** of this Guideline, to determine which weather conditions would override the need for priming.

2. A 50 mm asphalt pavement thickness should be adequate for alpine ski village developments where traffic volumes are low and there is very little heavy truck traffic. An increase in the asphalt pavement thickness may be warranted in situations where traffic volumes are high, as determined by the Pavement Designer.
3. In rural areas, other methods of hard surfacing (such as seal coat) may be considered by the Ministry Representative.
4. Prior to paving, the developer shall contact the Pavement Designer to ensure that on-site inspection will take place before and during paving operations.
5. The decision to pave and the pavement design shall be as directed by the Pavement Designer.
6. Upon completion of paving, shoulders will consist of either 19 mm Shouldering Aggregate or 25 mm Well Graded Base Course. Compaction of the shouldering material shall be in accordance with the Standard Specifications.

MoT Section	1510		TAC Section	Not Applicable
-------------	------	--	-------------	----------------

**This page is intentionally  
left blank**

MoT Section	1520	TAC Section	Not Applicable
-------------	------	-------------	----------------

# 1520

## ALPINE SKI VILLAGE ROAD DESIGN PARAMETERS

### 1520.01 CONSIDERATIONS

A Road Network Plan is based on a hierarchy of streets that is related to the amount and type of traffic served. It takes into account such factors as public transit, shopping and community facilities, and other land uses. The changing nature of the area over time is also a major factor. The future requirements for the entire road network are considered when an alpine ski village application is evaluated.

- Proposed Road Network plans must be laid out in such a manner as to not compromise the mobility function of the major roads. These plans should be reviewed and accepted by the Ministry. Once a Master Plan has been accepted by the Ministry, a review is not required unless major changes have occurred to the Plan.
- Where possible, new developments should have at least two accesses, one to act as the main resort access and an additional access (which may be gated), to be used in case of emergency.
- Pedestrian and cyclist volumes should be considered. Walkways and cycling lanes should be provided where considered necessary and as shown in the development plan. Walkways and cycling lanes can be either along the road or separated within a trail network.

### 1520.02 ROAD CLASSIFICATION

#### 1520.02.01 Arterial/Primary

Ski resort access roads shall be considered as arterial/primary roads and will not be discussed in these guidelines. Refer to T-circular 01/98 "Guidelines for the Determination of the Geometric Design Criteria for Access Roads to Ski Resorts" (available on-line at: <http://www.th.gov.bc.ca/publications/Circulars/technical/circulars.asp>) for geometric design criteria for ski resort access roads.

#### 1520.02.02 Collector/Secondary

A road that provides for traffic movement between arterials and local streets with some direct access to adjacent property.

#### 1520.02.03 Local

A road primarily for access to residences, businesses, or other abutting property.

*NOTE: Local streets intended for commercial or industrial development are considered as collector roads.*

#### 1520.02.04 Cul-de-sac

A road termination providing a U-turn around area of constant radius.

#### 1520.02.05 Hammerhead

An arrangement to allow a vehicle to turn around at the end of a dead end road. It is shaped like a "T" intersection and allows the vehicle to turn 90 degrees in one direction, back up and then turn 90 degrees to return in the opposite direction from original travel.

### 1520.03 DRAWINGS

The developer shall submit metric road design drawings to the Ministry which include, but are not limited to, the following:

1. **Location Plan:** Scale 1:500 or 1:1000 showing horizontal alignment, lot lines, legal description of lots, proposed alpine ski village, extents of cut and fill, proposed rights-of-way (dedicated and statutory), signing, existing and proposed culvert locations, existing water courses and proposed drainage pattern.
2. **Profile:** Scale 1:1000 horizontal and 1:100 vertical, showing the existing ground line and proposed finished road grade.
3. **Laning Drawings:** Same scale as plan drawings, road markings, location and type of warning, regulatory, directional, and if necessary, special signs to be installed.
4. **Cross Sections:** when required by the Ministry Representatives.
5. **Typical Cross Sections:** as required

The developer will commence road construction only after the Ministry Representative has accepted the road design in writing, unless under subdivision process requiring Preliminary Layout Approval (PLA). In this circumstance, Ministry approval to commence road construction is not required.

MoT Section	1520	TAC Section	Not Applicable
-------------	------	-------------	----------------

**1520.04 ACCOMMODATING PEDESTRIANS AND CYCLISTS**

It is recognized by the nature of alpine ski village roads, that cyclists and pedestrians will use these roads for travel within the village.

On local roads, consideration should be given to include an additional 1.8 m of roadway width in order to accommodate pedestrians. No special accommodations are required for cyclists.

On collector roads, consideration should be given to include an additional 3.6 m of roadway width, in order to provide pedestrians with 1.8 m walking spaces on each side of the roadway. In developing 4-season resorts, consideration should be given to provide 4.3 m wide shared travel lanes in order to accommodate cyclists. Where forecasted cycling volumes are not high, or at winter only locations, no special accommodations are required for cyclists.

If a trail network is provided independent of the road network, and services an area, it may be considered in substitution to a sidewalk adjacent to the road, provided that it has been agreed to by the Project Team.

*NOTE: If a sidewalk is desired by the Developer, this should be discussed with the Project team. If the Project team decides that it is acceptable for a sidewalk to be constructed, maintenance and replacement of the sidewalk shall be solely the responsibility of the Developer and/or ski hill operator.*

**1520.05 SNOW STORAGE**

Snow clearing storage shall be addressed and accommodated on a site specific basis based on snow course data and/or snowfall data, and knowledge of snowfall history for the area.

Snow clearing storage area, typically provided by ditches, will be designed to provide storage for snow compacted to a density of 500 kilograms per cubic metre (50% water equivalent). Accumulated volumes of snow are to be determined using a maximum storage height of 2.0 metres, with a maximum slope angle of 1:1 on the road/shoulder edge.

Accommodation for snow storage must also be provided in consideration of the number of parking spaces and/or access to parking spaces provided for the development(s).

Where alternate snow storage area is provided (non adjacent to the road storage), sites will be considered for

approval in consideration of operational plowing capabilities.

Steps **I**, **II**, and **III**, shown below, outline the process for calculating snow storage requirements. A “Snow Storage Calculation” spreadsheet is available online to do these calculations at:

[http://www.th.gov.bc.ca/publications/eng\\_publications/geomet/TAC/TAC.htm](http://www.th.gov.bc.ca/publications/eng_publications/geomet/TAC/TAC.htm)

**I**

Snow accumulations for volume of snow storage requirements will be determined using either Method A or B. Wherever possible, calculations should be completed using Method A (based on snow course information).

*NOTE: The Canadian convention for new snowfall density is 100 kilograms per cubic metre.*

**Method (A)**

- Data provided from snow course readings from an on site location, or nearby, comparable data collection site, from readings taken on or near March 1<sup>st</sup>
- Average normal snow water equivalents will be used to calculate snow storage requirements
- Apply a 1:10 conversion rate for precipitation (Meteorological Standard), i.e. 1 mm water = 1 cm snowfall
- Convert to compacted snow volume @ a density of 500 kilograms per cubic metre. As the Canadian convention for new snowfall is 100 kilograms per cubic metre, the conversion ratio will be 5:1.

**Sample Calculation**

<ul style="list-style-type: none"> <li>○ Snow course @ March 1<sup>st</sup> identifies 600 mm average normal snow water equivalent</li> <li>○ Converted to snowfall amounts at 1:10 ratio, 600 mm of water = 600 cm of snow</li> <li>○ Converted to snowfall depth, 600 cm snow * (100 kg/m<sup>3</sup> / 500 kg/m<sup>3</sup>) = 1.2 metres of snow depth</li> </ul>
---

**OR**

MoT Section	1520	TAC Section	Not Applicable
-------------	------	-------------	----------------

**Method (B)**

- An average annual accumulated daily snowfall to March 1<sup>st</sup>
- Convert to volume @ a density of 500 kilograms per cubic metre

**Sample Calculation**

- Average annual accumulated snowfall to March 1<sup>st</sup> identified as 750 cm
- Converted to snowfall depth,  
750 cm snow \* (100 kg/m<sup>3</sup> / 500 kg/m<sup>3</sup>)  
= 1.5 metres of snow depth

**II**

Once the equivalent depth of snow is calculated from Methods A or B outlined above, the volume requirement for snow storage per lineal metre of road can be calculated.

**Sample Calculation**

- 1.2 metres of snow depth (calculated as per Method A above)
- Lane width to clear = 3.0 metres
- Volume of snow per lineal metre,  
1.2 m \* 3.0 m = 3.6 m<sup>3</sup>/m

Based on this calculated volume of snow per lineal metre, the developer must then provide the Ministry with a roadway cross section, which can accommodate this volume of snow. Cross sections may include ditches, dedicated snow storage aisles or other concepts, but must comply with the maximum storage height of 2.0 metres and maximum slope angle of 1:1.

**III**

Additional snow storage accommodation must be made for parking accesses by adding capacity to the above calculations.

**Sample Calculation***Given:*

- 1 access point of 2.4 metres width, plus an adjacent 3.0 metre lane width to clear
- 1.2 metre of snow depth (calculated as per Method A above)

*Calculations:*

- Volume of Snow Area = 2.4 m access width \* 3.0 m lane \* 1.2 m of snow depth = 8.64 m<sup>3</sup> of additional snow to accommodate

- This additional snow can be distributed in two ways:
  - a) Along the road/shoulder @ a minimum road length along the shoulder edge of 3.0 metres
  - b) Other option proposed by the developer; ditches, etc.

- It is recognized that accumulated, plowed snow compacts to a higher density than 500 kilograms per cubic metre, but individual average maximum snowfall events must be accommodated in the defined storage area, and are not considered in these calculations.
- The defined density requirement provides flexibility to manage most individual snowfall events. Road shoulders will provide additional capacity to accommodate some snow during the larger snowfall events.
- The maximum snowfall events will not be accommodated in these calculations. During these maximum snowfall events, the availability of road surface will be compromised, but they are expected to be infrequent and for relatively short periods of time.

Other options for snow storage calculations can be conducted, and will be considered based on individual submissions from the developer(s) (e.g. an analysis of average and maximum individual snowfall events, their frequency and interval, plus a calculation for settlement, compaction, etc.)

Alternate snow storage options will also be considered, in consideration of operational capabilities, parking designation, alternate snow storage locations, and operational considerations provided by the developer and/or the community or owners associations.

**1520.06 ON-STREET PARKING**

As the requirement for on-street parking has a significant effect on the finished top width and Right-of-Way required for roadways, the provisions for on-street parking facilities shall be discretionary, and should be determined within the relative context of the various land uses within the various ski resorts. Where on-street parking is to be included in the design, 2.4 metres shall be added to the street width

**Figure 1520.A** depicts the practice for including on-street parking facilities in the roadway design.

MoT Section	1520	TAC Section	Not Applicable
-------------	------	-------------	----------------

*NOTE: Elevated parking aisles and add-on parking nodes are not considered to be acceptable provisions for ski resort areas as these types of parking facilities cause a major hindrance on winter maintenance activities.*

- On-street parking shall only be considered after full and complete consultation by the Project team outlined in **1510.00** of this Guideline. Areas where parking is to be permitted should be carefully considered so as not to affect the safety of all other road users.
- It is MoT's preference to have no on-street parking as it significantly impairs snow removal operations, especially in these high alpine resort areas.
- Regardless as to whether on-street parking is allowed or not, consideration should be given to establishing a protocol at the local level regarding:
  - Notification and/or ticketing and/or towing of illegally parked vehicles
  - The administration of this activity
  - Location of a suitable on hill vehicle impound (if available)
- See below for some methods to accommodate on-street parking. Other methods may exist and be better suited for the resort in question.

#### **Proposed Methods for Accommodating On-Street Parking:**

- Developers and/or ski hill operators wishing to have on-street parking may want to consider strata type development options.
- Consider only allowing on-street parking on one side of the roadway, preferably on the up slope side.
- Use parking control signs to limit parking. Discussions should include maintenance contractors when determining when to restrict parking.

**Figure 1520.A On-Street Parking**

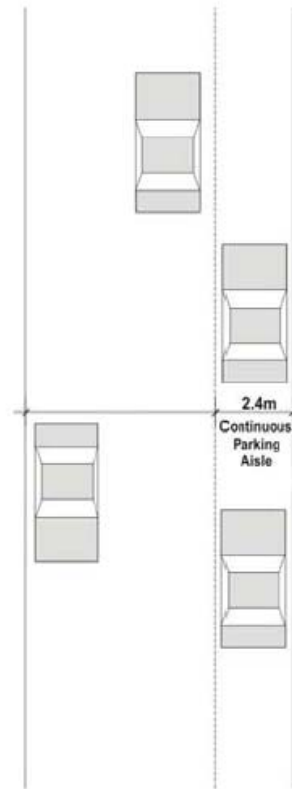

MoT Section	1520	TAC Section	Not Applicable
-------------	------	-------------	----------------

### 1520.07 ALIGNMENT

The developer shall complete all road designs within the design speed range of 30 km/h to 80 km/h, as determined by the road classification, or as requested by the Ministry Representative.

Vertical curves shall be standard parabolic curves.

For roads with design speeds of 70 km/h or more, the length of vertical curve (in metres) should not be less than the design speed (in km/h).

The developer shall demonstrate that every reasonable effort has been made to minimize the road grades. Short pitches\* of steeper grades (10% for collector roads and 12% for local roads) may be acceptable on tangent sections provided the overall grade is less than 8% for collector roads and 10% for local roads. Steeper grades are not acceptable on curved sections of roadway.

Minimum parameters for various design speeds shall be as shown in **Table 1520.B**.

\* Actual length of short pitches shall be at the discretion of the Project team.

**Table 1520.B – Design Parameters**

Road Classification	Local Roads		Local	Collector	Collector Roads		
	30	40			60	70	80
Speed (km/h)	30	40	50	50	60	70	80
Minimum Radius, (metres)*	20	45	80	80	130	200	280
Minimum stopping sight distance, (metres)	30	45	65	65	85	110	150
Minimum decision sight distance, (metres)	not applicable				95	125	155
K value crest, vertical curves, taillight height	2	4	7	7	13	23	36
K value sag, vertical curves, headlight control	4	7	12	12	18	25	32
K value sag, vertical curves, comfort control	2	4	6	6	9	12	16
Minimum overhead clearance (metres)**	4.5	4.5	4.5	4.5	4.5	4.5	4.5
Maximum desirable grade in percent*	10	10	10	8	8	8	8

Parameters based on  $E_{max}$ : 0.04 m/m

\*Avoid the combined use of maximum grade and minimum radius. Maximum grades are to be reduced by 1% for each 30 metres of radius below 150 metres.

\*\*Overhead clearance for structures

**Table 1520.C – Finished Top and Shoulder Widths**

	Basic Paved Width	Additional Paved Width for Parking (one side)	Additional Paved Shoulder Width to Accommodate Pedestrians – refer to 1520.04	Paved Width – 2 lanes shared by vehicles and cyclists
<b>Collector</b>	7.0 m	2.4 m	1.8 m (each side)	8.6 m (4.3 m per lane)
<b>Local</b>	6.0 m	2.4 m	0.9 m (each side)	n/a

#### 1520.07.01 Arterials/Primary

Refer to 1520.02.01.

#### 1520.07.02 Collectors (Network Roads)

##### Open Shoulder Collector/Secondary

- Cross Section: As per **Table 1520.C\***
- Gravel Shoulder: 1.0 metres
- See **Figure 1520.E**

##### Curb and Gutter Collector/Secondary (Curb and Gutter)

- Cross Section: As per **Table 1520.C\***
- Curb: 0.6 metres
- Gravel Shoulder: 0.5 metres behind curb
- See **Figure 1520.D**
- Refer to 1510.09.02.

\*Requirements for snow storage are in addition to basic cross section width. Refer to 1520.05.

MoT Section	1520	TAC Section	Not Applicable
-------------	------	-------------	----------------

Figure 1520.D Typical Two-Lane, Curb and Gutter, Alpine Ski Village Road

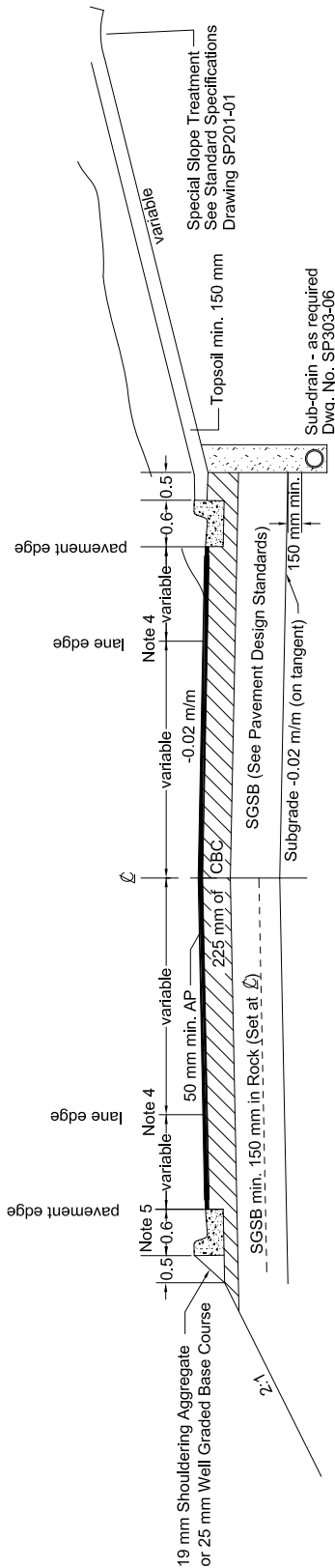

EARTH CUT SECTION

FILL SECTION

PAVEMENT DESIGN STANDARDS - See 1510.07.02

- These are typical gravel and asphalt depths to be used in the absence of geotechnical investigation.
- 50 mm A.P. to be constructed in accordance with the latest version of the B.C. MOT Standard Specifications for Highway Construction
- No S.G.S.B. is required in exceptional circumstances where the following criteria have been met:
  - Structural Design Criteria is satisfied and
  - Subgrade material consists of clean granular deposits that satisfy S.G.S.B. gradation and construction criteria (i.e. rutting criteria) in accordance with the latest version of the B.C. MoT Standard Specifications for Highway Construction - Section 202 "GRANULAR SURFACING, BASE AND SUB-BASES"
- MINIMUM 150 mm S.G.S.B. in Rock.
- All levelling materials applied directly to blasted rock cuts shall be of S.G.S.B. quality.
- THE FINAL S.G.S.B. THICKNESS MUST BE APPROVED BY THE REGIONAL GEOTECHNICAL AND MATERIALS ENGINEER.

Abbreviations:

- AP Asphalt Pavement
- CBC Crushed Base Course
- SGSB Select Granular Sub Base

Notes:

1. For accommodating cyclists, refer to Table 1520.C
2. For roadside barrier and drainage curb details, see Section 440
3. For utility installations, refer to Section 1520.09
4. For variable shoulder and top widths, refer to Table 1520.C
5. For typical curbs see SP582-01.01 to SP582-01.03 in the Standard Specifications
6. For rock ditches, see Section 440

MoT Section	1520	TAC Section	Not Applicable
-------------	------	-------------	----------------

Figure 1520.E Typical Two-Lane, Paved, Open Shoulder, Alpine Ski Village Road

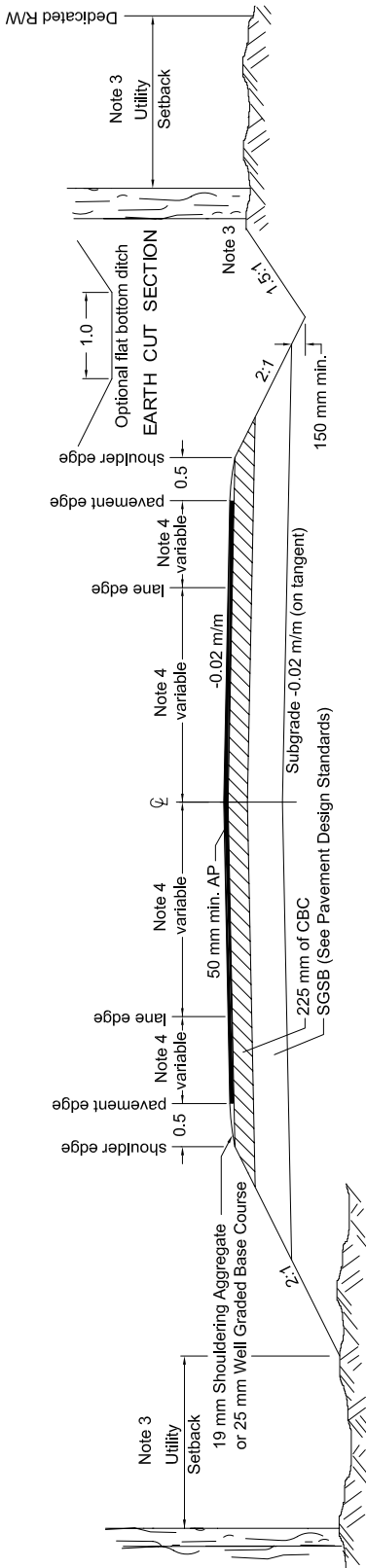

EARTH CUT SECTION

FILL SECTION

PAVEMENT DESIGN STANDARDS - See 1510.07.02

- These are typical gravel and asphalt depths to be used in the absence of geotechnical investigation.
- MINIMUM 150 mm S.G.S.B. on Coarse Grained Subgrades (Unified Soils Classification System - GW/GP/GM/GC/SW/SP/SM/SC) where groundwater does not pose a drainage problem and frost penetration does not affect the structure.
- MINIMUM 300 mm S.G.S.B. on Fine Grained Subgrades (Unified Soils Classification System - ML/CL/OL/MH/CH/OH).
- No S.G.S.B. is required in exceptional circumstances where the following criteria have been met:

Structural Design Criteria is satisfied and

Subgrade material consists of clean granular deposits that satisfy S.G.S.B. gradation and construction criteria (i.e. rutting criteria) in accordance with the latest version of the B.C. MoT Standard Specifications for Highway Construction - Section 202 "GRANULAR SURFACING, BASE AND SUB-BASES"

- MINIMUM 150 mm S.G.S.B. in Rock.
- All levelling materials applied directly to blasted rock cuts shall be of S.G.S.B. quality.
- THE FINAL S.G.S.B. THICKNESS MUST BE APPROVED BY THE REGIONAL GEOTECHNICAL AND MATERIALS ENGINEER.

Abbreviations:

- AP Asphalt Pavement
- CBC Crushed Base Course
- SGSB Select Granular Sub Base

Notes:

1. For accommodating cyclists, refer to Table 1520.C
2. For roadside barrier and drainage curb details, see Section 440
3. For Utility installations, refer to Section 1520.09
4. For variable shoulder and top widths, refer to Table 1520.C
5. For rock ditches, see Section 440

MoT Section	1520	TAC Section	Not Applicable
-------------	------	-------------	----------------

Figure 1520.F Typical Two-Lane, Gravel, Open Shoulder, Alpine Ski Village Road

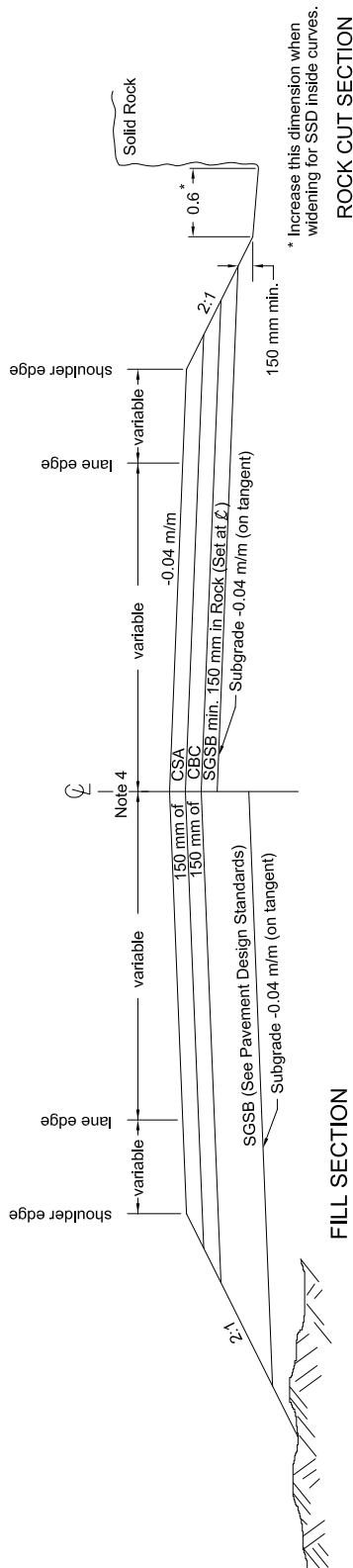

**PAVEMENT DESIGN STANDARDS - See 1510.07.02**

- These are typical gravel and asphalt depths to be used in the absence of geotechnical investigation.
- **MINIMUM** 150 mm S.G.S.B. on Coarse Grained Subgrades (Unified Soils Classification System - GW/GP/GM/GC/SW/SP/SM/SC) where groundwater does not pose a drainage problem and frost penetration does not affect the structure.
- **MINIMUM** 300 mm S.G.S.B. on Fine Grained Subgrades (Unified Soils Classified System - ML/CL/OL/MH/CH/OH).
- No S.G.S.B. is required in exceptional circumstances where the following criteria have been met:

Structural Design Criteria is satisfied  
and

Subgrade material consists of clean granular deposits that satisfy S.G.S.B. gradation and construction criteria (i.e. rutting criteria) in accordance with the latest version of the B.C. MoT Standard Specifications for Highway Construction - Section 202 "GRANULAR SURFACING, BASE AND SUB-BASES"

- **MINIMUM** 150 mm S.G.S.B. in Rock.
- All levelling materials applied directly to blasted rock cuts shall be of S.G.S.B. quality.
- **THE FINAL S.G.S.B. THICKNESS MUST BE APPROVED BY THE REGIONAL GEOTECHNICAL AND MATERIALS ENGINEER.**

**Notes:**

1. For accommodating cyclists, refer to Table 1520.C
2. For roadside barrier and drainage curb details, see Section 440
3. For Utility installations, refer to Section 1520.09
4. For variable shoulder and top widths, refer to Table 1520.C (substitute paved for gravel width)
5. For rock ditches, see Section 440

**Abbreviations:**

- CSA Crushed Surfacing Aggregate
- CBC Crushed Base Course
- SGSB Select Granular Sub Base

MoT Section	1520	TAC Section	Not Applicable
-------------	------	-------------	----------------

### 1520.07.03 Locals

#### Open Shoulder Local

- Cross section: As per **Table 1520.C\***
- Ditch inverts: Minimum 150 mm below subgrade \*\*
- Gravel shoulder: 0.5 metres
- See **Figures 1520.E & 1520.F**

#### Curb and Gutter Local

- Cross section: As per **Table 1520.C\***
- Curb: 0.6 metres
- Gravel shoulder: 0.5 metres behind curb
- See **Figure 1520.D**
- Refer to **1510.09.02**.

\*Requirements for snow storage are in addition to basic cross section width. Refer to **1520.05**.

\*\*Design flows should be considered when determining the minimum depth of ditch.

### 1520.07.04 Cul-de-sacs and Hammerheads

#### Grade:

Cul-de-sacs and hammerheads are only suitable in the alpine environment if the horizontal grade is 4% or less and the cross fall is 2% or less. Designs with a combined horizontal grade and cross fall exceeding an effective grade of 4% will not be accepted [ex.  $(0.04^2 + 0.02^2)^{0.5} = 0.0447$ , which is not acceptable] unless approved by the Regional Manager of Engineering as a design criteria exception.

#### Maximum Length:

Site specific conditions shall dictate the reasonableness of a proposed cul-de-sac or hammerhead and its length.

#### Parking:

Parking shall be restricted on cul-de-sacs and hammerheads in order to facilitate winter maintenance equipment.

#### Snow Storage:

Snow storage on cul-de-sacs and hammerheads must be specifically addressed. Refer to **1520.05**.

#### Cul-de-sacs

**Open Shoulder:** 15 metre radius finished top\*\*\*  
See **Figure 1520.G**

#### Collector:

14.5 metre radius paved top\*\*\*

0.5 metre gravel shoulder

#### Local:

14.0 metre radius paved top\*\*\*

1.0 metre gravel shoulder

**Curb and Gutter:** 15.2 metre radius finished top\*\*\*  
See **Figure 1520.H**

14.1 metre radius paved top\*\*\*

0.6 metre curb width

0.5 metre gravel shoulder

\*\*\*The above mentioned radii are nominal. The final finished size shall be determined by the Project team.

NOTE: Consideration will be given to using Offset Cul-de-sacs.

#### Hammerheads

See **Figures 1520.I & J**

#### Design Vehicles:

- Local: Heavy Single Unit (HSU) Truck
- Collector: WB-20 Tractor Semitrailer

NOTE: Designs that cannot accommodate the vehicles mentioned above will not be accepted. These design requirements are necessary in order to accommodate tandem snow plows without excessive maneuvering.

### 1520.07.05 Secondary Accesses and Mid Block Turn Arouds

Where possible, considerations should be given to the implementation of a secondary emergency vehicle access point along the cul-de-sac or hammerhead. These secondary accesses do not need to form part of the public roadway network and do not necessarily need to be paved.

#### Design Parameters – Secondary Accesses:

- Maximum grade: 15%
- Minimum width: 3.0 metres

Where possible and appropriate, developers should introduce midblock turnarounds to allow for design vehicle return movements on long stretches of single access roadway. If midblock turnarounds are required, they shall be designed to the parameters outlined for secondary accesses.

MoT Section	1520	TAC Section	Not Applicable
-------------	------	-------------	----------------

Figure 1520.G Collector/Local Open Shoulder Cul-de-sac

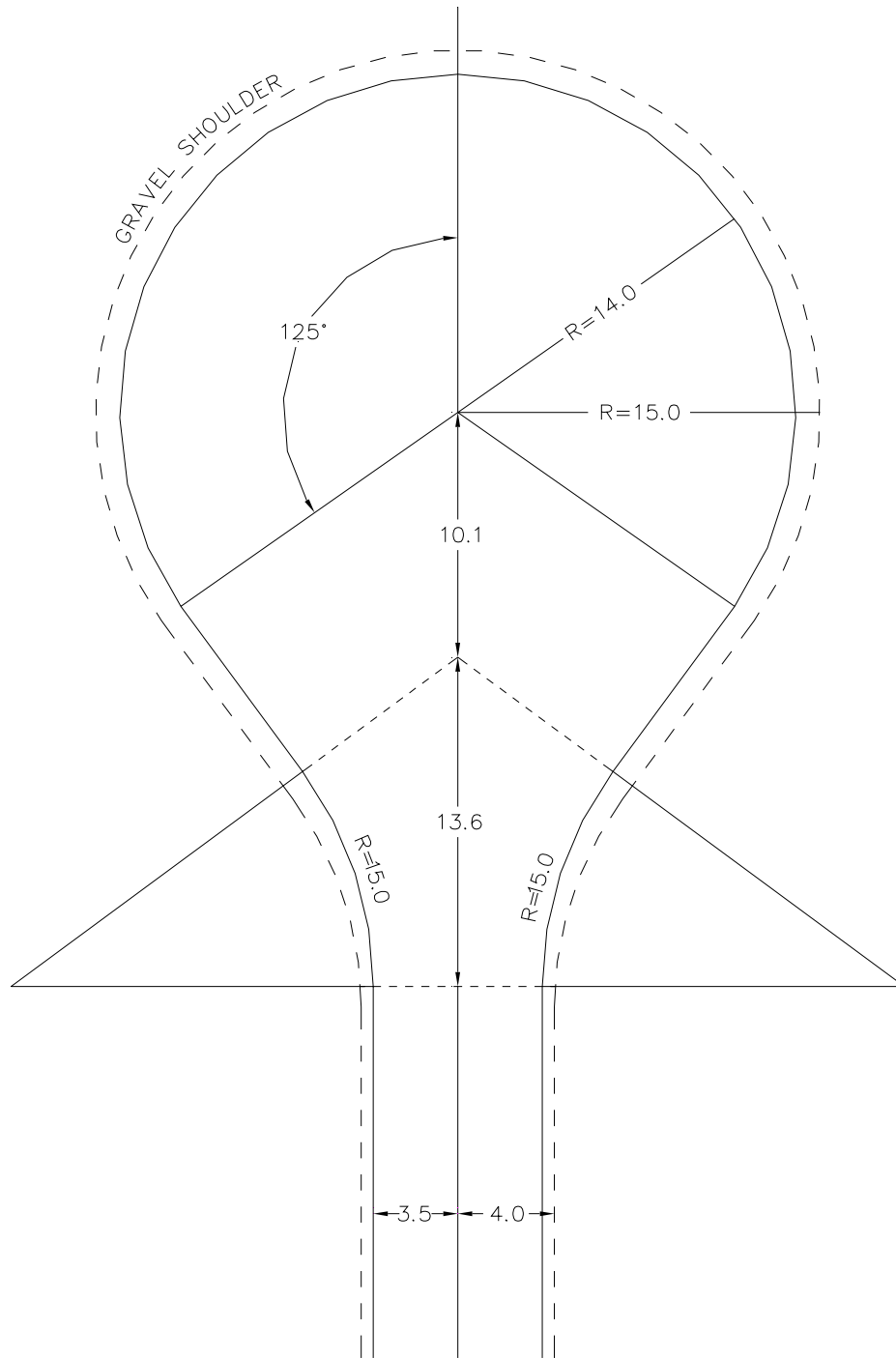

*NOTE: As noted in 1520.07.04, these distances are nominal. Site specific conditions will dictate the appropriateness of a design.*

MoT Section	1520	TAC Section	Not Applicable
-------------	------	-------------	----------------

Figure 1520.H Collector/Local Curb and Gutter Cul-de-sac

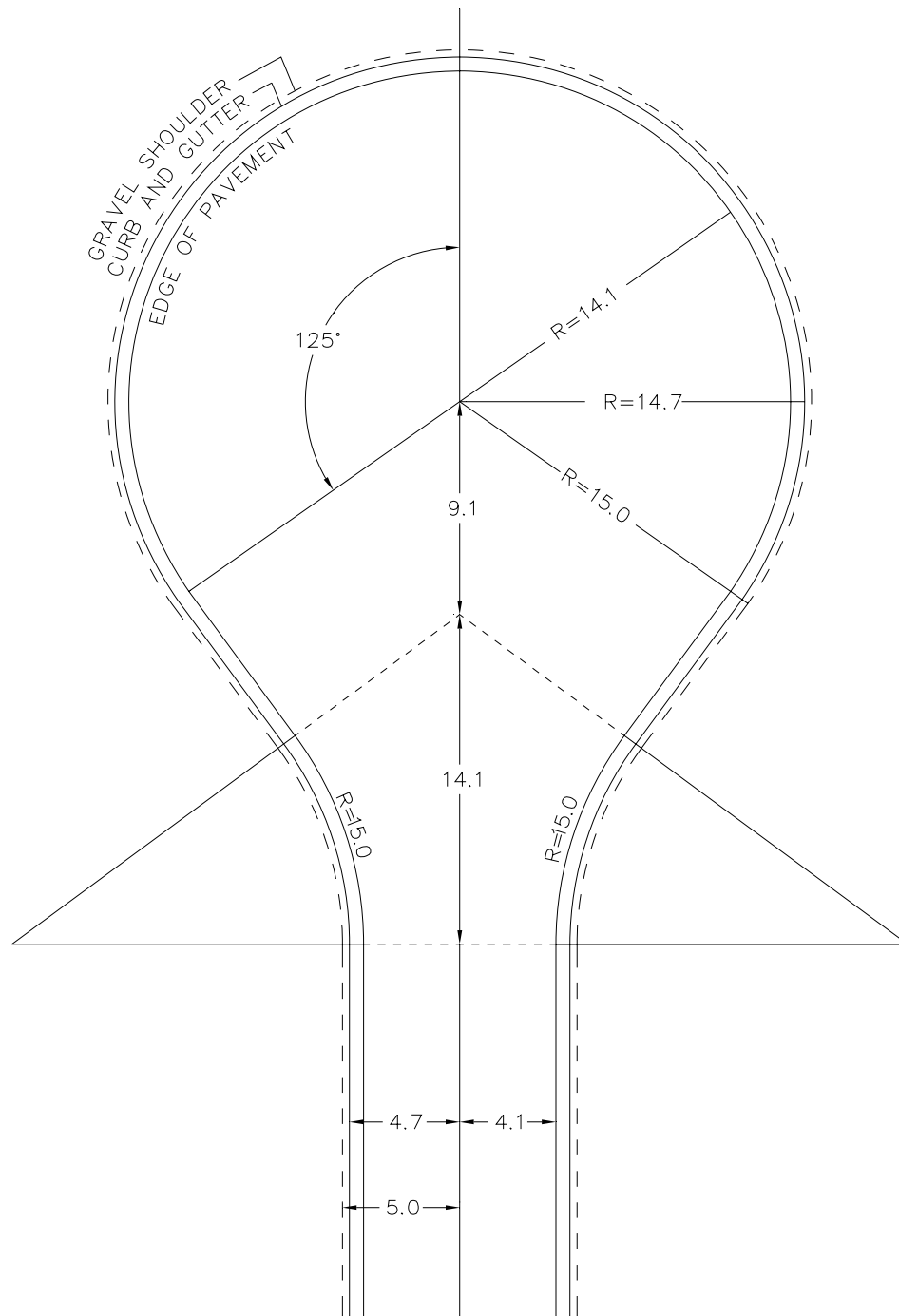

*NOTE: As noted in 1520.07.04, these distances are nominal. Site specific conditions will dictate the appropriateness of a design.*

MoT Section	1520	TAC Section	Not Applicable
-------------	------	-------------	----------------

Figure 1520.I Typical Hammerhead

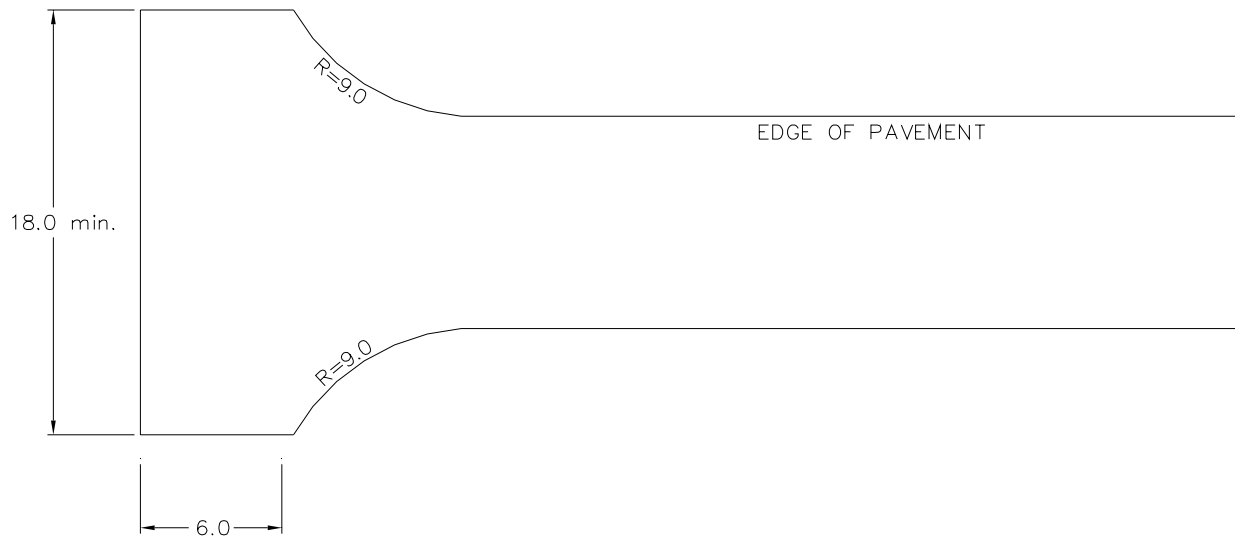
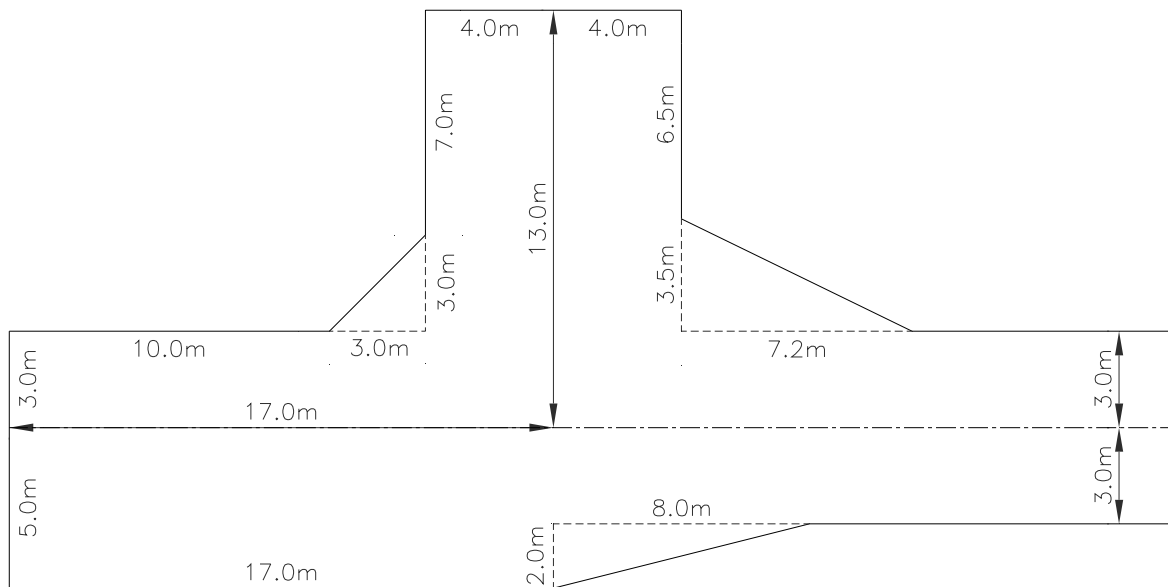

Figure 1520.J Modified Hammerhead



NOTE: As noted in 1520.07.04, these distances are nominal.  
Site specific conditions will dictate the appropriateness of a design.

MoT Section	1520	TAC Section	Not Applicable
-------------	------	-------------	----------------

### 1520.07.06 Cross Slopes

All roadways shall be constructed using a centerline crown and shall be graded and compacted with the following crossfall to ensure road drainage:

- Normal cross slopes shall be 2% for paved roads and 4% for gravel roads

### 1520.07.07 Superelevation

Superelevation is generally not applied on local alpine ski village roads or cul-de-sacs.

Rural roads of a continuous nature that provide access to an alpine ski village would be better classified as Low-Volume roads and should be superelevated accordingly. Refer to Chapter 500 Low-Volume Roads.

When the decision has been made to superelevate curves, a maximum rate of 0.04 m/m shall be used for local urban street systems. This is appropriate for design speeds up to 70 km/h and where surface icing and interrupted traffic flow are expected. Superelevation rates of 0.04 m/m and 0.06 m/m are applicable for design of new urban streets in the upper range of the classification system where uninterrupted flow is expected and where little or no physical constraints exist.

## 1520.08 INTERSECTIONS/ACCESSES

### 1520.08.01 General

Intersections shall be as near as possible to right angles. The minimum skew angle of the intersection shall be 70° and the maximum skew angle shall be 110°. If the through road grade is steeper than 8%, the intersection angle shall desirably be between 80° and 100°.

### 1520.08.02 Intersection Alternatives

Alternate intersection treatments, such as roundabouts, may be accommodated on a project by project basis, as per the discretion of the Ministry Representative.

### 1520.09 UTILITY SETBACK

Utility poles should be a maximum of 2 metres from the property boundary or a minimum 2 metres beyond the toe of the fill, whichever gives the greater offset from the road. See **Figure 1510.A**.

### Open Shoulder Sections

In open shoulder sections, the underground utilities can be located within the Dedicated Right-of-Way with approval from the Ministry Representative, based on the permit that has been issued, as follows:

Deep Utilities (water, sanitary and storm):

- Buried infrastructure: subject to location specified in permit
- Flush service accesses\*: subject to location specified in permit
- Above ground appurtenances: 1.5 m behind center of ditch

Shallow Utilities (hydro, telephone, TV and gas):

- Buried infrastructure, flush service accesses and above ground appurtenances: 1.5 m behind center of ditch

### Curb and Gutter Sections

In curb and gutter sections, the underground utilities can be located within the Dedicated Right-of-Way with approval from the Ministry Representative, based on the permit that has been issued, as follows:

Deep Utilities:

- Buried infrastructure: subject to location specified in permit
- Flush service accesses\*\*: subject to location specified in permit
- Above ground appurtenances, including protective structures (e.g. bollards): 2.0 m behind curb

Shallow Utilities:

- Buried infrastructure: 0.5 m behind curb
- Flush service accesses\*\*: 0.5 m behind curb
- Above ground appurtenances, including protective structures (e.g. bollards): 2.0 m behind curb

*\*No flush service access permitted within ditch.*

*\*\*Flush service accesses within 1.5 m of curb are required to meet full H-20 design loading.*

### Comments and Considerations:

- Installation of utilities in ditches should be avoided wherever possible.
- Dedicated utility corridors should be considered wherever possible.
- Utilities should be looked at in the planning stages to prevent having to move them in the future due to road widening or ditching.

MoT Section	1520	TAC Section	Not Applicable
-------------	------	-------------	----------------

### 1520.10 DRIVEWAYS

1. Driveway location, spacing and approval shall be at the discretion of the Ministry Representative. Where zoning does not apply, the developer must show that construction of an adequate access is possible and sufficient off-street parking for 2 vehicles is obtainable.
2. The first 5 metres (measured from the ditch centerline or back of curb) of all residential driveways shall be constructed at or near a right angle (70° to 110°) to the road.
3. All open shoulder driveways with a level or rising grade are to be constructed with a "valley" or "swale" over the ditch line to ensure surface water enters the ditch and does not enter the road. See **Figure 1520.K**.
4. Driveway grades shall not exceed 2% for 2 m from the ditch centerline or 2% for 3 m from the back of the curb with a maximum of 8% within the Right-of-Way.
5. Driveway radius and widths:
  - Residential – 6 metre radius and minimum 6 metre width at the property line
  - Commercial – 9 metre radius and minimum 9 metre width at the property line
6. All lots with cuts or fills of heights greater than 1.8 metres shall have engineered drawings when requested by the Ministry Representative.
7. Consideration should be given to driveway densities along local roads as high driveway densities result in insufficient space available for snow storage. Refer to **1520.05**.

MoT Section	1520	TAC Section	Not Applicable
-------------	------	-------------	----------------

**Figure 1520.K Culvert Installation**

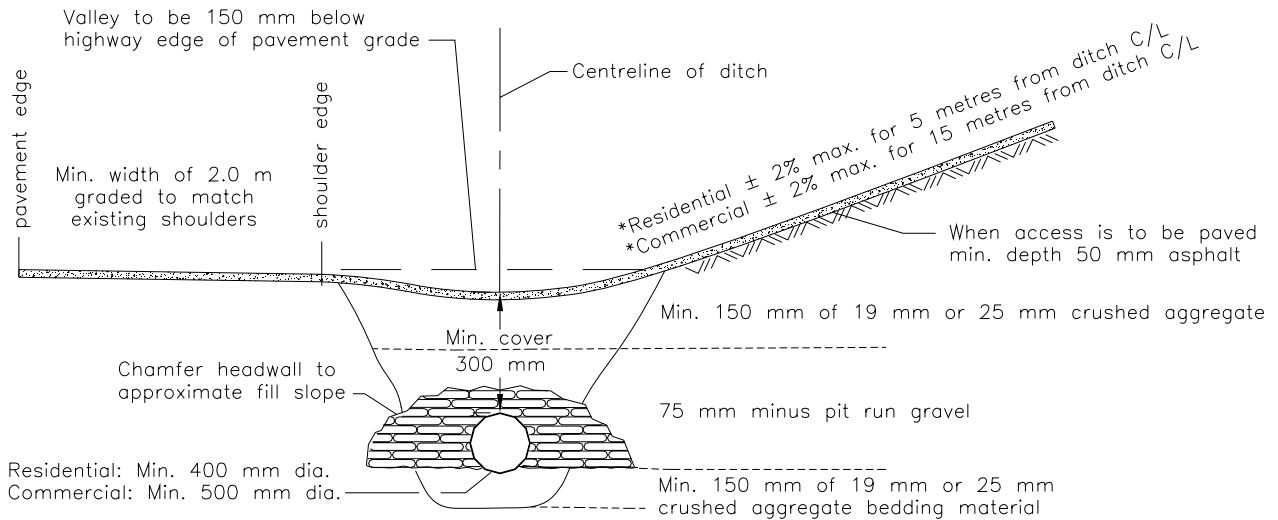

\*Note: Curb and gutter profile, 5 metres or 15 metres measured from back of curb

**NOTE:**

- Refer to BC Supplement to TAC Geometric Design Guide for comprehensive bedding and backfill details.
- Minimum pipe size may be increased at the discretion of the Ministry Representative.
- Minimum cover shall dictate invert elevation.
- See Notes under **Figure 1520.D**.

**Figure 1520.L Driveway Cross Section**

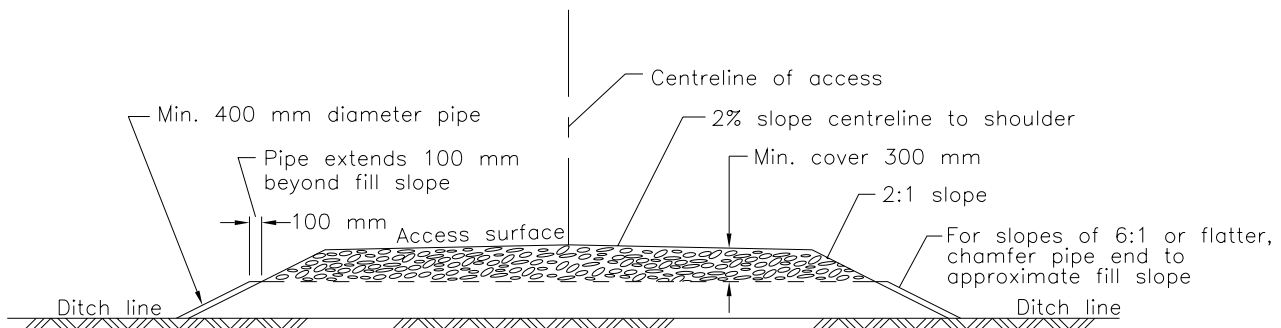

Driveway Culvert Installation: See **Figures 1520.K & 1520.M**

Residential Driveways: All driveway culverts shall be a minimum 400 mm diameter but may be increased at the discretion of the Ministry Representative.

Commercial Driveways: Cross and side culverts require a 500 mm minimum diameter.

MoT Section	1520	TAC Section	Not Applicable
-------------	------	-------------	----------------

**Figure 1520.M Driveway and Culvert Installation Layout**

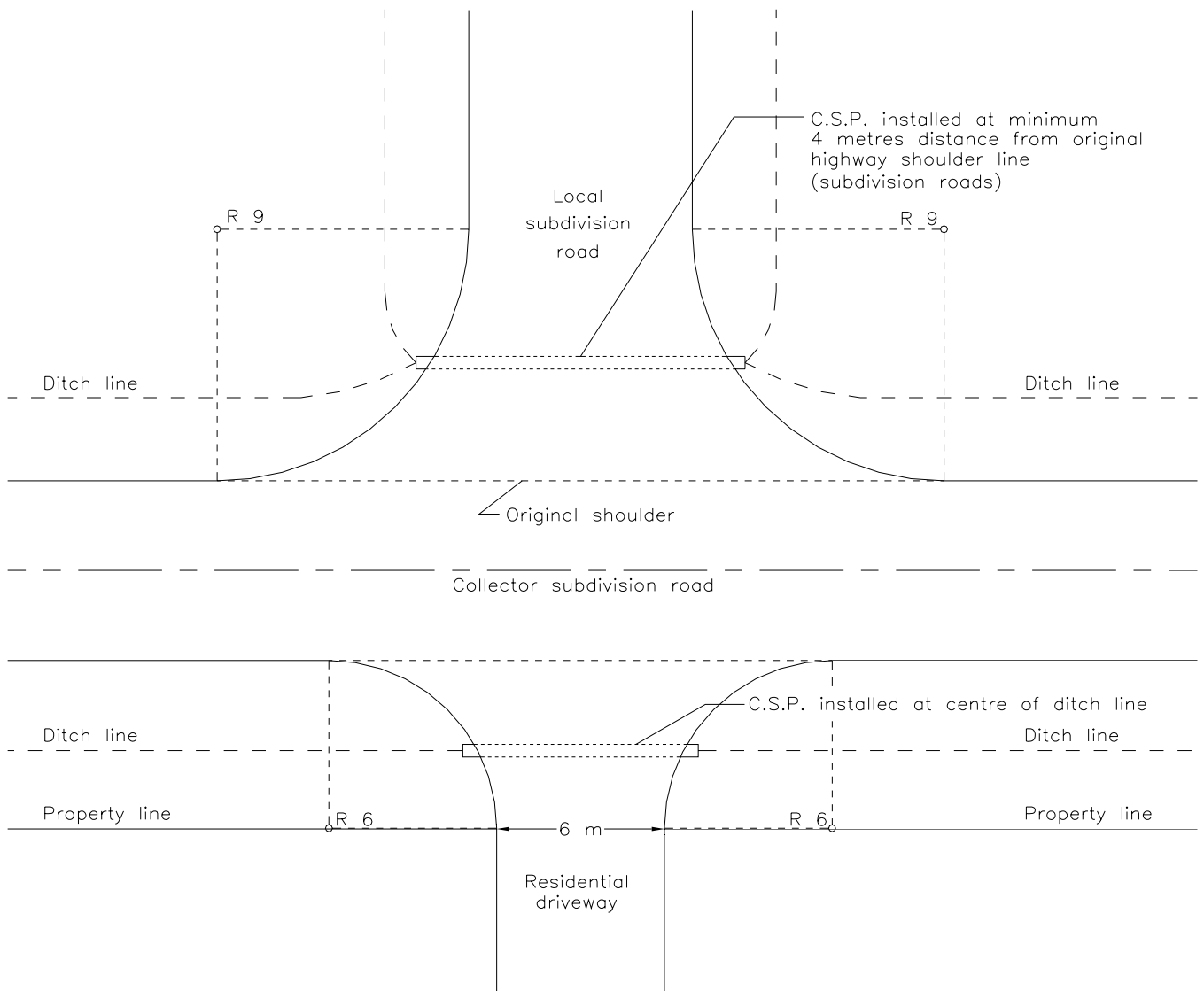

*Residential Driveway:*  
 Minimum 6 metre width at property line

*Commercial Driveway:*  
 Minimum 9 metre width at property line

*Turning Radius:*  
 Residential – 6 metres  
 Commercial – 9 metres

MoT Section	1520	TAC Section	Not Applicable
-------------	------	-------------	----------------

### 1520.11 BRIDGES

All bridges must be designed to Ministry bridge design standards by a Professional Engineer who is registered in British Columbia and is experienced in bridge design.

The designs for bridges and overpasses must be reviewed by and accepted by the Regional Bridge Engineer. The Professional Engineer shall certify that the completed structure has been constructed to Ministry standards.

#### 1520.11.01 Skier Overpass

Construction of a skier overpass requires a permit from the Ministry to pass over the Right-of-Way.

All skier overpasses must be designed by a Professional Engineer who is registered in British Columbia and is experienced in bridge design. Designs do not have to conform to Ministry bridge design standards but if a public hazard exists, the Ministry can request that the problem be rectified to ensure public safety.

Ownership and maintenance of a skier overpass shall be solely the responsibility of the ski hill operator.

#### Ski Lifts and Gondolas

As with skier overpasses, ski lifts and gondolas require a permit from the Ministry to construct over the Right-of-Way.

#### 1520.11.02 Skier Underpass

The review and acceptance of the skier underpass by the Regional Bridge Engineer only pertains to the structural aspect of the design. This acceptance **does not** constitute acceptance for any geotechnical, safety, or any other issues. The developer should have a risk management plan, with inspection guidelines, in place to ensure the overall safety of all users (drivers and skiers).

For bridge design approval, the Ministry asks that the developer provide a risk identification and analysis to ensure the final bridge design provides safe passage to all users.

Risk considerations may relate to:

1. Maintenance/Design
  - a. Ability of maintenance crews to adequately maintain bridge to provide safe passage to skiers
  - b. Skiers potentially getting hit by materials falling from bridge causing injury or loss of control. Typical materials would include:
    - i. Winter abrasives,
    - ii. Salt,
    - iii. Plowed snow, and/or
    - iv. Ice chunks from melting snow
2. Skiers
  - a. Skiers running into the bridge abutment walls
  - b. Mountain Bikers running into bridge abutment walls in the off-season
  - c. Inadequate grooming of ski-run within the Ministry's Right-of-Way resulting in safety issues for skiers

### 1520.12 SIGNING

Roads shall be appropriately signed as per the Manual of Standard Traffic Signs and Pavement Markings.

### 1520.13 SPEED

All unregulated/unposted roads in unorganized territory in British Columbia are limited to a maximum speed of 80 km/h (Motor Vehicle Act 151.1), therefore all roads designed at less than 80 km/h shall be posted accordingly.

### 1520.14 OVERHEAD CLEARANCE

Minimum overhead clearance for structures: 4.5 metres

Due to the allowance for lower overhead clearance in alpine ski villages than expected on the British Columbia primary highway network, developers are required to post signs informing drivers of the lower available overhead clearance heights. These signs must be posted at a reasonable distance prior to entering the alpine ski village, as directed by the Ministry Representative.

This reduced clearance is only acceptable in alpine areas. Developers should be aware of the impacts that the reduced clearance may have on accessibility to the area.

MoT Section	1520		TAC Section	Not Applicable
-------------	------	--	-------------	----------------

**This page is intentionally  
left blank**