

## **Appendix 400.1**

### **Traffic Engineering Checklist - How to Complete**

**(Refer to Template Section for  
Word Format Document)**

# **Traffic Engineering Checksheet**

## **How to Complete the Form**

**June 2003**

**Version 3**

**Maintained by:**

**South Coast Region  
Ministry of Transportation  
7818 6<sup>th</sup> Street Burnaby, B.C. V3N 4N8**

<b>Table of Contents</b>	<b>Page</b>
<b>A. How to Complete the form</b>	<b>1</b>
<b>B. Summary of Requirements</b>	<b>9</b>
<b>Appendix A – Blank Traffic Engineering Checklist</b>	<b>11</b>
<b>Appendix B – Sample Traffic Engineering Checklist</b>	<b>15</b>

## A. How to Complete the Form

This document should be used as a guideline for completing a Traffic Engineering Checklist (TEC) being submitted to the Ministry. Only qualified professional engineers familiar with the Ministry Traffic and Electrical Engineering Standards manual, associated Technical Bulletins, the Ministry Manual of Standard Traffic Signs & Pavement Markings, TAC geometric Design Guidelines for Canadian Roads and the B.C. Supplement to the TAC Guidelines should complete this form. Current technical Bulletins can be viewed at the following website:

[http://www.th.gov.bc.ca/BCHighways/operations/hwyeng/TE\\_Bulletins/TE\\_bulletins.htm](http://www.th.gov.bc.ca/BCHighways/operations/hwyeng/TE_Bulletins/TE_bulletins.htm)

All new traffic signals or modifications to existing traffic signals including simple geometric improvements, paint marking modifications or signing changes at signals must be approved by the Ministry via a properly completed Traffic Engineering Checklist. TEC's submitted by consultants must be signed off by a Ministry Regional Traffic Engineer prior to commencing electrical design for new or modification to an existing signal. Failure to obtain approval prior to commencing design may result in additional work to the designer due to Regional Traffic Engineer design scope or detail changes; any additional costs for changes shall be borne by the design consultant.

The following sections correlate directly with the various sections of the Traffic Engineering Checklist. A sample completed TEC is included as an appendix to this document. The references in this document refer to the Traffic Engineering Checklist dated July 2003 (Version 3).

### 1) Location

- a Enter the location of the traffic signal in the format **MAJOR STREET NAME @ MINOR STREET NAME, CITY**. If the location is an on or off ramp, identify the intersection using the ramp direction and designation (e.g. *Route 1 E/B off-ramp @ Lickman Road, Chilliwack*). Location information should be included on all of the TEC sheets and any attached additional information.
- b **Project Number** - Indicate the project number that is being used for this project if known.
- c **MoT Intersection SiteCode** – if this information has already been provided, enter it here. If not, contact the Regional Traffic Engineer to obtain this information. Sitecodes are unique identifiers for intersections assigned by the Ministry.

## 2) Scope

- a Identify the scope of the work being done at this location (i.e. new traffic signal, adding emergency preemption to an existing signal, adding an eastbound left turn to an existing signal, modifying the north/south phasing to split phase, etc.). Be specific, comprehensive and clear as to what is happening.

## 3) Civil Design Scope

- a **Comments based on** – indicate what drawings are being used to complete the rest of the TEC. If you are using an existing electrical drawing indicate what drawing and revision level you are using. If you are using a new or existing civil design drawing indicate the drawing number including revision and/or dates as necessary. You must **attach** a copy of the drawing you are using for this TEC. As a minimum the drawing must clearly show the proposed geometrics for the signal installation/ modification in compliance with the TAC Geometric Design Guidelines for Canadian Roads and the B.C. Supplement to the TAC Guidelines. A qualified civil design engineer must sign the geometric drawing.
- b **Crosswalk revisions required** – indicate whether any crosswalks need to be modified or installed as part of the signal installation. You may either mark-up the drawing or clearly describe in the field provided.
- c **Stop Line revisions required** – indicate whether any stop bars need to be modified or installed as part of the signal installation. You may either mark-up the drawing or clearly describe in the field provided.
- d **Lane Markings revisions required** – indicate whether any lane markings need to be modified or installed as part of the signal installation. You may either mark-up the drawing or clearly describe in the field provided. You should pay particular attention to guidelines, continuity lines and left turn arrows.
- e **Turning Path Revision Required** – by checking yes in this box you indicate that you have verified all of the turning movement templates for the design vehicle for this intersection. You should indicate what design vehicle was used. You must pay particular attention to opposing left turn movements that have overlapping templates as this may require the use of split phasing or lagging left turn phasing with geometric constraint. If constraints exist, they must be listed in the description field.
- f **Civil design prepared by** – the engineer preparing the lane marking information must print their name, sign and date the form.

#### 4) Traffic Design Scope

- a **Road Classification** – Identify the classification of the roadway segment. This information will be used for street lighting warrants and illumination levels (refer to Section 300 of the Traffic and Electrical Engineering Manual).
- b **Signing Modifications** – you must **ATTACH** a drawing showing the location of all existing signing for this signal installation.
- c **Guide Sign Modifications required** – identify any guide signs that need to be added or modified for this project. You may either describe the guide sign and identify its location in the field provided, or add it to the signing drawing above. Modifications to the existing drawings must be completed by a professional engineer qualified in signing design. The Ministry Manual of Standard Traffic Signs & Pavement Markings shall be used for all signing requirements.
- d **Lane Use Sign Modifications required** – identify any lane use signs that need to be added or modified for this project. You may either describe the lane use sign and identify its location in the field provided, or add it to the signing drawing above. Modifications to the existing signing must be completed by a professional engineer qualified in signing design. The Ministry Manual of Standard Traffic Signs & Pavement Markings shall be used for signing requirements.
- e **Turn Restrictions Sign Modifications required** – identify any turn restriction signs that need to be added or modified for this project. You may either describe the turn restriction sign and identify its location in the field provided, or add it to the signing drawing above. Modifications to the existing signing must be completed by a professional engineer qualified in signing design. The Ministry Manual of Standard Traffic Signs & Pavement Markings shall be used for signing requirements. Particular attention to turn restrictions shall be made at signals at on or off ramps.
- f **Other Sign Modifications required** – identify any signs that need to be added or modified for this project. You may either describe the sign and identify its location in the field provided, or add it to the signing drawing above. Modifications to the existing signing must be completed by a professional engineer qualified in signing design. The Ministry Manual of Standard Traffic Signs & Pavement Markings shall be used for signing requirements. Particular attention shall be made to the use of yield, restricted entry and hazard markers.
- g **Advance Warning Signs** – complete the table showing the posted speed and grade of each approach including identification of road names and directions. Identify whether the signal requires advance warning signs as

per the warrants in the Traffic and Electrical Engineering Manual. Note those advance warning signs that are required in the field provided.

- h **Island Flashers** – identify any island flashers that are required based on the warrants (including current technical bulletins)
- i **Emergency preemption** – contact the local municipality and identify whether they wish to have emergency vehicle preemption included in the design. Emergency preemption costs are 100% the responsibility of the municipality. If emergency preemption is not required by the municipality – indicate “Municipality does not want at this time”; a letter should be included in the design folder indicating who was contacted at the municipality. If preemption is required, identify the type of preemption required and the directions of preemption requested as well as whether the municipality wants to use indicating lights. Refer to the Traffic and Electrical Engineering manual for more details on emergency preemption options.
- j **Rail preemption** – indicate whether railway preemption will be required and what leg of the intersection. Signals within 200 meters of a railway crossing should be considered for interconnection and railway preemption. Identify whether blankout signs are required for the left turn and right turn movements; blankout signs are typically required for permissive left turns. Contact the Ministry Rail/Navigable Waters Coordinator for contacts with rail authorities.
- k **Pedestrian Accommodation** – indicate what pedestrian accommodations are required at the traffic signal. Accommodation could be audible signal heads, modified pedestrian heads, special pushbuttons or signage, etc. As a minimum, contact the municipality and identify whether audible signals will be required at this intersection; the municipality typically coordinates the requirement of audible signal heads with the Canadian National Institute of the Blind. If no audibles are required, indicate that “Municipality does not want at this time” in the field and ensure appropriate documentation is included in the design folder identifying who the contact was at the municipality.
- l **Cyclist Accommodation** – refer to Interim Technical Bulletin on Cyclist Actuation at Traffic Signals. Indicate how cyclists are to be accommodated at the signal (bicycle stencil, separate cyclists pushbutton, bicycle loop, etc.). Cyclists must be accommodated per the Technical Bulletin.
- m **Transit/HOV Accommodation** – Indicate if there are any transit or HOV-specific requirements on this project such as special pavement markings, signal phasing, actuation devices, etc.

- n **Special Detector Requirements** – indicate any special detector requirements. Particular attention should be made with off-ramps on freeways. Queue loops that would facilitate clearing the ramp must be included; the designer must determine the location of the queue loops to enable no queuing on the freeway through lanes; documentation on calculations must be included in the design folder. Advance loops shall be included with all traffic signals that have advance warning signs.
- o **Future Requirements** – identify any particular requirements that would be less expensive to consider now than in the future. Particular attention should be made to the need for future left turn arrows; pulling additional wiring now is cheaper than in the future, and the controller can be pre-configured to accommodate these movements.
- p **Controller Requirements** – Identify whether the signal will use the existing controller cabinet or require a new one, and whether the controller cabinet will be a 4 phase M cabinet or 8 phase S cabinet. Contact the Regional Traffic Engineer to confirm controller requirements. It is important to consider future requirements when deciding an M or S cabinet. Particular attention should be made to the current status of existing cabinets – older P and M-shelf mount cabinets are not upgradeable and must be replaced. Contact the Manager, Electrical Services for information on existing equipment.
- q **Other Items or Comments** – identify any other issues that need to be considered for the traffic signal design and which the Regional Traffic Engineer or Electrical designer requires to approve/complete the design.

## 5) Signal Phasing

- a **ATTACH a preliminary timing sheet** - you must attach a preliminary timing sheet conforming to Ministry standards; only phase assignments, advance warning times and resting/recall phases need to be shown on the preliminary timing sheet. You must include a copy of Synchro reports to confirm the phasing chosen. A final timing sheet must be submitted once the electrical design is complete. Note that you must submit electronic versions of the traffic signal timing sheet and complete Synchro analysis on a CD. Refer to the Traffic and Electrical Engineering Design Manual Section 200 for further details.
- b **Signal Phasing Layout** - complete the Signal Phasing Layout per the attached example and the Traffic and Electrical Engineering Standards manual. The Signal Phasing Layout shows all of the available phase movements applicable to the traffic signal operation. The north arrow and street names must be included on the diagram.

- c **Signal Phasing Sequencing** - based on the above Signal Phasing Layout, identify all combinations of phases that can be on at the same time in sequential order. If phasing is complex and cannot easily be displayed, include a separate document outlining in detail how the signal is to operate relative to the Signal Phasing Layout. You must include all transit/HOV, emergency and railway preemption and clearance phases in the sequencing boxes.
- d **Traffic Engineering Prepared by** - the engineer preparing the traffic engineering information must print their name, sign and date the form. The engineer must be a registered professional engineer qualified in traffic signal design.

**6) MoT Traffic Engineering Approval**

- a The TEC must be submitted to the Regional Traffic Engineer for approval. The RTE shall either tick the “recommend to proceed” field, or tick the “Changes required” field and list the identified deficiencies. The form will then be signed and returned to the originator. Forms that require changes must be modified by the originator and resubmitted for approval prior to proceeding with the electrical design.

## **B) Summary of Requirements**

Prior to submitting the Traffic Engineering Checklist to the Ministry for approval, the consultant shall ensure that:

- 1) These guidelines have been followed in their entirety
- 2) A signed geometric plan showing proposed civil improvements is attached
- 3) A plan showing all existing signing is attached
- 4) A preliminary timing sheet is attached
- 5) An electronic copy of the Synchro file is attached

The Ministry Regional Traffic Engineer may reject all submissions not complying with the above requirements.

# Appendix A

## Blank Traffic Engineering Checklist June 2003 Version

# Traffic Engineering Checklist

**Location:** \_\_\_\_\_  
(route , cross street and city)

**Project Number:** \_\_\_\_\_ **MoT Intersection SiteCode:** \_\_\_\_\_

## Instructions:

- This checklist must be completed for all new or modifications to existing traffic signals.
- Attach supplementary pages if the space provided is not adequate.
- Page 3 must be signed by a MoT Traffic Engineer for completion.

## Scope (Briefly describe the scope of work)

---

---

---

---

---

---

## Civil Design Scope

Comments based on:  civil design drawings # \_\_\_\_\_  
and/or:  existing electrical drawings TE # \_\_\_\_\_

Crosswalk revisions required?

No  yes  \_\_\_\_\_  
(description or attach drawing)

Stop lines revisions required?

No  yes  \_\_\_\_\_  
(description or attach drawing)

Lane marking revisions required?

No  yes  \_\_\_\_\_  
(description or attach drawing)

Turning path revisions required?

No  yes  \_\_\_\_\_  
(description or attach drawing)

Civil Design prepared by:

\_\_\_\_\_  
(Engineer's signature) (print name) (date)

## Traffic Design Scope

Road classification: \_\_\_\_\_  
(rural arterial, urban arterial, etc.)

Signing modifications required? (if yes describe in detail or attach drawing)

Guide Sign modifications required?

No  yes  \_\_\_\_\_  
(size & location – stn.#)

Lane Use sign modifications required?

No  yes  \_\_\_\_\_  
(location(s) – stn.#)

Turn restrictions sign modifications required?

No  yes  \_\_\_\_\_  
(type & location – stn.#)

Other sign modifications required?

No  yes  \_\_\_\_\_  
(description & location – stn.#)

# Traffic Engineering Checklist

**Location:** \_\_\_\_\_  
(route and cross street)

## Traffic Design Scope (continued)

Special features revisions required? *(describe in detail if yes)*

Advance warning signs *(complete table below)?*

No  yes  \_\_\_\_\_  
(Which approaches?)

Approach	Speed km/h	Grade %	Approach	Speed km/h	Grade %
North			East		
South			West		
Road name: _____			Road name: _____		

Island flashers:

No  yes  \_\_\_\_\_  
(Note those which exceed standards.)

Emergency preemption:

No  yes  \_\_\_\_\_  
(Type – hardwire, audible, radio, strobe)

Indication lights: no  yes  \_\_\_\_\_  
(Type and location)

Rail preemption: *(which approaches?)*

No  yes  \_\_\_\_\_

Blank-out display: no  yes  \_\_\_\_\_  
(Type and approach)

Audible signals:

No  yes  \_\_\_\_\_  
(Location – intersection leg)

Cyclist Actuation *(must accommodate for new installations):*

No  yes  \_\_\_\_\_  
(Describe – loops, stencils, pushbuttons):

Special detector requirements:

No  yes  \_\_\_\_\_  
(Advance loops, queue loops, etc.)

Future requirements *(within 5 years):*

No  yes  \_\_\_\_\_  
(e.g. advance arrows, different phasing, etc.)

Controller requirements:

New  or Use existing  M cabinet  or S cabinet  \_\_\_\_\_

Other items or comments: (Attach supplementary pages if the space provided is not adequate.)

---

---

---

---

---

---

---

---

---

---

**ATTACH a preliminary timing sheet showing the following:**      • phase assignments

- advance warning times
- resting/recall phases

# Traffic Engineering Checklist

**Location:** \_\_\_\_\_  
(route and cross street)

## Traffic Design Scope (continued)

Site diagram (show all movements and north arrow).

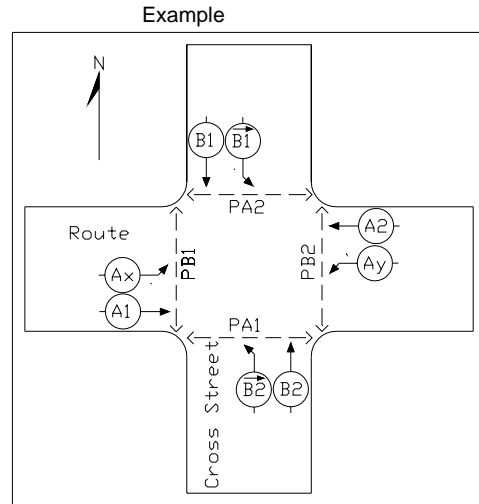

Signal phasing diagram (relative to site diagram above).

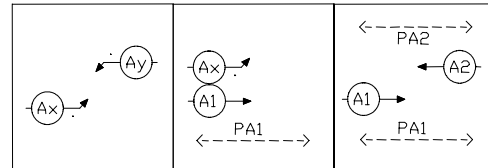
Show all combinations of vehicle and pedestrian movements in sequence.

Show emergency, railway, bus and other preemption sequences.

Identify clearance and preemption phases.

Traffic engineering prepared by:

\_\_\_\_\_  
(Engineer's signature) (print name) (date)

## MoT Traffic Engineering Approval (Must be completed for a checklist prepared by a consultant)

- Recommend to proceed.
- Changes required (consultant must resubmit):**

---



---



---



---

# Appendix B

## Sample Traffic Engineering Checklist

# Traffic Engineering Checklist

1. Location: Hwy 25 @ Cross Street, District of North Peace  
(route, cross street and city)

Project Number: 61118-0003 MoT Intersection SiteCode: 600017

## Instructions:

- This checklist must be completed for all new or modifications to existing traffic signals.
- Attach supplementary pages if the space provided is not adequate.
- Page 3 must be signed by a MoT Traffic Engineer for completion.

## 2. Scope (Briefly describe the scope of work)

- Modify existing traffic signal – Add NB left turn arrow  
- Modify traffic islands – Add right turn lanes in all four directions  
- Installation of NB deceleration and acceleration lane

## 3. Civil Design Scope

Comments based on:  civil design drawings # R1-456-402 (May 26, 2003)  
and/or:  existing electrical drawings TE # \_\_\_\_\_

Crosswalk revisions required?

No  yes  All channelized right-turns to be “zebra markings”  
(description or attach drawing)

Stop lines revisions required?

No  yes  See attached dwg R1-456-402 (May 26, 2003)  
(description or attach drawing)

Lane marking revisions required?

No  yes  Continuity lines at NB deceleration and acceleration lanes  
(description or attach drawing)

Turning path revisions required?

No  yes  All movements designed to accommodate design vehicle WB-15  
(description or attach drawing)

Civil Design prepared by:

\_\_\_\_\_  
(Engineer's signature) A.B. Diamond (Diamond Engineering) July 15, 2003  
(print name) (date)

## 4. Traffic Design Scope

Road classification: \_\_\_\_\_ Urban Arterial  
(rural arterial, urban arterial, etc.)

Signing modifications required? (if yes describe in detail or attach drawing)

Guide Sign modifications required?

No  yes  Relocate existing post mounted G-1 (destination dirn) sign 50m south  
(size & location – stn.#)

Lane Use sign modifications required?

No  yes  Install shoulder mounted R-82R (this lane right) on EB & WB Cross St  
(location(s) – stn.#)

Turn restrictions sign modifications required?

No  yes  Install R-15L (no left) and R-15T (time restriction tab) on EB Cross St  
(type & location – stn.#)

Other sign modifications required?

No  yes  Remove W-7 (side road) warning sign in NB dirn, as access is being closed  
(description & location – stn.#)

# Traffic Engineering Checklist

Location: Hwy 25 @ Cross Street, District of North Peace

(route and cross street)

## 4. Traffic Design Scope (continued)

Special features revisions required? *(describe in detail if yes)*

Advance warning signs *(complete table below)*?

No  yes  Relocate existing NB advance warning flashing (AWF) sign \_\_\_\_\_  
(Which approaches?)

Approach	Speed km/h	Grade %	Approach	Speed km/h	Grade %
North	<b>60</b>	<b>- 4.2</b>	East	<b>50</b>	<b>0</b>
South	<b>60</b>	<b>2</b>	West	<b>50</b>	<b>0</b>
Road name: <b>Hwy 25</b>			Road name: <b>Cross Street</b>		

Island flashers:

No  yes  Install high intensity sheeting for W-54's- Intersection illuminated \_\_\_\_\_  
(Note those which exceed standards.)

Emergency preemption:

No  yes  City supplied "Sonic" pre-emption \_\_\_\_\_  
(Type – hardwire, audible, radio, strobe)

Indication lights: no  yes  Blue/white indicators on signal arms on N/S approaches \_\_\_\_\_  
(Type and location)

Rail preemption: *(which approaches?)*

No  yes  East approach \_\_\_\_\_

Blank-out display: no  yes  Fibre optic "no right turn" NB right \_\_\_\_\_  
(Type and approach)

Pedestrian Accommodation:

No  yes  N/S movement along Hwy 25 (audible cuckoo) – west side only (PA2) \_\_\_\_\_  
(Describe Location – Audibles, special pushbuttons, etc)

Cyclist Accommodation:

No  yes  Stencil markings on Cross St as per City's request \_\_\_\_\_  
(Describe Location– loops, stencils, pushbuttons)

Transit/HOV Requirements:

No  yes  Relocate bus bay to the downstream of the intersection in the NB direction \_\_\_\_\_  
(Describe – HOV laning, additional phasing)

Special detector requirements:

No  yes  NB/SB advance loops at AWF sign locations to extend A1 & A2 phases \_\_\_\_\_  
(Advance loops, queue loops, etc.)

Future requirements *(within 5 years):*

No  yes  Pre-wire for future WB left turn arrow \_\_\_\_\_  
(e.g. advance arrows, different phasing, etc.)

Controller requirements:

New  or Use existing  M cabinet  or S cabinet  Ministry supplied \_\_\_\_\_

Other items or comments: (Attach supplementary pages if the space provided is not adequate.)

- Signed and sealed civil drawings included

---



---



---



---



---

## 5. Signal Phasing - ATTACH a preliminary timing sheet showing the following:

- phase assignments
- advance warning times
- resting/recall phases
- Synchro Analysis reports

# Traffic Engineering Checklist

Location: Hwy 25 @ Cross Street, District of North Peace

(route and cross street)

## 5. Signal Phasing (continued)

Signal Phasing Layout (show all movements and north arrow).

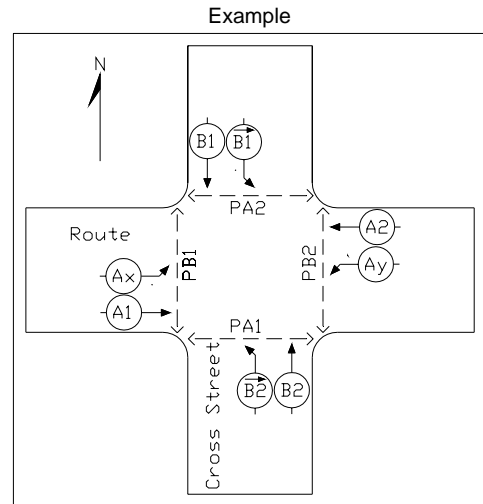
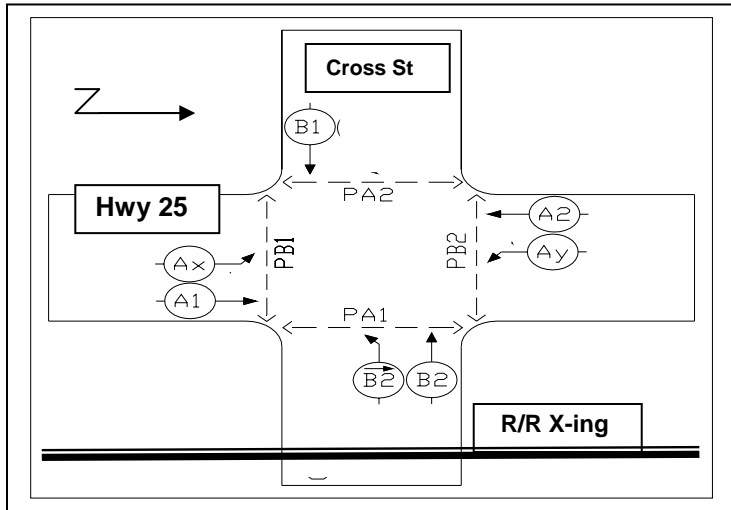

Signal Phasing Sequencing (relative to Signal Phasing Layout above).

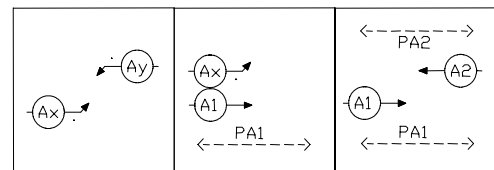
Show all combinations of vehicle and pedestrian movements in sequence.

Show emergency, railway, bus and other preemption sequences.

Identify clearance and preemption phases.

Traffic engineering prepared by:

\_\_\_\_\_  
(Engineer's signature)

Q.C. Surely (Quality Transportation)

(print name)

July 28, 2003

(date)

## 6. MoT Traffic Engineering Approval (Must be completed for a checklist prepared by a consultant)

- Recommend to proceed.
- Changes required (consultant must resubmit):**

\_\_\_\_\_  
\_\_\_\_\_  
\_\_\_\_\_

\_\_\_\_\_  
(MOT Traffic Engineer signature)

\_\_\_\_\_  
(print name)

\_\_\_\_\_  
(date)