



# TECHNICAL BULLETIN

Ministry of Transportation

ENGINEERING BRANCH  
TRAFFIC, ELECTRICAL, HIGHWAY SAFETY &  
GEOMETRIC STANDARDS SECTION  
BULLETIN NUMBER: **TE-2007-03**

|   |  |
|---|--|
| <b>Subject: Communication Conduit</b>   |  |
| <b>Date:</b> September 21, 2007   | <b>Author:</b> Brigid McGoran Canil, P. Eng. |
| <b>Bulletin Number:</b> TE-2007-03<br><b>Bulletin Type:</b> Requirement   | <b>Effective Date:</b> Immediately.          |
| <b>Audience</b>   | <b>Standards Affected</b>                    |
| Ministry Electrical Trades Supervisors and Managers; all holders of the Electrical and Traffic Engineering Manual; all Project Managers and Directors; all Design Consultants | Electrical and Traffic Engineering Manual    |

### BACKGROUND:

The Ministry of Transportation plans to expand the existing Regional Telecommunications Network (RTN) as detailed in the Regional Telecommunications Plan (2006). The Regional Telecommunications Network is the conduit and fibre-optic backbone that connects together the field devices, and Local Operations Centres to the Regional Transportation Management Centre (RTMC). The various field devices include advanced technologies such as cameras, Changeable Message Signs, and Weigh-in-Motion sites to improve the efficiency and safety of the multi-modal transportation network.

The Ministry currently has part of the Regional Telecommunications Network built, but needs to complete the missing links. It is most cost effective to install conduit as part of an existing construction project rather than later on its own.

### Policy:

Any roadwork that meets all the following criteria must include communications conduit for ITS purposes.

1. Any Provincial Numbered Roadway or Provincial Major Road Network, overpass, bridge or tunnel that does not already have communication conduit.
2. Any project that has an estimated construction cost of greater than \$250,000.
3. Any project within the GVRD limits, including Hwy 99 up to Whistler and Hwy 1 out to Chilliwack.

This does not include resurfacing and/or line painting only projects.

### Procedure:

Electrical Designers shall design the layout of 2 – 50 mm RPVC (Comm) for communication purposes and 1 – 50mm RPVC (COMM PWR) for communication power purposes for the entire length of the project. See attached sample drawings, (ESK-02 and ESK-03). Roadway crossings shall take place at each interchange and/or intersection, or each time the complete cross-section of the roadway is disturbed. The spacing of junction boxes and/or road crossings shall be a minimum of one crossing on any project.



# TECHNICAL BULLETIN

Ministry of Transportation

ENGINEERING BRANCH  
TRAFFIC, ELECTRICAL, HIGHWAY SAFETY &  
GEOMETRIC STANDARDS SECTION  
BULLETIN NUMBER: **TE-2007-03**

---

For major construction or rehab projects, where the complete surface of the roadway is disturbed, crossings shall take place each 600m.

For bridge and tunnel applications the electrical designers shall design the layout of 100 mm FRE with 3-32mm SDR11 HDPE inside. See attached sample drawing, (ESK-02 and ESK-03). The electrical designer shall provide a separate cost estimate to the project team.

Signal designs are expected to have communications conduit for the length of the project as well as at least one communications conduit crossing. Crossings are required when the complete width of the roadway is disturbed, or at each interchange and/ or intersection.

## **CONTACT:**

Brigid McGoran Canil, P.Eng.  
Manager, Telecommunications  
South Coast Region  
Phone: (604) 660-8062  
Email [Brigid.canil@gov.bc.ca](mailto:Brigid.canil@gov.bc.ca)

---

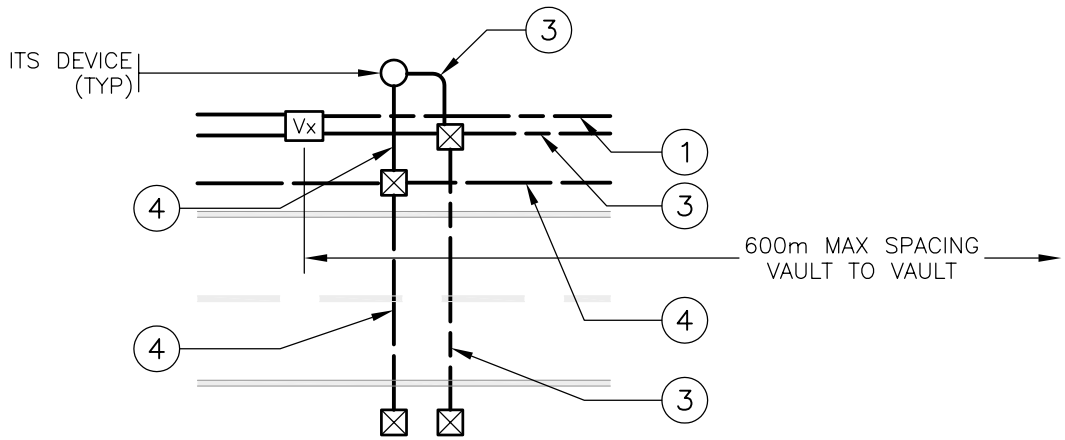

**DETAIL 1 TYP ROADWAY CROSSING**  
N.T.S.

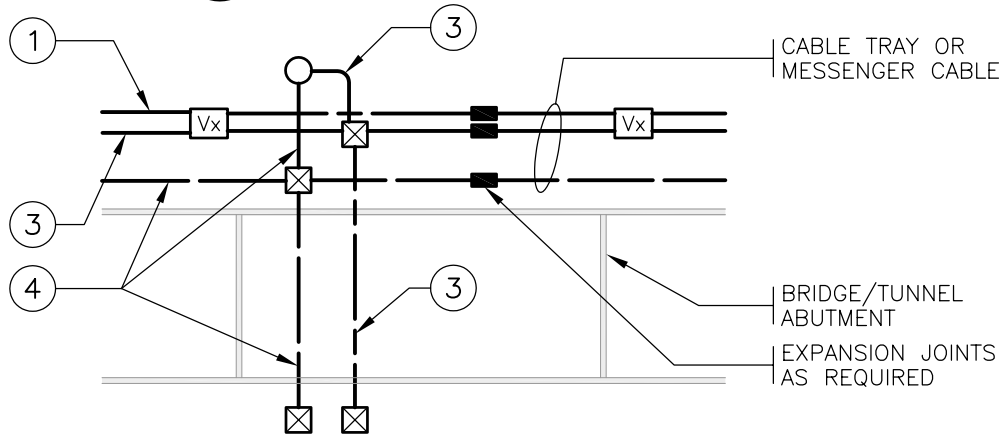

**DETAIL 2 TYP BRIDGE/TUNNEL CROSSING**  
N.T.S.

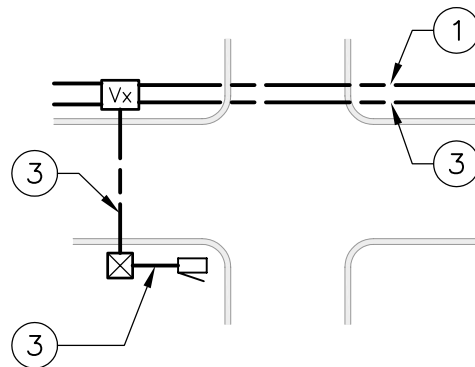

**DETAIL 3 TYP INTERSECTION**  
N.T.S. (INTERSECTION DUCTING NOT SHOWN)

| LEGEND |  |
|--------|--|
| ○      | ITS DEVICE   |
| ⊗      | MoT CONCRETE JB OR POWDER COATED ALUMINUM JB IN PARAPET                    |
| Vx     | A.E. CONCRETE 632 VAULT c/w GALVANIZED DOUBLE HINGE LID AND RACKING SYSTEM |
| ☐      | TRAFFIC CONTROLLER CABINET   |
| ⊗      | CONDUIT DESIGNATION (SEE CONDUIT SUMMARY TABLE ESK-03)                     |

| No. | Revision          | Date     |
|-----|-------------------|----------|
| F   |                   |          |
| E   |                   |          |
| D   |                   |          |
| C   |                   |          |
| B   | ISSUED FOR REVIEW | 07AUG08  |
| A   | ISSUED FOR REVIEW | 07JULY27 |

**PBA**  
CONSULTING ENGINEERS

*PBA Engineering Ltd.*  
4218 Commerce Circle  
Victoria, B.C. V8Z 6N6  
Tel 250.388.7222 Fax 250.388.7229

ITS TYPICAL CROSSING  
DETAILS

DRAWING No.  
**ESK-02**

# UNDERGROUND CIVIL NOTES

1. INDIVIDUAL CONDUITS SHALL ENTER AND EXIT CONCRETE VAULTS AND JUNCTION BOXES IN THE SAME POSITION AT EACH LOCATION FOR EASE OF IDENTIFICATION AND CONTINUITY.
2. SPACING BETWEEN POWER AND COMMUNICATION CONDUITS FOR LONGITUDINAL RUNS SHALL BE 300mm (UNLESS ENCASED IN CONCRETE). THE SPACING MAY BE REDUCED TO 50mm AT CROSSOVER POINTS WHERE THE CONDUITS ENTER AND EXIT JUNCTION BOXES AND PULL PITS.
3. CLEAR DRAIN ROCK.
4. ALL CONDUITS SHALL BE VERIFIED AND CLEANED USING THE FOLLOWING PROCEDURE:
  - TO VERIFY INTEGRITY OF CONDUIT, PULL THROUGH EACH DUCT, A HARD RUBBER MANDREL NOT LESS THAN 300mm LONG AND OF A DIAMETER 6mm LESS THAN INTERNAL DIAMETER OF DUCT, PRECEDED BY A SWAB OF SUITABLE DIAMETER TO REMOVE SAND, EARTH AND OTHER FOREIGN MATERIALS.
  - NOTIFY PROJECT ENGINEER IN THE EVENT OF CONDUIT FAILURE.
  - CLEAN DUCTS BEFORE LAYING. CAP ENDS OF DUCTS DURING CONSTRUCTION AND AFTER INSTALLATION TO PREVENT ENTRANCE OF FOREIGN MATERIALS.
  - INSTALL PULL LINE AND CAP ENDS OF DUCT USING RUBBER DUCT PLUGS.
  - TERMINATE CONDUIT ENDS IN THE JUNCTION BOX AS PER STANDARD DRAWINGS.
  - CLEAN AND VACUUM JUNCTION BOXES.
5. ALL CONDUIT PLUGS, TERMINATOR KITS, RPVC CONDUIT AND PULL ROPE, MUST BE MINISTRY PRE-APPROVED PRODUCT. REFER TO MINISTRY APPROVED SUPPLIER AND PRODUCT LIST FOR APPROVED PRODUCTS.
6. ALL DIMENSIONS ARE IN MILLIMETRES UNLESS OTHERWISE NOTED.
7. JUNCTION BOX SYMBOLS ARE NOT TO SCALE.
8. CONCRETE JUNCTION BOX AND VAULT LIDS SHALL BE LABELLED WITH 2" HIGH WELDED CHARACTERS AS FOLLOWS:  
 'COM' – COMMUNICATIONS (FIBRE AND COPPER)  
 '347/600V' – 347/600V VOLT POWER  
 '120/208V' – 120/208V VOLT POWER
9. ALL JUNCTION BOXES SHALL HAVE GALVANIZED STEEL LIDS UNLESS OTHERWISE NOTED.
10. ALL EQUIPMENT LOCATIONS SHALL BE LAID OUT BY THE CONTRACTOR AND REVIEWED BY THE ENGINEER PRIOR TO INSTALLATION.
11. INSTALL LEVEL AREA AROUND BASE AND JUNCTION BOXES. AJUST LEVEL AREA TO ACCOMMODATE JUNCTION BOXES.
12. RESTORE ALL SURFACES TO MATCH EXISTING.
13. ALL POLES SHALL HAVE A COMMUNICATION AND POWER CONDUIT RACEWAY.
14. CONCRETE JUNCTION BOXES AND VAULTS SHALL REST ON A 300mm DEEP LAYER OF 19mm

## CONDUIT SUMMARY TABLE

| No. | DESCRIPTION  | APPLICATION | NOTES  | INNER DUCT CONDUIT COLOR               |
|-----|--|-------------|--|--|
| ①   | 100mm PVC<br>3-32mm SDR11 HDPE<br>100mm PVC<br>3-32mm SDR11 HDPE | MoT COMM    | –<br>–   | BLUE, RED, ORANGE<br>BLUE, RED, ORANGE |
| ②   | 100mm FRE<br>3-32mm SDR11 HDPE<br>100mm FRE<br>3-32mm SDR11 HDPE | MoT COMM    | FRE FOR USE UNDER BRIDGE<br>FRE FOR USE UNDER BRIDGE | BLUE, RED, ORANGE<br>BLUE, RED, ORANGE |
| ③   | 2-50mm RPVC (COMM.)  | MoT COMM    | ITS CONDUIT  | –                                      |
| ④   | 1-50mm RPVC (PWR.)   | MoT PWR     | ITS CONDUIT  | –                                      |

P:\ACTIVE\PROJECTS\03050\_GATEWAY PROJECT OWNERS ENGINEER\DRAWINGS\DESIGN DRAWINGS\ESK-03; 27/07/2007 01:03 PM; JCURTIS

| No. | Revision          | Date     |
|-----|-------------------|----------|
| F   |                   |          |
| E   |                   |          |
| D   |                   |          |
| C   |                   |          |
| B   |                   |          |
| A   | ISSUED FOR REVIEW | 07JULY27 |



**PBA Engineering Ltd.**  
 4218 Commerce Circle  
 Victoria, B.C. V8Z 6N6  
 Tel 250.388.7222 Fax 250.388.7229

ITS TYPICAL CROSSING  
 NOTES AND TABLE

DRAWING No.  
**ESK-03**