



Subject: Interim Bicycle Guidelines for Traffic Signals	
Date: November 30, 2002	Author: Ross Casey, Senior Electrical Standards Technologist
Bulletin Number: TE-2002-07 Bulletin Type: Interim Guideline	Effective Date: Immediately.
Distribution	Standards Affected
Ministry Electrical Trades Supervisors and Managers; all holders of the Electrical and Traffic Engineering Manual.	Electrical and Traffic Engineering Manual

BACKGROUND:

The Ministry Cycling policy was officially implemented in February 2000. It requires that provision for cyclists be made on all new and upgraded provincial highways. All exceptions to this policy must be subject to an evaluation procedure as outlined in the Ministry Cycling Guide published in April 2000.

Policy:

The electrical designer shall ensure that provisions for cyclists are made on all new and upgraded traffic signal designs on designated cycling routes.

Procedure:

Prior to starting the traffic signal design, the designer shall:

1. Become familiar with the current revision of the Ministry Cycling Guide
2. Contact the appropriate Ministry Regional Traffic Engineer (RTE) or designate and the relevant municipality to a.) determine if there are any current cycling issues relating to the project location, b) identify the types of treatments currently used in the municipality and c) identify whether any of the roadways are designated cycling routes.
3. Contact the Electrical Engineering Centre and the RTE for technical direction for accommodating cyclists at the traffic signal based on the responses to the previous two items.

On designated cycling routes, the design **shall** incorporate features to accommodate cyclists as specified by the RTE, such as additional pushbuttons, curb-side pushbutton posts, vehicle or bicycle detector loops, pavement markings and/or signing.

On non-designated cycling routes, the design **should** consider the requirement for the same bicycle features and incorporate these features as specified by the RTE.

All exceptions to this policy must be evaluated and documented as per the Ministry Cycling Guide.

Only designs complying with these procedures will be approved.



TECHNICAL BULLETIN

Ministry of Transportation

ENGINEERING BRANCH
TRAFFIC, ELECTRICAL, HIGHWAY SAFETY &
GEOMETRIC STANDARDS SECTION
BULLETIN NUMBER: **TE-2002-07**

Sample drawing SK1 is attached, showing a bicycle pushbutton installation detail and a typical pavement marking/bicycle detection loop treatment.

CONTACT:

Ross Casey, Senior Electrical Standards Technologist
Traffic, Electrical, Highway Safety and Geometric Design Section
Engineering Branch
Phone: (250) 387-7688
Email ross.casey@gems8.gov.bc.ca

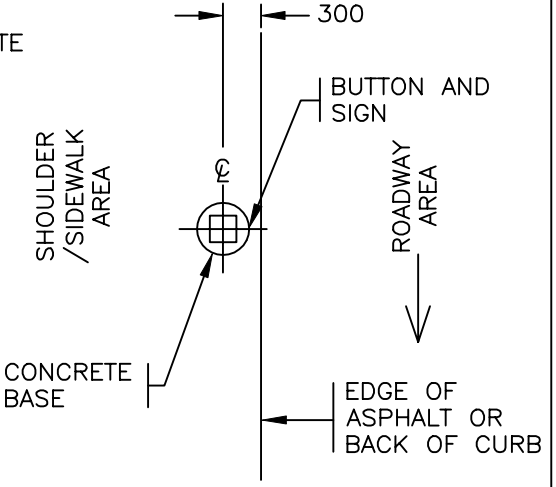
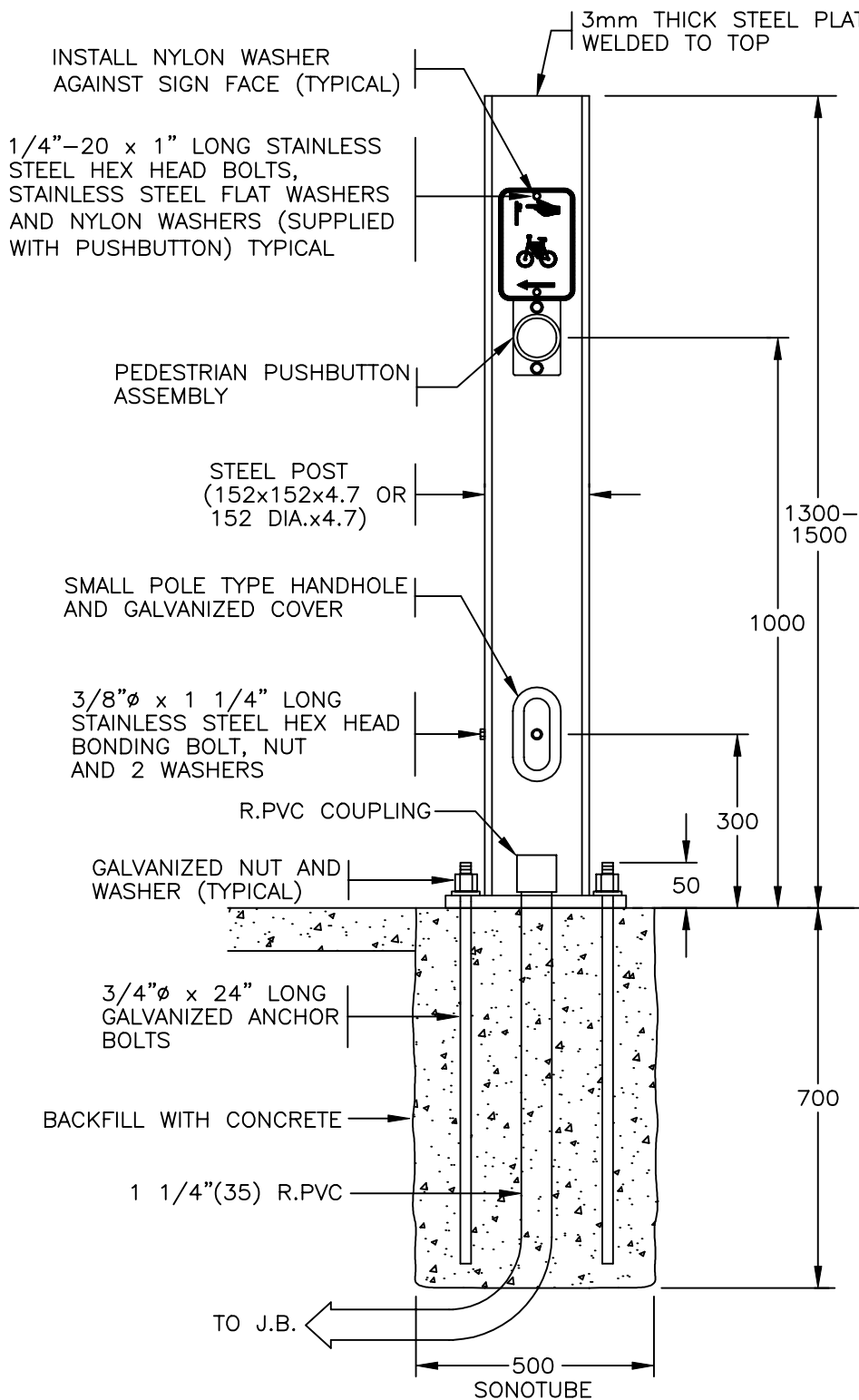

PLAN

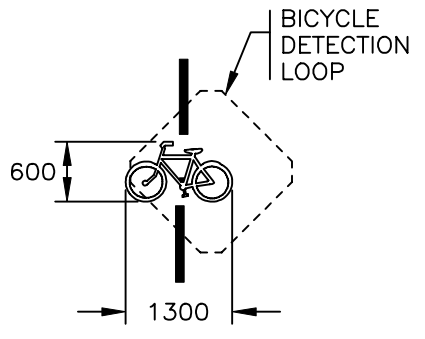

PAVEMENT MARKING (TYP.)

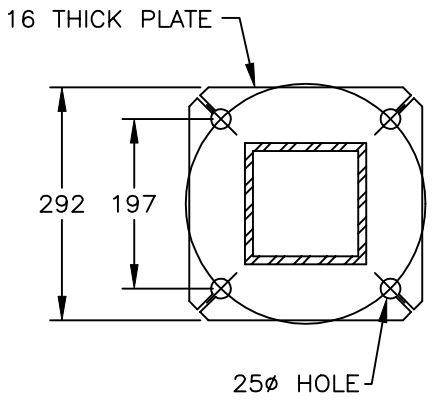

BASE PLATE

NOTES

1. SEE STANDARD SPECIFICATIONS & SPECIAL PROVISIONS FOR ADDITIONAL INFORMATION.
2. ALL DIMENSIONS ARE IN MILLIMETRES UNLESS OTHERWISE NOTED.
3. POST TO BE HOT DIP GALVANIZED AFTER FABRICATION.

NOT TO SCALE



No.	Revision	Date
F		
E		
D		
C		
B		
A		

**BICYCLE PUSHBUTTON POST
INSTALLATION DETAILS**

Date	Approved
SPECIFICATION DRAWING No. SK-1	