

Before You Start

1. Park with the wheels chocked, air system at full pressure and spring parking brakes released.
2. Find the adjusting bolt. Hexagonal bolts are near the middle of the slack adjuster and square bolts are at the bottom of the adjuster.

Adjusting Square Bolts

1. Find the 3/4 inch (1.90 cm) pawl hex cap.
2. Disengage the unit by prying up and holding the round button on the hex cap with a screwdriver. If the cap doesn't have a button, remove the hex cap, spring and pawl.
3. Turn the adjusting bolt **counterclockwise** until the lining contacts the drum.
4. Back off the bolt half a turn **clockwise**.
5. Release the hex cap button or reinstall the spring and pawl.
6. Recheck push rod travel.

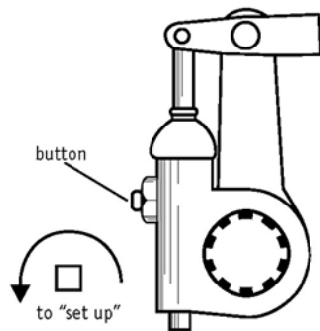

A slack adjuster with a square adjusting bolt. The adjuster has a clevis with two pins and an external linkage.

Adjusting Hexagonal Bolts

1. Turn the adjusting bolt clockwise until the lining contacts the drum.
2. Restore running clearance by turning back the adjusting bolt half a turn **counterclockwise**. Don't worry if you feel resistance or hear a ratcheting sound—it takes force to back off the bolt.
3. Recheck push rod travel.

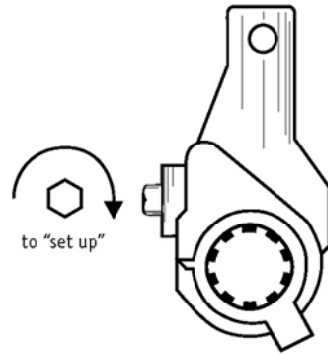

One type of slack adjuster with a hexagonal adjusting bolt. This brand has an anchor tab and a clevis with one pin.

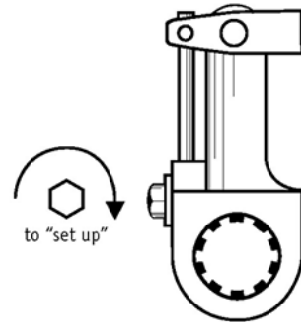

Another type of slack adjuster with a hexagonal adjusting bolt. This brand has a clevis with two pins and an external linkage.

The material in this brochure was adapted with permission from *Air Brakes from the Driver Seat II* © Allan C. Wright.

Important Numbers

British Columbia Ferry Corporation

24-Hour Recorded Information: 1-888-223-3779
Commercial Reservations: 1-888-223-3779

Canada Customs

General Information: (604) 666-0545 or 1-800-461-9999

Dangerous Goods

Transport Canada: (604) 666-2955
Spills, Provincial Emergency Line: 1-800-663-3456
B.C. Dangerous Goods: (250) 387-5585
Canadian Transport Emergency Centre:
Information (24 hours): (613) 992-4624
Emergency (24 hours): (613) 996-6666 (call collect)

Environment Canada

Information: (604) 664-9100

Forest Fire Reports

1-800-663-5555
Cellular Phones: *5555

Insurance Corporation of British Columbia (ICBC)

Commercial Vehicle Permit Line (Please use only when your local scale is closed.): 1-800-559-9688

Dial-A-Claim:

In Greater Vancouver, call: 520-8222
Outside Vancouver, call: 1-800-910-4222

Out of Province Claims:

In Greater Vancouver, call: 520-8800
Outside Vancouver, call: 1-800-667-7740

Other ICBC Numbers:

ICBC Prorate: (604) 443-4450 or 1-800-665-4336
Public Enquiries: 1-800-663-3051
ICBC TIPS Line: 1-800-661-6844

Provincial Emergency Program

24-Hour Emergency: 1-800-663-3456

Road Conditions (B.C.)

Vancouver Callers: (604) 299-9000, enter 7623
Other Callers: 1-900-565-4997 (toll call)
Cellular Phones: *4997

Tourism

B.C. Tourism: 1-800-663-6000

Weather

British Columbia: (604) 299-9000, enter 3500

Note: the 1-800 and 1-888 numbers listed above are toll-free in B.C.

www.icbc.com



PI221 (042001)

Within an Inch of Your Life

A professional driver's guide to checking and adjusting air brakes.



Within an Inch of Your Life

The most common cause of brake failure is poor brake adjustment. The popular type 30 air chamber has 2½ inches (6.35 cm) of available stroke. A correctly adjusted brake has only ½ inch (1.27 cm) of slack, leaving 2 inches (5.08 cm) of reserve chamber stroke. When slack reaches 1 inch (2.54 cm) the brakes **must** be adjusted. *This is the most important inch of your life.*

It's the Law

Provincial regulations require drivers to check manual and automatic slack adjusters daily, during the pre-trip inspection. It's up to you, the professional driver, to ensure your vehicle has safe, properly adjusted brakes.

You're also required by law to check your brakes before driving down steep grades that are posted with regulatory signs.



A brake check regulatory sign.

Simple Physics

When you brake lightly, even poorly adjusted brakes seem to work. But under moderate to heavy braking, you could find yourself in a runaway truck. Some sobering facts:

- At an 80 PSI application, a brake chamber with 1 inch of slack (2.54 cm) strokes 1¾ inches (4.45 cm) because of component stretch. This reduces reserve chamber stroke to ¾ inch (1.91 cm).
- Cast iron expands when heated. On a hot brake drum, this can cause the push rod to stroke a further ½ inch (1.27 cm), reducing reserve stroke to ¼ inch (.64 cm).
- Brake lining wears rapidly at high temperatures. If the lining wears down just the thickness of three sheets of paper, the push rod strokes a further ¼ inch (.64 cm). This could cause the chamber to bottom out and your brakes to fail.

Don't Overestimate — Check the Slack!

Manual Slack Adjusters

Checking Manual Adjusters

1. Pull the push rod out to its limit using your hands or a short pry bar.
2. Measure the distance the push rod travels (the "slack"). If the slack is 1 inch (2.54 cm) or more, you **must** adjust the brakes.

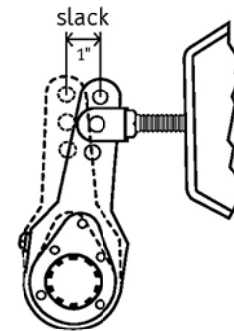

A manual slack adjuster.

Adjusting Manual Adjusters

1. Turn the adjusting bolt until you feel solid resistance.

NOTE: Some adjusting bolts turn clockwise and some turn counterclockwise. If you're turning the bolt the right way, the cam will turn in the same direction as it does when you apply the brakes. Watch the chamber push rod and slack adjuster arm. If you detect outward movement, you're turning the bolt the wrong way.

2. Back off the bolt one-quarter to one-half a turn to restore running clearance.
3. Recheck push rod travel.

Automatic Slack Adjusters

Automatic slack adjusters are designed to self-adjust, but sometimes they fail or are incorrectly installed. You must check them during pre-trip inspections and at brake checks.

Checking Automatic Adjusters

1. Make an 80 to 90 PSI application. If your truck doesn't have an application pressure gauge, turn off the engine, pump reservoir pressure down to between 90 and 100 PSI, and then fully apply the brakes.
2. Check the stroke. If it meets or exceeds the length specified in the table below, make an emergency adjustment and take the vehicle to a service depot.

Chamber Type	Stroke Must Be Less Than	
	Inches	Centimetres
20	1 ¾	4.45
24	1 ¾	4.45
24 LS*	2	5.08
30	2	5.08
30 LS*	2	5.08

*LS (long stroke) chambers have square-shaped inlet ports or a tag on a clamp bolt. Consult manufacturer's data if your chamber type isn't listed here.

Adjusting Automatic Adjusters

Warning: Adjust automatic slack adjusters only as an **emergency measure**, so that you can get the vehicle to a service depot. Repeated manual adjustments will wear down the slack adjuster's internal components, which could lead to brake failure.