

Ministry of Transportation



Project 31445 - Yahk Weigh Scale, Highway 3/95
Updated Business Case for Property Acquisition and Construction

UPDATED DRAFT REPORT



May 2004
Project 82002-004

This report was prepared by ND LEA Consultants Ltd. (ND LEA) for the BC Ministry of Transportation. The disclosure of any information contained in this report is the sole responsibility of the client. The material in this report reflects ND LEA's best judgement in light of the information available to it at the time of preparation. Any use of which a third party makes of this report, or any reliance on or decisions to be made based on it, are the responsibility of such third parties. ND LEA accepts no responsibility for damages, if any, suffered by a third party as a result of decisions made or actions based on this report.

NDLEA™

ND LEA Consultants Ltd.
236 St. Paul Street
Kamloops, BC V2C 6G4
(250) 828-1511
www.ndlea.com

Table of Contents

1. Introduction.....	1
1.1. BACKGROUND.....	1
1.2. PROJECT STATUS	2
1.3. VALUE ENGINEERING	2
2. Problem Definition.....	3
2.1. PERFORMANCE ASSESSMENT	3
2.1.1. <i>Traffic Volumes</i>	3
2.1.2. <i>Origins and Destinations</i>	4
2.1.3 <i>Highway Classification</i>	5
2.1.4 <i>Mobility</i>	5
2.1.5 <i>Safety</i>	6
2.2. PAVEMENT	8
2.3. RELIABILITY	8
2.4. PROBLEM SUMMARY	8
3. Option Evaluation.....	10
3.1. RECOMMENDED OPTION	10
3.2. MULTIPLE ACCOUNT EVALUATION.....	12
3.2.1 <i>Evaluation Criteria</i>	12
3.2.2 <i>Preferred Option Evaluation Results</i>	14
3.2.3 <i>Multiple Account Evaluation Summary</i>	17
3.3. KINGSGATE BORDER CROSSING OPERATION	18
3.4. SENSITIVITY.....	19
3.5. ALTERNATIVES	20
4. Implementation	22
4.1. TIMING AND STAGING.....	22
4.2. COORDINATION WITH OTHER PROJECTS AND PROGRAMS	22
4.3. TECHNICAL RISKS.....	23
5. Conclusions.....	24

Executive Summary

ES.1 Introduction

In April 2000, the Kootenay Region of the Ministry of Transportation and Highways completed a business case to advance proposed improvements to the Yahk Weigh Scale and the Highway 3/95 Junction to property acquisition and construction. The project was not constructed at that time, and since then the project has been the subject of a Value Engineering review and subsequent revisions to the original design. An update to the business case was completed in October 2003.

ES.2 Problem Definition

The Yahk weigh scale is strategically placed to capture north/south truck traffic using the Kingsgate border crossing and east/west movements along Crowsnest Highway 3. Although general traffic growth has slowed from a compound growth rate of 3.5% rate annually in the 1980s to less than 1.0% in the last 10 years, truck traffic has increased substantially and now represents over 20% of the traffic. Over 50% of the trucks using the scale are also using the Kingsgate border crossing.

Several documents have identified problems at this location, including the Crowsnest Highway No. 3 Corridor Study, Highway 3 Corridor Management Plan and the March 2000 Business Case. The identified problems involved congestion at the weigh scale and spill-over of weigh scale traffic onto the highway. The identified problems are summarized as follows:

- **Mobility** – The mobility problem is related to traffic operations and the lack of adequate truck storage for trucks on the scale site. A simulation has indicated that the maximum number of vehicles that need to be accommodated during a peak hour scale volume of 40 trucks is seven; two greater than the current available space. If trucks arrive in a group during this same period, the number of trucks spilling back onto the highway could be even greater. Based on the simulation, capacity to handle at least 8 trucks (combined in-processing and waiting to be processed) should be provided to minimize the potential for spill-over onto the highway and thus disruption to highway flow.
- **Safety** – The collision rate and severity are considerably higher than the provincial averages for similar facilities. Congestion and conflicting traffic movements resulting from weigh scale truck traffic, tourist traffic accessing local amenities, the intersection of highways, an unusually high proportion of truck traffic and, high driver workload in a rural environment, are all contributing factors to the high accident rate. With the exception of the intersection of Highway 3/95 none of the other access points is controlled. Because the area is rural in nature and sparsely populated, most of the traffic is commercial and tourist orientated, and thus may be unfamiliar with the area. The large open space with no channelization or definition is confusing and can result in unexpected vehicle movements.

No reliability problems, with the exception of blockages due to scale traffic spillover at the Highway 3/95 junction, have been identified. Significant rutting at the Highway 3/95 junction and pavement deterioration at the scale entrances have been noted.

The problems at the scale are affecting the efficiency of the border crossing. While there is no direct effect on operation, the delays at the scale affect the ability of traffic to reach the crossing.

ES.3 Option Evaluation

The recommended option indicates a new single access to the weigh scale combined with the existing Highway 3/95 intersection. Improvements will include highway channelization, intersection improvements, weigh scale site improvements and access management. The recommended option is illustrated in Figure ES.1

Figure ES.1: Recommended Option

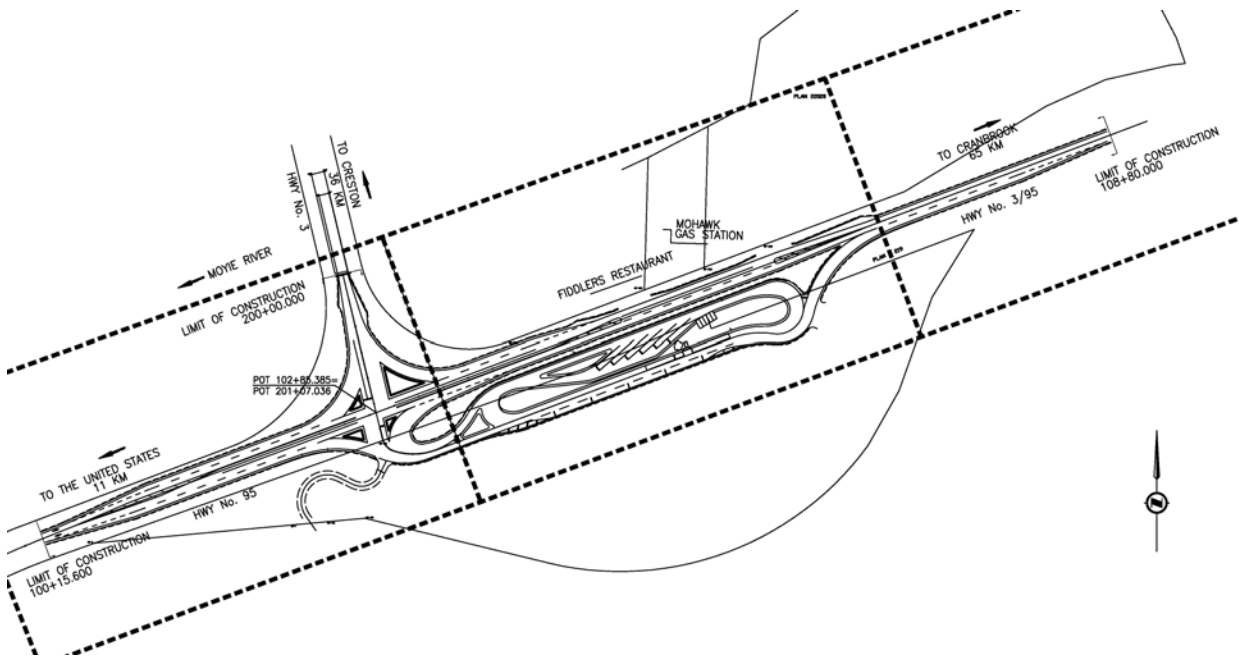

The estimated cost of this option is \$2.425 M. The updated costs include the recommendations of the Value Engineering workshop.

Table ES.1 provides a summary of the Multiple Account Evaluation. The discounted cost of \$2.041 M does not include past expenditures as these costs apply equally to the base case and preferred option.

Table ES.1: MAE Summary

Account	Preferred Option
Financial	
Project Cost	\$2,425
Discounted Costs	
Project Cost	\$2,041
Salvage Value	\$369
Increased Maintenance and Rehab. Cost	-\$26
Life Cycle Cost	\$1,646
Customer Service	
Reduced Travel Time Cost	\$4,522
Reduced Vehicle Operating Cost	\$1,750
Reduced Accident Cost	\$2,236
Total User Benefits	\$8,508
Accident Reduction (%)	25%
Community / Social	
Full Property Takings	0
Partial Property Takings	1
Special Property Considerations	0
Overall Community Displacement Rating	None
Community Severance	Negligible
Equity	No Effect
Economic	
Net Present Value	\$6,862
Benefit-Cost Ratio	5.2
NPV Project Cost Ratio	3.5
Regional Economy	Minor - Positive
Support of Highway Economic Role	Supportive
Benefit Due to Reduced Out-of-Pocket Expenses	\$5,200
Environmental	
Environmental Sensitivities	Awaiting CEAA Screening
Reduction in CO Emissions (25-years)	237,000 kg

Note: All dollar amounts in thousands of dollars

The benefit-cost assessment shows very strong benefits associated with the project. Given the importance of efficient operation of the scale to cross-border travel, a second benefit-cost assessment was conducted that considered only the benefits accrued by traffic using the Kingsgate-Eastport border crossing. This assessment continues to show a strong benefit-cost ratio of 2.1.

Notwithstanding the current low cattle truck volumes, the Yahk scale site does not have sufficient capacity to service truck traffic needs. In addition, the accident rate on the highway adjacent to the scale site is considerably above the provincial average for similar highways.

The proposed project provides an opportunity to improve both the scale capacity and safety issues on the highway.

ES.4 Implementation

Project implementation is anticipated to take place over two years, with engineering and environmental studies to be completed in 2004 and construction in 2005. Some costs have already been incurred prior to 2003. Given the scope of the project, there is little opportunity to phase the project differently.

As a result to changes in the Provincial Government organizational structure, the Ministry of Transportation has become responsible for weigh scale infrastructure. As such, the previously identified cost share with ICBC now falls within the jurisdiction of the Ministry. As this project combines pavement rehabilitation, intersection improvements and scale site expansion, the opportunities for combining projects and programs have been maximized.

ES.5 Conclusion

The estimated mobility benefits generated by eliminating the situation where trucks waiting to access the scale are blocking traffic on the highway are significant. Even without these benefits being considered, the total benefits of the project are considerably higher than the costs. When only the benefits attributable to cross-border travel are considered, the benefits remain higher than costs.

A value engineering review has been completed and the recommendations incorporated. Based on the degree of previous work completed, there does not appear to be further reasonable opportunities to modify the project, nor is there any benefit in further delay.

It is recommended that this project be advanced to property acquisition and construction.

1. Introduction

In April 2000, the Kootenay Region of the Ministry of Transportation and Highways completed a business case to advance proposed improvements to the Yahk Weigh Scale and the Highway 3/95 Junction to property acquisition and construction. The project was not constructed at that time, and since then the project has been the subject of a Value Engineering review and subsequent revisions to the original design. An update to the business case was completed in October 2003.

This report is a compilation and update of the previous work. Much of the original business case has been included within this report in an attempt to provide a full business case within a single document.

1.1. Background

Crowsnest Highway 3 is a primary arterial route running east-west along the southern boundary of the province. The project is located at the junction of Highways 3 and 95, west of the community of Yahk as shown in Figure 1.1.

Figure 1.1: Study Area



Highway 3/95 links British Columbia to the State of Idaho at the Kingsgate border crossing and to Alberta via Highway 3. Kingsgate is the only full-service commercial permitting port in the Kootenays. The value of cargo transiting this route exceeds \$3 billion annually. At present, Highway 3/95 is the primary route for fruit and vegetables from California growers to markets in Alberta. It is also a main haul route for cattle shipments from Alberta to the United States.

The Kingsgate border crossing is the busiest of all crossings in the Kootenays and accounts for 40% of all truck crossings between the United States and the Kootenay region. The Yahk weigh scale is the first commercial vehicle inspection facility for northbound cross-border traffic and thus the operation of the scale and border crossing are linked.

Highway 3/95 is a north/south route of international significance. It is presently classified as a Rural Secondary Highway¹, and could be considered for Rural Primary² classification as it is an international and interprovincial trade route.

1.2. Project Status

Improvements to the weigh scale were first identified as a project in 1995 and estimated to cost approximately \$500,000. Lighting and signing improvements increased this to \$800,000. The planning and evaluation (P&E) phase of the project was approved for advancement to design and engineering (D&E) in April 1999.

During the design and engineering phase the scope increased. A business case to advance the project from D&E to property acquisition and construction was submitted March 2000. This business case identified and evaluated several options with the objective “to improve the flow of truck traffic to and from the accesses to the Yahk weigh scale, and to improve the flow of traffic at the intersection of Highway 3 and Highway 95”. Improvements to the intersection also provide the benefit of improved cross-border travel at the Kingsgate border crossing.

1.3. Value Engineering

In February 2003 a Value Engineering (VE) review was undertaken was to review the detailed design drawings. The purpose of the review was designed to determine and recommend value enhancements to the project.

The VE team identified a number of potential modifications. Some of the proposals involved significant scope alternatives that may be beneficial, but beyond current needs. The implementation of some of these concepts could be considered at a later date.

The recommendations of the Value Engineering review resulted in marginal cost savings based upon the updated cost estimate.

1 Strategic Highway Classification – derived from the British Columbia Highway Classification Study, Section 4.1(b)

2 Windermere to Radium Hot Springs Study – Preliminary Planning Investigation

2. Problem Definition

A clear definition of the problem helps to clarify the need for improvements. In addition to identifying problems, the performance assessment sets the baseline against which improvement options can be measured. For this project, the primary beneficiaries are highway users – commercial vehicles and general traffic. Therefore, the performance improvements represent the benefits of the project.

2.1. Performance Assessment

2.1.1. Traffic Volumes

The Yahk weigh scale is strategically placed to capture north/south truck traffic using the Kingsgate border crossing and east/west movements along Crowsnest Highway 3, including a high percentage of trucks. Although truck percentages vary through the year, volumes are reasonably consistent. In September 1999 a vehicle composition count was conducted in the Yahk area. Those results showed daily average truck volumes of:

- 589 trucks/day – Highway 3/95, north of Yahk;
- 319 trucks/day – Highway 95, south of Yahk; and
- 336 trucks/day – Highway 3, west of Yahk.

Although general traffic growth has slowed from a compound growth rate of 3.5% rate annually in the 1980s to less than 1.0% in the last 10 years, truck traffic has increased substantially and now represents over 20% of the traffic. Figure 2.1 shows AADT volumes and growth between 1992 and 2001 at count station P-35-1, 2.4 km east of the Moyie River Bridge in Yahk. The figure also shows the southbound truck volumes at the Kingsgate border crossing.

Scale staff have indicated that volumes through the scale are in the range of 500 to 600 trucks/day in the summer. Peak days are mid-week and the highest hourly volumes occur between mid-morning and mid-afternoon. When cattle trucks are running, peak hour truck volumes are in the order of 40 trucks per hour. Using a straight-line trend, the 2028 volume is estimated to be 3068 veh/day, north of Yahk. Assuming the proportion of truck traffic remains at 22%, the future truck volume (2028) is estimated to be 45 trucks/hr.

Figure 2.1 Total Traffic Historic Growth 1992 – 2001
Permanent Count Station P-35-1 (2.4 km East of the Moyie River Bridge) and Southbound Trucks, Kingsgate Border Crossing

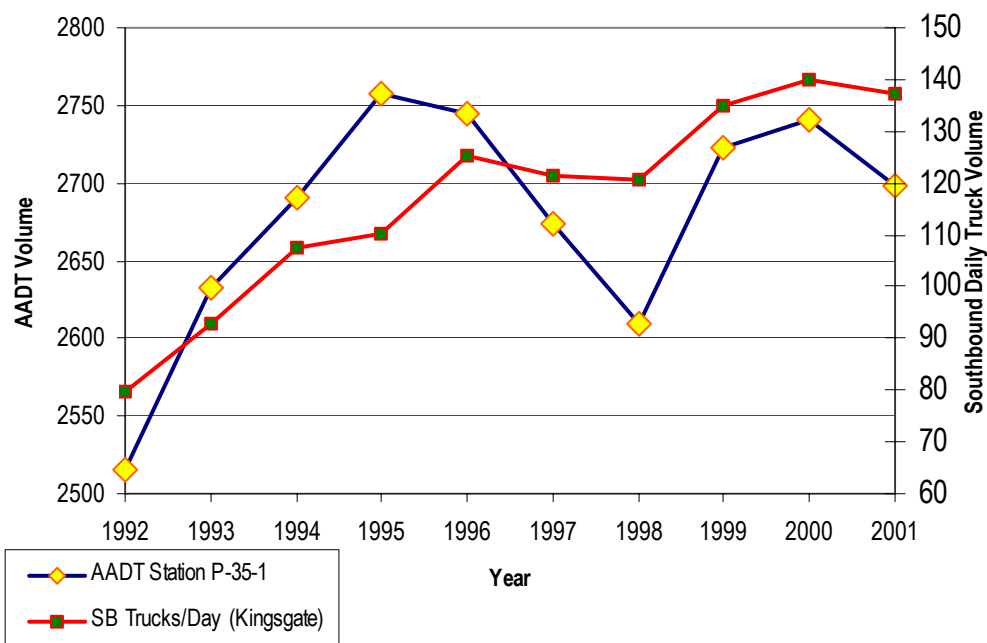

A simulation of current scale conditions was conducted based on an hourly volume of 40 trucks per hour with an average processing time of 1.5 minutes. Based on this simulation, there will be an average of 3 trucks in the scale area at one time and a maximum of 7 trucks. Given that there is room for 5 trucks on the scale site (1 in processing, 4 in queue), spill over onto the highway would occur in the peak hours. This is consistent with observations of scale staff.

The simulation was run again with the future truck volume of 45 trucks/hr. The average number of trucks increases to 4 and the maximum to 8.

Although no serious accident or injury has been directly attributed to weigh scale traffic to date, weigh scale staff observing day-to-day operations have indicated that “near-misses” are common. When “gridlock” situations occur, scale staff perform flagging and traffic control on the highway, directing trucks, recreational vehicles and general traffic along highway shoulders and through private accesses and property to clear the congestion. This is not an acceptable long-term solution.

2.1.2. Origins and Destinations

Truck origin-destination surveys were conducted at the Kingsgate border crossing in February and August 2001. Table 2.1 provides a summary of the results.

Table 2.1: Kingsgate Border Crossing, Truck Origin-Destination, 2001

Origins	Destination								Total
	Western United States	Southern United States	Eastern United States	Eastern BC	AB, SK, MB	Eastern Canada	BC - West of Yahk	Unknown	
Western United States	0.3%	0.0%	0.0%	7.6%	38.1%	0.6%	0.9%	0.3%	47.7%
Southern United States	0.0%	0.0%	0.0%	0.0%	0.3%	0.0%	0.0%	0.0%	0.3%
Eastern United States	0.0%	0.0%	0.0%	0.0%	0.0%	0.0%	0.0%	0.0%	0.0%
Eastern BC	6.1%	0.0%	0.3%	0.3%	0.0%	0.0%	0.0%	0.0%	6.7%
AB, SK, MB	32.3%	0.0%	0.3%	0.0%	0.0%	0.0%	0.0%	0.9%	33.4%
Eastern Canada	0.6%	0.0%	0.0%	0.0%	0.0%	0.0%	0.0%	0.0%	0.6%
BC - West of Yahk	0.3%	0.0%	0.0%	0.0%	0.6%	0.0%	0.0%	0.0%	0.9%
Unknown	0.0%	0.0%	0.0%	0.6%	1.2%	0.0%	0.0%	8.7%	10.5%
Total	39.5%	0.0%	0.6%	8.4%	40.1%	0.6%	0.9%	9.9%	100.0%

As the table shows, only a very small proportion of the trucks crossing the border travel to/from the west on Highway 3. It is interesting to note that some truck traffic with an origin in BC, west of Yahk had other Canadian destinations. These trucks had origins in Vancouver and destinations in the prairie provinces. The reason for travel through the United States rather than through Canada is unknown.

Virtually all of the cross-border truck traffic currently passes through the scale.

Assuming that all of the traffic on Highway 95 south of Yahk is cross-border traffic, over half of the traffic through the scale is cross-border traffic, again demonstrating the strong link between the scale and border operations.

2.1.3 Highway Classification

The highway is a two-lane rural highway with a rural arterial service class, and secondary highway strategic class. The intersection is stop controlled by with a flashing warning light.

2.1.4 Mobility

Travel speed was determined in the original 2000 business case using the Photolog over a four-year period between 1993 and 1996. The estimated average travel speed was 63 km/h. Observed speeds were similar to average travel speeds calculated from the Photolog, thus no adjustment to Photolog speeds was made. Since there has been no significant change in volumes since 1996, these average travel speeds are still applicable. Table 2.2 summarizes these average travel speeds.

Table 2.2: Travel Speed Summary

Year	1993 _W	1994 _E	1995 _W	1996 _E	Avg.
Speed (km/h)	83.1	45.5	71.3	53.3	63.3

W – Westbound E - Eastbound

The posted speed in the vicinity of the weigh scale is 50 km/h. The original 2000 business case did not provide an explanation for the higher westbound speeds. However, westbound vehicles are in a transition from an 80 km/h posted speed zone. Eastbound traffic would have just passed through the Highway 3/95 Junction, and thus would be still accelerating away from the junction.

2.1.5 Safety

Accident history information for the Highway 3/95 junction, also known as the Curzon Junction, was extracted from the Ministry's Highway Accident System (HAS) to determine safety performance, the assessment included Segments 1375, 1380 and 2105 as follows:

- Segment 1375 - 200 metres west on Highway 3;
- Segment 2105 - 200 metres south on Highway 95; and
- Segment 1380 - 600 metres north on Highway 3/95.

The original business case submission included data from 1987 to 1997, and compared it with province wide data from 1993 to 1995. Because of inconsistencies in police reporting procedures for this updated assessment, data from 1996 to 2000 has been used and compared with provincial averages for approximately the same period.

The reported collision frequency within the study area from 1996 to 2000 is summarized by severity class in Table 2.3.

Table 2.3 Collision Frequency, 1996 to 2000

Segment	Fatal	Injury	PDO*	Total
1375	0	6	2	8
1380	0	4	3	7
2105	0	0	0	0
Total	0	10	5	15

* Property Damage Only

Figure 2.2 shows a summary of the first contributing factors for 1996 to 2000. As the figure shows, the most common first contributing factor is weather. The original business case submission considered data from 1987 to 1997, which indicated that over half the collisions involved animals. The more recent collision records do not indicate that this trend is

Figure 2.2: Casual Factors

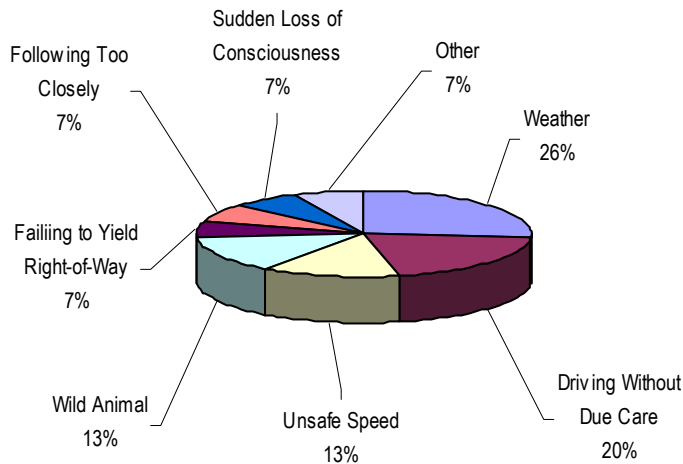

continuing. However, this conclusion should be used with caution, as the more recent data does not include many of the PDO collisions. Animal related collisions are often PDO.

Based on the 1996 to 2000 reported collisions, about half of the collisions were due to environmental and other factors such as weather, animals and loss of consciousness. The remainder are all potentially related to driver behaviour and risk taking due to frustration. Even the weather and animal related collisions could be

partially attributed to high risk taking and other driver behaviour. Collisions caused by frustration and driver-related risk taking are often mitigable with improvements to address the factors that create the frustration. High risk taking behaviour is often associated with inadequate roadway capacity or geometrics.

The primary measure of safety performance is a comparison of historical observed collision rates with provincial averages for similar facilities. The original business case submission reported a collision rate of 6.58 collisions/MVK. However, this rate is based on reported collisions using a wide range of collision reporting criteria.

Using the 1996 to 2000 data, the observed collision rate was 3.25 collisions/MVK for all collisions and 1.63 collisions/MVK for fatal/injury collisions. These rates are considerably higher than the provincial average of 0.45 collisions/MVK for all severity classes and 0.24 collisions/MVK for fatal and injury collisions. The provincial average rates are based on two-lane rural arterial highways with AADT volumes less than 5,000 vehicles per day.

The critical rates for the study area are 1.10 collisions/MVK for all collisions and 0.74 collisions/MVK for fatal and injury collisions. Since the observed collision rate is greater than the critical rate, the observed rate is greater than the provincial average with 95% confidence.

2.2. Pavement



The pavement condition rating (PCR) is the commonly used by the Ministry as a measure of highway condition. The PCR is a combination of the Pavement Distress Index and the Riding Comfort Index. A PCR value greater than 7.0 indicates generally good condition and that resurfacing is not required. PCR values for 2000 indicate that pavement throughout the study area is in generally good condition. However, as the photo indicates, the pavement on the travel lanes appears to be in good condition, but is not as good on the highway edge of the scale entrance.

Based on the original business case submission, pavement condition adjacent to the weigh scale has deteriorated faster than the overall corridor pavement condition due to:

- truck traffic looping through the weigh scale results in double the truck traffic volumes over the segment of Highway 93/95 adjacent to the scale;
- pavement shearing from sharp turning trucks; and
- frequent stopping and acceleration of trucks.

While the pavement immediately adjacent to the current scale entrance is generally good, according to MOT district staff, rutting is significant at Curzon Junction, particularly on the Highway 3 eastbound approach.

2.3. Reliability

There are no official recorded closures of Highway 3/95 in the immediate area of the Yahk weigh scale. However, anecdotal accounts and field observations exist of traffic stoppages due to highway congestion. These are operational in nature and are related to mobility.

2.4. Problem Summary

Several documents have identified problems at this location, including the Crowsnest Highway No. 3 Corridor Study, Highway 3 Corridor Management Plan and the March 2000 Business Case. The identified problems involved congestion at the weigh scale and spill-over of weigh scale traffic onto the highway. The identified problems are summarized as follows:

- **Mobility** – The mobility problem is related to traffic operations and the lack of adequate truck storage for trucks on the scale site. A simulation has indicated that the maximum number of vehicles that need to be accommodated during a peak hour of 40 trucks is seven; two greater than the current available space. If trucks arrive in a group during this same period, the number of trucks spilling back onto the highway could be even greater. Based on the simulation, capacity to handle at least 8 trucks (combined in-processing and waiting to be processed) should be provided to minimize the potential for spill-over onto the highway and thus disruption to highway flow.
- **Safety** – The collision rate and severity are considerably higher than the provincial averages for similar facilities. Congestion and conflicting traffic movements resulting from weigh scale truck traffic, tourist traffic accessing local amenities, the intersection of highways, an unusually high proportion of truck traffic and, high driver workload in a rural environment, are all contributing factors to the high accident rate. With the exception of the intersection of Highway 3/95 none of the other access points is controlled. Because the area is rural in nature and sparsely populated, most of the traffic is commercial and tourist orientated, and thus may be unfamiliar with the area. The large open space with no channelization or definition is confusing and can result in unexpected vehicle movements.

No reliability or infrastructure problems have been identified.

3. Option Evaluation

This section provides a summary of the potential options to address the deficiencies associated with the weigh scale and Highway 3/95 junction.

3.1. Recommended Option

The recommended option indicates a new single access to the weigh scale combined with the existing Highway 3/95 intersection. Improvements will include highway channelization, intersection improvements, weigh scale site improvements and access management. The recommended option is illustrated in Figure 3.1

Figure 3.1: Recommended Option

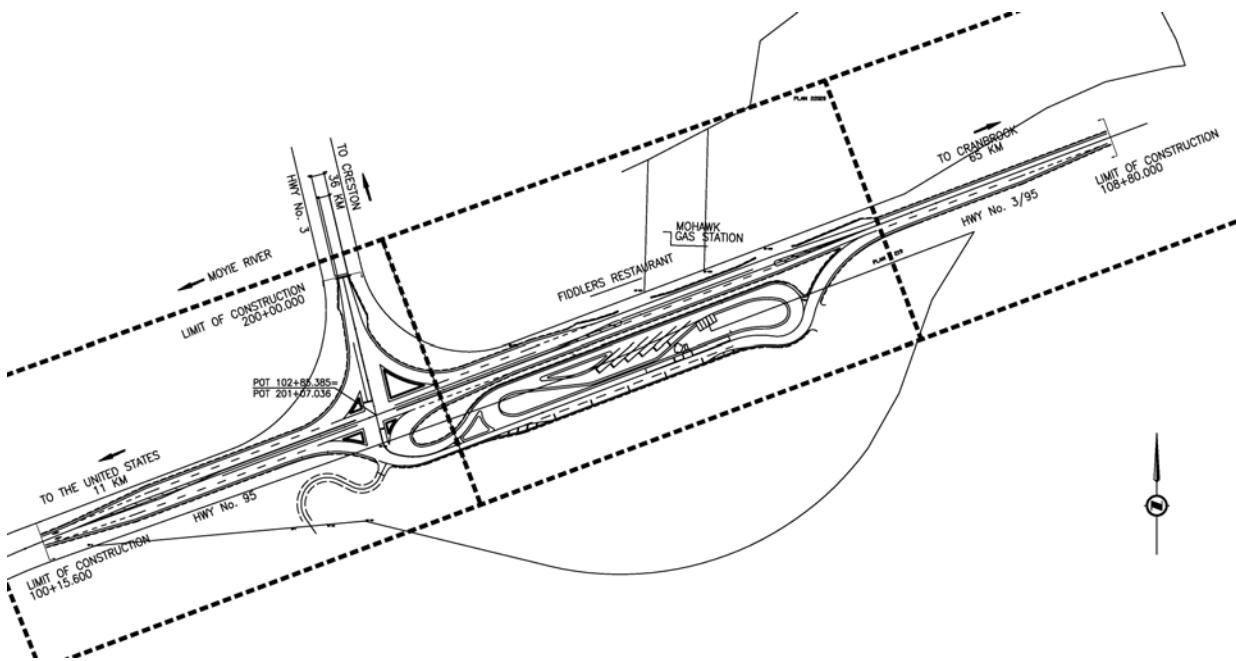

The improvements provide additional space to accommodate weigh scale site improvements, increased parking/inspection space, improved turning movement and a northbound acceleration lane for weigh scale traffic.

The option addresses the identified concerns of all stakeholders. Discussions with weigh scale staff indicate that they support the option as it addresses their concerns of lack of inspection parking, minimizes inspection leakage (trucks bypassing the scale) and improves safety. The Ministry and public concerns related to highway performance (mobility and safety) are addressed. The highway commercial area adjacent to the weigh scale will receive increased exposure and improved access. The reduction in delays at this location will help to improve overall cross-border travel.

Table 3.1: Updated Cost Estimate

Past Expenditures	\$142,234
2003-2004 Allocation	\$175,000
2004-2005 Allocation	\$2,107,766
Total Project Budget	\$2,425,000

The estimated cost of this option is \$2.425 M. The updated costs include the recommendations of the Value Engineering workshop. The costs are summarized in Table 3.1

A review of the Value Engineering team findings and recommendations compare well with the original concept design (Option7A). The main proposals supported by the VE team are summarised in Table 3.2.

Table 3.2: Value Engineering Review Recommendations Summary

Value Engineering Proposal	Value
1. Review the bulb design opposite the Highway 3/95 intersection into the weigh scale.	\$20,000 increase
2. Review wheel path and pavement widths. Check turning movements to confirm they will accommodate larger truck movements.	\$25,000 decrease
5. Review access treatment to commercial area.	Cost neutral.
7. Review functionality of laning on east side of scale platform. Through lane, parking lane and weighing platform lane.	\$5,000 decrease
8. Review need for provisions of an out-of-service area for weigh scale.	Not costed, however costs anticipated to be minimal as site is already available and little works would be required
9. Review the connection of the logging road to the weigh scale site.	\$4,000 increase
12. Review need to have separate left turn and through lanes on the Creston approach to the intersection.	\$2,200 decrease
19. Review truck parking layout in the weigh scale inspection area.	Cost neutral.
27. Review typical sections regarding side slopes and need of 100mm AC on shoulders vs. 50mm AC on shoulders.	Not costed, however, there should be a small reduction in costs.
29. Review drainage between highway and scale site. Open vs. closed drainage, ditch grades, etc.	\$30,000 decrease Option "A" Cost neutral Option "B"
31. Review the benefits of providing the northbound right out from the scale site.	Cost neutral.
33. Review the need for the right turn acceleration lane for the Creston the Kingsgate movement.	\$13,000 decrease
34. Review other construction delivery methods.	Cost neutral.
36. Review design to ensure future pavement rutting will be minimized.	Not costed.

3.2. Multiple Account Evaluation

Multiple account evaluation (MAE) is the method most commonly used by the Ministry of Transportation to comparatively evaluate options.

There are five accounts that are usually considered by the Ministry:

- Financial;
- Customer Service;
- Social / Community;
- Economic Development; and
- Environmental.

3.2.1 Evaluation Criteria

The evaluation criteria for each account are described in the following sections.

.1 Financial Account

The financial account represents the discounted life-cycle cost of the project. It includes all project costs (construction, property, engineering, project management), rehabilitation costs over the life of the analysis period, annual maintenance and salvage value, discounted over 25 years at 6%.

The financial account does not include consideration of cost-sharing or other differentiation between who pays. Cost-sharing should be considered exclusive of the MAE process and has been addressed in Section 4.1. Costs are based on MicroBencost default values (May 2003 defaults for B.C.). Annual maintenance costs are estimated to be \$3,967 per lane kilometre based on the 2002-2003 provincial maintenance contract costs.

.2 Customer Service Account

The customer service account is the cost to highway users expressed as dollar values for travel time, vehicle operating costs and accidents. The MicroBencost default travel time values of \$11.17/hour for automobiles, \$20.90/hour for single unit trucks and \$23.41/hour for combination trucks have been used. The vehicle operating costs are based on a combination of costs for fuel, oil, tires, depreciation and maintenance. The default MicroBencost values were used as the basis for accident costs. The default value for fatal accidents is approximately \$5.7 M, for injury accidents is \$100,000 and property damage only collisions carry a value of approximately \$7,300.

All user costs are discounted over the 25-year analysis period at 6%.

.3 Social / Community Account

The social / community account assesses the potential effect of the highway project on communities and social values. Factors generally considered include:

- Noise, Visual and Pollution Impacts – exposure and magnitude of the impacts related to the highway project;
- Community Displacement – property takings, partial and full;
- Community Severance – the “barrier effect” of the highway on local vehicle and pedestrian traffic;
- Consistency With Community Plans – degree of support the project provides to local community plans; and
- Equity – changes that benefit one group at the expense of another.

.4 Economic Account

This account provides an indication of **provincial** economic benefits. Regional and local benefits are generally captured within the community / social account. Also, income and jobs generated during highway construction represent an economic benefit to the local area, but are a loss to other regions and thus there is no net provincial gain. The provincial economic benefits are derived from reductions in out-of-pocket costs for transportation and health care due to reduced travel times, lower vehicle operating costs and reduced highway accident costs. Out-of-pocket cost savings are calculated as follows:

Total Travel Time Savings x (% trucks x truck value of time) / (% autos x auto value of time) + 35% of accident savings + 100% of vehicle operating cost savings

The economic benefit is then estimated by applying an economic multiplier of 1.68 to the out-of-pocket cost savings. The multiplier is based on an average for various industries from the provincial input-output model. This indicator provides only a rough indication of the benefits and should be used with caution.

.5 Environmental

While this account generally identifies significant environmental issues, it is not a replacement for an environmental assessment. Where reliable information is available, the account should identify consumption of lands with specific environmental or other value, such as parks/protected areas, wetlands, agricultural lands and high habitat values. The account may also include fuel consumption and carbon monoxide emissions as calculated within MicroBencost.

3.2.2 Preferred Option Evaluation Results

The full multiple account evaluation has been completed for the base case – or do minimal option - and the preferred option described previously. Other alternatives have previously been assessed and have not been further evaluated within this business case.

.6 Base Case

The base case assumes no changes to the existing configuration. This would mean that existing collision rates will continue into the future, and that the spill-over onto the highway of trucks waiting at the scale will become more frequent as volumes increase.

The only costs that have been included in the base case costs are resurfacing and annual maintenance. The resurfacing costs are assumed to be \$50,000/lane-kilometre, for 2.0 lane-kilometres. Resurfacing is assumed to take place every 15 years, with the next resurfacing in 2006, and subsequently in 2021. Annual maintenance costs are estimated to be \$7,934 for the study area.

Currently, mobility is good except when trucks waiting for the scale queue onto the highway and block other traffic. Using the simulation, and assuming 22% trucks, the estimated relationship between total hourly volume and the amount of time traffic is blocked due to waiting trucks is summarized in Table 3.3. This table also shows the assumed delay as a result of the blockage. Only one lane will be blocked when trucks back-up onto the highway, and other vehicles will be able to pass in the opposing lane. It has been assumed that the average travel speed drops from 50 km/h to 25 km/h. For every delayed vehicle, the extra travel time is 144 seconds. Using the proportion of the hour that is blocked, the delay was assigned among the hourly volume to derive an average delay per vehicle. The additional travel times are consistent with observed delays when the highway has been blocked in the past.

Table 3.3: Estimated Delays Due to Trucks Blocking the Highway

Hourly Volume – All Vehicles (Veh/hr)	Proportion of Hour Blocked	Estimated Average Delay per Vehicle (sec)
0	0	
160	8.3%	12
180	16.7%	24
200	41.7%	60
225	83.3%	120

As indicated in the performance assessment section, current collision rates are:

- Fatal + Injury 1.63 collisions/MVK
- PDO 1.62 collisions/MVK

Using the relative proportions of fatal and injury collisions based on the provincial averages, the specific rates for fatal and injury collisions are:

- Fatal 0.093 collisions/MVK
- Injury 1.54 collisions/MVK

.7 Financial Account

Based upon the design review, cost estimate update and Value Engineering session, the updated total project budget is now \$2.425 M. The past expenditures are approximately \$142,000. These costs are not recoverable and are therefore applicable to the base case and improved case.

.8 Customer Service Account

Improved operational performance of traffic movement through the weigh scale facility will result in increased inspection volumes and efficiencies that will further impact highway safety and operation.

These improved efficiencies will have direct and indirect highway performance impacts. Direct impacts to the highway as a result of weigh scale truck traffic queuing onto the highway will be minimized as the scales ability to accommodate all truck traffic on site is improved. Indirect impacts will be achieved through improved inspections and enforcement with the additional scale capacity.

The mobility benefits will be related to the virtual elimination of scale queues backing up onto the highway. There may also be some mobility improvement with the reduction in accesses and improved delineation of the remaining accesses. However, this improvement will be relatively small and difficult to quantify. Therefore the mobility benefits have been calculated based on a reduction in the average delay per vehicle attributable to truck queuing on the highway as identified in Table 3.3. The travel time benefits were calculated using MicroBencost and the current defaults. The delays due to trucks queued onto the highway were applied within MicroBencost as intersection delays. For the improved case, these delays were removed. The overall travel time savings are estimated to be \$4.5 M over 25 years.

There will be some reduction in vehicle operating costs because of the more uniform flow through the study area and reduction in stop-and-go traffic, particularly when trucks overflow onto the highway. The discounted vehicle operating savings are \$1.8 M over 25 years.

The safety benefits will be due to a combination of the addition of left turn lanes and reduction in the access density. While there will be safety benefits associated with the increased on-site capacity of the scale and the removal of queued vehicles from the highway, no collision reduction factors are readily available and based on discussions with scale staff, there have been no serious accidents as a result. Therefore no reduction factor has been applied specifically for that improvement. The literature review of safety effects of intersection design elements³

³ *Safety Effects of Left- and Right- Turn Lanes. Federal Highway Administration, 2002(FHWA-RD-02-089)*

conducted by the Federal Highway Administration indicated that collision reduction with the addition of a left-turn lane on a rural two-lane highway was in the order of 22%. The access consolidation and delineation is assumed to generate a reduction in collision rate of 0.07 collisions/MVK for each access removed. The access consolidation is equivalent to a reduction of approximately 2 accesses. This reduction of 0.14 collisions/MVK represents a collision reduction of approximately 4%. The total collision reduction used for the assessment is 25% ($0.78 \times 0.96 = 0.75$). The reduction was applied equally among all severity classes. The discounted safety benefit over 25 years is \$2.2 M.

The total user benefits are approximately \$8.5 M. It should be noted that both the 2000 and 2003 business case submissions had considerably lower benefits. While the safety benefits were comparable, this assessment indicates considerably higher mobility benefits because the effect of highway blockages were considered.

.9 Community / Social Account

The overall community effects of the project will be positive. While some accesses are to be consolidated, there is no loss of business access to the highway and the improvements include provision of dedicated left turn accesses to the businesses off the highway. The left turn lanes, combined with the improved access delineation should create a net positive effect for the adjacent businesses. The additional on-site capacity of the scale will allow waiting trucks to move off the highway, thus reducing noise and visual intrusion effects from in front of these businesses. No displacement or severance effects are anticipated.

.10 Economic Account

Highway 3 forms part of the National Highway System and forms an integral part of the east/west connectivity between British Columbia and rest of Canada. Immediately south of the weigh scale, Highway 3/95 links British Columbia to the State of Idaho at the Kingsgate Border Crossing. Kingsgate is the only full-service commercial border crossing in the Kootenays. The value of cargo transiting this route exceeds \$3 billion annually.

The State of Idaho projects a 30% to 50% increase in truck traffic upon completion of proposed upgrades from American federal highway initiatives for highway infrastructure improvements between Coeur d'Alene and the Eastport/Kingsgate border crossing.

Given the importance of this route, improvements that address congestion concerns will have a positive indirect economic benefit. There are indirect economic benefits associated with the ability for better enforcement of maximum loads. The improved weigh scale site will reduce the number of trucks bypassing the site, resulting in better enforcement and thus compliance. This has a net indirect benefit of reduced rehabilitation costs and less wear and tear on vehicles since surfaces last longer. The indirect costs are difficult to quantify.

The provincial economic benefits resulting from reduced out-of-pocket expenses are estimated to be in the order of \$5.2 M.

.11 Environmental Account

No environmental issues have arisen through the course of the previous assessments. A CEAA screening report will be completed and any environmental effects will be identified through the screening.

3.2.3 Multiple Account Evaluation Summary

Table 3.4 provides a summary of the Multiple Account Evaluation. The discounted cost of \$2.041 M does not include the sunk costs as these cost apply equally to the base case and preferred option.

Table 3.4: MAE Summary

Account	Preferred Option
Financial	
Project Cost	\$2,425
Discounted Costs	
Project Cost	\$2,041
Salvage Value	\$369
Increased Maintenance and Rehab. Cost	-\$26
Life Cycle Cost	\$1,646
Customer Service	
Reduced Travel Time Cost	\$4,522
Reduced Vehicle Operating Cost	\$1,750
Reduced Accident Cost	\$2,236
Total User Benefits	\$8,508
Accident Reduction (%)	25%
Community / Social	
Full Property Takings	0
Partial Property Takings	1
Special Property Considerations	0
Overall Community Displacement Rating	None
Community Severance	Negligible
Equity	No Effect
Economic	
Net Present Value	\$6,862
Benefit-Cost Ratio	5.2
NPV Project Cost Ratio	3.5
Regional Economy	Minor - Positive
Support of Highway Economic Role	Supportive
Benefit Due to Reduced Out-of-Pocket Expenses	\$5,200
Environmental	
Environmental Sensitivities	Awaiting CEAA Screening
Reduction in CO Emissions (25-years)	237,000 kg

Note: All dollar amounts in thousands of dollars

3.3. Kingsgate Border Crossing Operation

As previously indicated, there is a strong link between the operation of the scale at Yahk and the Kingsgate border crossing. Delays incurred at the Yahk Weigh Scale are incurred by all cross-border truck traffic, and delays due to blockage of the highway at the scale are incurred by all cross-border traffic.

Approximately 53% of all truck traffic and 35% of all passenger car traffic passing the scale are also crossing the border. Therefore, the travel time, vehicle operating and safety benefits accrued by the proposed improvements at the weigh scale will also be accrued by the cross border traffic.

The benefit-cost assessment was run again to determine the benefits that can be directly attributed to cross-border traffic. The results of this assessment are shown in Table 3.5.

Table 3.5: Benefit-Cost Assessment for Benefits Accrued to Border Crossing Traffic Only

Financial Account	
Project Cost	\$2,425
Discounted Costs	
Project Cost	\$2,041
Salvage Value	\$369
Increased Maintenance and Rehab. Cost	-\$26
Life Cycle Cost	\$1,646
Customer Service Account	
Reduced Travel Time Cost	\$1,764
Reduced Vehicle Operating Cost	\$746
Reduced Accident Cost	\$896
Total User Benefits	\$3,406
Economic Indicators	
Net Present Value	\$1,760
Benefit-Cost Ratio	2.1
NPV Project Cost Ratio	1.4

Note: All dollar values in thousands of dollars

Even when only the benefits accrued to traffic using the Kingsgate/Eastport border crossing are considered, the economic indicators remain very strong. This is partly due to the very strong benefits associated with the project, but is also an indicator of the high proportion of traffic, particularly trucks, passing the scale while travelling to or from United States.

There are other potential, but less direct, effects of the scale improvements on border operation. With additional on-site storage for trucks at the scale site, it may be possible to hold trucks at the scale when southbound border operation is slow. This is unlikely to be effective as truck drivers will not want to risk losing their place in the queue at Kingsgate. Another possibility may be to install a web camera at the border, which can be viewed at the scale, or to simply provide border waiting estimates at the scale. Southbound trucks could then be either held at

the scale or diverted to an alternate crossing location as appropriate if delays are excessive. This would only be effective for particularly long waits due to the backtracking required with other crossing locations, but may help to address the worst situations. In the longer term, there may be some ability to provide facilities for southbound truck to electronically submit manifest data for cargo shipments from the Yahk scale location in advance of arriving at the border. Again, the improved on-site conditions at the scale would help to permit these types of service to be introduced. There may be other potential border pre-screening that could take place at the scale to help reduce congestion at border. This would not replace any of the current inspections at the border, but there may be potential to help speed up operation at the US entry. Specific options would need to be developed in conjunction with scale staff, US Department of Homeland Security, Canada Customs and Revenue Agency and the Canadian Food Inspection Agency.

3.4. Sensitivity

An analysis was conducted to test the sensitivity of the following:

- Discount Rate (4%, 8%, 10%);
- Cost Estimate (50% and 150% of the estimate);
- Collision Reduction Rate (20% and 30%); and
- Traffic Growth Rate (164% of 2003 volumes in 2028 and no growth).

The results are summarized in Table 3.6.

As the results show, the net present value remains positive in all scenarios. The strongest benefits are derived from mobility, generated based on the removal of trucks queuing onto the highway. The estimated performance drop associated with this queuing is substantial. While not formally included in the sensitivity analysis, it is useful consider the effect of the mobility benefits being lower given the uncertainty associated with the mobility benefit estimate. The mobility benefits are estimated to be approximately \$4.5 M. If no mobility benefits were considered, the net present value would remain positive at over \$2 M, and would be positive in all of the sensitivity tests summarized in Table 3.6.

Table 3.6: Sensitivity Analysis

Discount Rate	6%	4%	8%	10%
Discounted Cost	\$2,041	\$2,117	\$1,969	\$1,901
Salvage Value	\$369	\$606	\$227	\$141
Increased Maint/Rehab	-\$26	-\$15	-\$33	-\$38
Life Cycle Cost	\$1,646	\$1,496	\$1,709	\$1,722
User Benefits	\$8,508	\$10,642	\$6,946	\$5,779
Net Present Value	\$6,862	\$9,146	\$5,237	\$4,057
Benefit Cost Ratio	5.2	7.1	4.1	3.4
Cost Estimate	50%		150%	
Project Cost	\$1,141		\$3,424	
Discounted Project Cost	\$1,020		\$3,061	
Life Cycle Cost	\$810		\$2,482	
User Benefits	\$8,508		\$8,508	
Net Present Value	\$7,698		\$6,026	
Benefit Cost Ratio	10.5		3.4	
Collision Reduction Rate	25%	20%	30%	
Life Cycle Cost	\$1,646	\$1,646	\$1,646	
Safety Benefits	\$2,236	\$2,657	\$1,770	
User Benefits	\$8,508	\$8,929	\$8,042	
Net Present Value	\$6,862	\$7,283	\$6,396	
Benefit Cost Ratio	5.2	5.4	4.9	
Traffic Growth Rate	111%	164%	0%	
Life Cycle Cost	\$1,646	\$1,646	\$1,646	
User Benefits	\$8,508	\$12,258	\$8,078	
Net Present Value	\$6,862	\$10,612	\$6,432	
Benefit Cost Ratio	5.2	7.4	4.9	

3.5. Alternatives

There were seven options considered in the Planning and Evaluation (P&E) phase of the project.

The following is a brief description of options considered. Options 7.1 to 7.7 below are variations of the preferred option (Option 7) described in the planning and evaluation report. Options 7.1 to 7.3 were screened from further evaluation due to operational and performance concerns. Options 7.4 to 7.6 were assessed further, but were not fully evaluated as they did not address the performance and operational issues. Option 7.7 best addressed all issues and was advanced to design and engineering and Value Engineering.

The following provides a brief summary of the other options considered (all options numbers reference the planning and evaluation study):

- **Option 7.1 - Do nothing:** This demonstrate economic and highway performance. Regardless of economic analysis outcomes, this option does not address the operational concern and identified problems. Also the current site was not designed to accommodate modern long wheel base trucks and existing volumes. Do nothing was not considered for further evaluation, but represents the base case in this business case submission.
- **Option 7.2 - Remove or relocate the Yahk Weigh Scale:** The Yahk Weigh Scale is in a strategic location to regulate truck traffic from east/west Provincial and National sources, and north/south international traffic between the USA and Canada and therefore is necessary. This option was not considered for further evaluation.
- **Option 7.3 - Amend the Motor Vehicle Act so that trucks no longer must report to the weigh scales for inspection:** As the weigh scales provide the Ministry with an integral service in protecting public investment in highway infrastructure, the Ministry would not support such an amendment. This option was not considered for further evaluation.
- **Option 7.4 - Highway channelization:** This was considered as a option that would provide designated turning lanes for traffic accessing the weigh scales at the existing location. Initially this was considered as a effective low cost solution. Further examination found that the proposed turn lane may have to be 200-300 meters long to accommodate all trucks during high volumes. This would result in blocking access to the highway commercial area for northbound traffic and the highway would still be used for truck parking. The option did not address the lack of parking and capacity of the weigh scale, as well as the associated highway performance deficiencies.
- **Option 7.5 - Option 4 + weigh scale site improvements.** This option included highway channelization at the existing access and on-site improvements at the weigh scale to address the capacity concerns. There was insufficient space available to accommodate truck turning radii and improved inspection/parking while maintaining the access at its existing location.
- **Option 7.6 - Option 6 included; Option 5 (channelization, weigh scale site improvements) and access management:** Although this option addressed the minor impacts of the adjacent highway commercial area, it did not address the lack of available space for required improvements to the weigh scale and highway channelization.

The recommended option described in Section 3.1 was selected as the preferred among those described above.

4. Implementation

This section outlines the implementation issues associated with the project.

4.1. Timing and Staging

Project implementation is anticipated to take place over two years, with engineering and environmental studies to be completed in 2004 and construction in 2005. Some costs have already been incurred prior to 2003. The timing of all project costs is summarized in Table 4.1.

Table 4.1: Expenditure Schedule

Business Function	Prior Cost	Forecast FY 2004	Forecast FY 2005
Engineer	\$120,695	\$108,278	\$5,000
Project Management	\$21,539	\$5,000	\$60,000
Property		\$25,000	
Environmental		\$11,722	\$30,000
Supervision			\$225,000
Utility Moves			\$25,000
Materials			\$80,000
Contract QA			\$20,000
Construct Contract			\$1,512,766
10% Contract Contingency		\$25,000	\$150,000
Total	\$142,234	\$175,000	\$2,107,766

Given the scope of the project, there is little opportunity to phase the project differently. The reconfiguration of the scale site is directly tied to the proposed intersection improvements and access delineation. Completion of one component without the other would likely result in significantly higher costs as the Highway 3/95 junction would need to be constructed twice. It should be noted that the prior costs were not included in the discounted project costs indicated in the benefit-cost assessment.

Construction staging can also be achieved relatively easily since the project involves expansion of the existing roadway. Much of the construction will take place on the scale site, off the highway. The on-highway work can be completed with only minor disruption to traffic.

An assessment of the optimal timing (i.e., the year at which the NPV begins to decline) indicates that the optimal timing for the project has passed.

4.2. Coordination With Other Projects and Programs

As a result of changes in the Provincial Government organizational structure, the Ministry of Transportation has become responsible for weigh scale infrastructure. As such, the previously identified cost share with ICBC now falls within the jurisdiction of the Ministry. As this project

combines pavement rehabilitation, intersection improvements and scale site expansion, the opportunities for combining projects and programs have been maximized.

As Highway 3 is part of the National Highway System, and Highway 95 is a strategic international trade route, there is potential for cost-sharing with the federal government under the Strategic Highway Infrastructure Program (SHIP). Cost-share parameters need to be confirmed, but the Ministry has estimated that the cost share contribution would be approximately \$875,000, applied to construction in the 2005 fiscal year.

4.3. Technical Risks

Given the terrain and the level of work that has been completed at this location to date, the technical risks are minimal. There are no local utilities and land use growth is expected to be minimal in the area. There are risks associated with benefits being over-estimated, particularly related to mobility. The mobility benefits were mostly derived from the provision of additional capacity on the scale site. The future conditions were based on an assumption that truck traffic through the scale will continue to grow at historical rates. Currently, due to the ban on Canadian cattle into the United States, truck traffic at the scale is well below historical levels. This type of ban, or other factors that result in a change in cross-border traffic will have a significant effect on the volume of truck traffic at the scale. While current volumes are down, this is not a probable long-term trend. The risk associated with variable truck traffic is relatively small.

The current weigh scale site is considered to be an optional location for this corridor. Weigh Scale program staff have indicated that the current scale, once the proposed improvements are implemented, will meet needs for at least 15 to 20 years. Weigh-in-motion is not under consideration for this site, therefore no other significant improvements are expected at this location beyond those included in this project. Risks associated with a reduced life of the weigh scale or changes in the scale program are minimal.

There are no risks associated with property or business loss. In fact as noted in the MAE, the net property effect may be positive. Since there are no significant watercourses or other potentially environmentally sensitive areas, and since most of the project area has been previously disturbed, the potential for encountering environmental concerns is minimal.

5. Conclusions

Notwithstanding the current low cattle truck volumes, the Yahk scale site does not have sufficient capacity to service truck traffic needs. In addition, the accident rate on the highway adjacent to the scale site is considerably above the provincial average for similar highways. The proposed project provides an opportunity to improve both the scale capacity and safety issues on the highway.

The estimated mobility benefits generated by eliminating the situation where trucks waiting to access the scale are blocking traffic on the highway are significant. Even without these benefits being considered, the total benefits of the project are considerably higher than the costs. Overall, the benefits to the province and Canada associated with the improvements at the weigh scale are:

- total highway user cost savings of \$8.5 M;
- improved efficiency of cross-border travel;
- reduced inspection “leakage” and thus improved enforcement; and
- better access to the adjacent commercial area.

A value engineering review has been completed and the recommendations incorporated. Based on the degree of previous work completed, there does not appear to be further reasonable opportunity to modify the project, nor is there any benefit in further delay.

It is recommended that this project be advanced to property acquisition and construction.